

VAD-10003 PILOT'S OPERATING HANDBOOK



RV-12iS



THIS PAGE INTENTIONALLY LEFT BLANK



VAD-10003 PILOT'S OPERATING HANDBOOK



Airplane Serial Number: _____

Airplane Registration Number: _____

Date of Issue: _____
(See Form: 8130-15, Block 4)

Publication No.: DOC 13 POH

REVISION SUMMARY

This manual has been prepared in accordance with consensus standard ASTM F 2746. The RV-12iS has been shown to comply with consensus standard ASTM F 2245. The airplane must be maintained in accordance with consensus standard ASTM F 2295, Standard Practice for Continued Operational Safety Monitoring of a Light Sport Aircraft. Please note that this standard describes the responsibilities of the Owner/Operator.

Whenever revisions are issued, they must be inserted in the appropriate place in the manual. A black vertical line along the outside margin of the page will identify revised text and illustrations. Changes in spelling, punctuation and formatting will not be marked.

To verify the latest revision of the POH compare the rev level found on the cover page with the latest revision posted on the RV-12iS Service Information page of the Van's Aircraft web site.

Rev	Section	Change	Date
0	All	Initial Release	05/03/18
1	All	Initial Review	07/03/18
2	All	Publication	10/22/18
3	1.2	Updated values to match the changes made to Table 5.7.1	11/15/18
	3.7.6	Editorial Changes	
	5.7.1	The column for range was based on endurance. In the "912 iS Cruise Performance Notes" added the statement "... with recommended prop pitch."	
4	1.2	Range of 912 iS powered aircraft updated to not account for take-off, climb, or descent.	03/04/19
	5.7.1	Cruise Performance (912 iS) table updated to make iS and ULS directly comparable.	
	5.7.2	Cruise Performance (912 ULS) updated to make iS and ULS directly comparable.	
	7.4	Figure 7-5 updated to show TO/GA button.	
5	2.8	Changed fuel limitations Minimum was 39.2, Caution Range was 39.2 to 40.6, Normal Range was 40.6 to 50.8	11/08/19
	3.5.3	Title of section was Engine Air Restart	
	3.5.3.1	Added "Spar Pin Override Switch – HOLD DOWN"	
	3.5.3.2	Added "Spar Pin Override Switch – HOLD DOWN"	
	4.4	Remove EFIS – POWER UP before the master switch was turned on. Added "Fuses – CHECK"	
	Continued on next page		

REVISION SUMMARY (CONTINUED)

Rev	Section	Change	Date
5	4.7	“ Lane Fault Light – Wait to extinguish” Moved after “Lane A – ON” Fuel Pump Check pressure limits were 40.5 to 46.5	11/08/19
	4.14	Added Lights – ON STEADY	
	4.17	“NAV & Land Light Switches” was “Electrical Switches” Added ELT – CHECK OFF Added engine cooling run for hot wx operations	
	7.2	Added information for optional 3 blade propeller	
	8.6	Added ULS spark plug information. Corrected 912iS spark plug gap	
6	1.2	Revised Top Speed	08/04/20
	2.8	Removed Fuel Pressure Caution range and extended Normal range from 40.6 psi to 55.1 psi	
	4.5	Removed “Fuel Pressure – CHECK above 43.5 psi (3 bar)”	
	4.7	“... check fuel pressure 40.6 to 55.1 psi” was “... check fuel pressure 40.6 to 50.8 psi”	
	5.7.1	Revised Cruise Performance Table	
	7.4	Replaced GMC 307 with GMC 507 in Figure 7-4	
7		Added section “Voltage Regulator Failure Rotax 912ULS (B&C AVC1 Voltage Regulator Installed)”	01/08/21
		Clarify hot day ground operation engine RPM guidance	
8	All Pages	Added VAD-10003 to footer	01/21/22
	3.5.3.1, 3.6.2, 3.6.3	Added checklist item for Smart Glide if equipped with Garmin G3X	
	4.5	Added “Throttle Position (Warm) – 35% +5%”	
	4.17	Updated “Throttle – IDLE” to “Throttle – 2000 RPM” Added “Note: Turning off Lane A & B should be done...”	
	7.11	Revised fuel system figure nomenclature	
9	Cover Page	Added VAD-10003 to title	04/25/23
	i	Added VAD-10003 to title	
	4.5, 4.17	Added new procedures for starting and turning off the engine	
	3.6, 7.9	Added emergency equipment and egress hammer and egress procedures	
	3.5.3.1, 3.6.2, 3.6.3	Added guidance for use of Garmin smart glide in emergency situations. Added further guidance for vapor lock, added restrictions for use of MOGAS per ASTM and UK certification requirements.	

Rev	Section	Change	Date
10	INTRODUCTION	Changed Data Location and Contact	02/22/24
	1.2, 2.3, 5.3	Revised stall speeds for V_{SO} and V_S . Added stall speed for V_{S1} Stall Flaps ½ Down. Expressed stall speeds as IAS and CAS.	
	6.5	Updated empty weight example.	
	7.3	Updated empty weight.	
	1.2	Revised unusable fuel to 0.5 gal Stall speeds given as KIAS and KCAS	
	5.2	Added note that near stall calibrated and indicated speeds may diverge.	
11	1.2	Added glide ratio	6/30/24
	2.12	Added placard descriptions for placards required for UK certification.	
	2.3	Added UK V_{FE} KIAS limitation	
	3.7.2	Added altitude loss information for level and turning stall recovery.	
12	1.2	Added Electrical System Description	12/05/25
	2.3	Maximum crosswind changed to a demonstrated speed	
	2.4	Corrected Temperature Unit Typo	
	3.5.2.1, 3.5.2.2, 3.6.2	Add "Seat Belt Harness – TIGHTEN LAP & SHOULDER"	
	3.7.8	Added Alternate EFIS Reboot Procedure	
	7.4, 7.7.5, 7.6	Updated reference to GTR 205x from GTR 200B	
	8.4	Added Oil Change Quantity	
13	2.2	Removed "IFR" from Flight Operation Warnings	01/24/26
	2.12	Removed Fuel Shutoff Placard Description	
	3.3.1, 3.3.2, 3.5.2.1, 3.5.2.2, 3.6.2, 4.3, 4.4, 4.7	Fuel Shut-Off Valve changed to ULS ONLY	
	3.5.3.2	Removed Fuel Shut-Off	
	6.6	Updated Figure 6-1 and 6-2 to an improved graphic.	
	7.4	Updated Figure 7-2, removed "SEE DIAGRAMS" Updated Figure 7-5 to Fuel Shut-off (ULS ONLY)	
	7.8	Updated Figure 7-11 to show new Fuel system	
14	2.12	Added PARKING BRAKE and ALT AIR ON/OFF	05/18/26
	3.3.1, 3.3.2, 3.7.10, 4.3, 4.4	Added Alt Air Check	
	3.7.2, 3.7.7, 3.7.10, 4.3, 7.7.5	Added "If Installed" to Stall warning	
	4.3	Moved Pitot check to Wing Added "If installed" to nose pitot	
	4.6, 4.17, 8.10	Added Parking Brake Check	
	7.4	Updated Figure 7-5 to include Alt Air Updated Figure 7-6 to show a new control stick	
7.9	Updated Figure 7-13 to show Egress Hammer & Holder		

TABLE OF CONTENTS

SECTION 1	GENERAL INFORMATION	1-1
SECTION 2	LIMITATIONS	2-1
SECTION 3	EMERGENCY PROCEDURES	3-1
SECTION 4	NORMAL PROCEDURES	4-1
SECTION 5	PERFORMANCE	5-1
SECTION 6	WEIGHT & BALANCE & EQUIPMENT LIST	6-1
SECTION 7	DESCRIPTION OF AIRPLANE & SYSTEMS	7-1
SECTION 8	HANDLING & SERVICING	8-1
SECTION 9	SUPPLEMENTS	9-1

INTRODUCTION

The aircraft is compliant with the following ASTM standards:

Design	F 2245
Construction	F 2563
Continued Airworthiness	F 2295
Pilot Operating Handbook	F 2746

Manufacturer Contact Information for an SLSA Aircraft:

Van's Aircraft, Inc.
14401 Keil Rd NE
Aurora, Oregon 97002
Phone: 503-678-6545

Data Location and Contact:

ASTM F2746 6.4.3 contact information is listed on the Vans Aircraft web site.

THIS PAGE INTENTIONALLY LEFT BLANK

SECTION 1

GENERAL INFORMATION

INDEX

1.1	GENERAL INFORMATION	1-1
1.2	SUMMARY OF PERFORMANCE SPECIFICATIONS	1-2

1.1 GENERAL INFORMATION

This manual has been prepared to inform the pilot of the features and systems incorporated in the RV-12iS. Recommended operating procedures and performance data are provided so that maximum utilization can be obtained with the utmost of safety, economy, and serviceability.

A companion manual, the RV-12iS iS Flight Training Supplement, mirrors the content of this manual but presents operating procedures at a greater level of detail than can effectively be presented in this manual.

It is strongly recommended that the pilot be familiar with the aircraft, the RV-12iS FTS, and this manual prior to flight.

The pilot must have either an electronic copy or a paper copy of this POH in the aircraft during flight.

The words “**WARNING**”, “**CAUTION**”, and “**NOTE**” are used throughout the manual with the following definitions:

WARNING

An operating procedure, practice, or condition, etc. which may result in injury or fatality if not carefully observed or followed.

CAUTION

An operating procedure, practice, or condition, etc. which if not strictly observed may damage the aircraft or equipment.

NOTE

An operating procedure, practice or condition.

Sections or items pertaining to the Rotax 912 ULS or Rotax 912 iS engine type will be clearly marked. If a Section or item is not marked for a particular engine it applies to both engine types.

1.2 SUMMARY OF PERFORMANCE SPECIFICATIONS

Gross Weight

1320 lb

Performance Rotax 912 iS

(at gross weight with wheel pants)

Top Speed	120 KIAS
Cruise (7,500 ft, 5,500 RPM)	104 KIAS
Cruise (7,500 ft, 5,000 RPM)	92 KIAS
Stall Flaps Down, V_{SO}	45 KIAS 41 KCAS
Stall Flaps $\frac{1}{2}$ Down, V_{S1}	48 KIAS 44 KCAS
Stall Clean, V_S	50 KIAS 45 KCAS
Range (7,500 ft, 5,500 RPM)	493 nm*
Range (7,500 ft, 5,000 RPM)	547 nm*
Rate of Climb, V_Y , 75 KCAS, sea level)	1,000 ft/min

Performance Rotax 912 ULS

(at gross weight with wheel pants)

Top Speed	120 KIAS
Cruise (7,500 ft, 5,500 RPM)	102 KIAS
Cruise (7,500 ft, 5,000 RPM)	91 KIAS
Stall Flaps Down, V_{SO}	45 KIAS 41 KCAS
Stall Flaps $\frac{1}{2}$ Down, V_{S1}	48 KIAS 44 KCAS
Stall Clean, V_S	50 KIAS 45 KCAS
Range (7,500 ft, 5,500 RPM)	368 nm*
Range (7,500 ft, 5,000 RPM)	440 nm*
Rate of Climb, V_Y , 75 KCAS, sea level)	900 ft/min

Glide Ratio 10.6:1

Total Fuel Capacity

20.2 US Gallons

Electrical System

14V System
12V Battery

Total Unusable Fuel

0.5 US Gallons

Approved Fuel Types

100 LL or UL94 Aviation Fuel or 91 AKI Premium Unleaded Automotive (See Fuel Type - Vapor Lock, 8.3 Fuel and SL-00078).

Ethanol blended fuels of up to 10% (E10) are compatible with all fuel system components.

Maximum Engine Power

100 hp @ 5,800 RPM (5 minutes maximum)

*No allowance for taxi, takeoff, climb, descent, or reserve

SECTION 2

LIMITATIONS

INDEX

2.1	INTRODUCTION	2-1
2.2	FLIGHT OPERATIONS	2-2
2.3	AIRSPPEED LIMITATIONS	2-3
2.4	CEILING	2-3
2.5	FLIGHT LOAD FACTORS	2-4
2.6	PROHIBITED MANEUVERS	2-4
2.7	POWERPLANT LIMITATIONS	2-4
2.8	FUEL LIMITATIONS	2-4
2.9	AIRSPPEED/POWERPLANT INDICATOR MARKINGS	2-6
2.10	OPERATING LIMITATIONS	2-6
2.11	PASSENGER WARNING	2-6
2.12	MISCELLANEOUS PLACARDS	2-7

2.1 INTRODUCTION

This section lists all power plant and airframe operating limitations. These limitations are also indicated in the aircraft in the form of placards, instrument color markings, and audio warnings. The aircraft placards, instrument color markings, and audio warnings are to be the authority if an inconsistency exists with this manual.

WARNING

All operating limitations must be strictly adhered to for reasons of safety and serviceability.

2.2 FLIGHT OPERATIONS

The RV-12iS iS is designed for operation in the Light Sport Category.

Daytime flight in VFR conditions only is approved providing that the aircraft is operating as specified under Part 91 of the Federal Air Regulations (F.A.R.'s).

WARNING

Night flight is prohibited (unless equipped with optional lighting).

WARNING

Flight in IMC conditions is prohibited.

WARNING

Flight into known icing conditions is prohibited.

The minimum operating temperature of the aircraft is -20°F (-30°C) and is limited by the EFIS.

Drain the fuel system if the temperature falls below -30°F [-34°C].

Satisfactory engine cooling and cooling of critical electrical components has been demonstrated for this aircraft at an outside air temperature of 100°F (38°C). This is not to be considered an operating limitation.

2.3 AIRSPEED LIMITATIONS

Airspeed Designation	KIAS	KCAS
Stall Flaps Down at gross weight 1320 lbs. V_{SO}	45	41
Stall Flaps ½ Down at gross weight 1320 lbs. V_{S1}	48	44
Stall at gross weight 1320 lbs. V_S	50	45
Flap Operating Range $V_{SO} - V_{FE}$	45-82	
Flap Operating Range $V_{SO} - V_{FE}$ (UK CERTIFICATION)	45-74	
Normal Operating Range green arc	45-108	
Operating Maneuvering V_O 1320 lbs.	90	
Operating Maneuvering V_O 850 lbs.	72	
Maximum Structural Cruise V_{NO}	108	
Caution Range yellow arc	108-136	
Maximum Demonstrated Direct Crosswind Component	11	
Maximum Wind Limitation (Ground Operations)	30	
Never Exceed V_{NE} red line below 16,000 feet	136	
Best angle of climb V_x	60	
Best rate of climb V_y	75	
 Airspeed Designation	 KTAS	
Never Exceed V_{NE} red line	136	

Airspeed Descriptions

KCAS	Knots Calibrated airspeed is indicated airspeed (IAS) corrected for installation and instrument error.
KIAS	Knots Indicated airspeed assumes zero instrument error only.
KTAS	Knots speed of the aircraft relative to the air mass in which it is flying.
V_{NE}	Maximum safe airspeed, not to be exceeded at any time.
V_{NO}	Not to be exceeded except in smooth air and then with caution.
V_{FE}	Not to be exceeded with flaps extended.
V_O (V_A)	No full or abrupt control movements allowed above this airspeed.

2.4 CEILING

Rotax 912 iS	Service Ceiling Estimated 17,300 ft
Rotax 912 ULS	Service Ceiling Estimated 13,000 ft

OAT above 80 deg F (26 deg C) and or Fuel Temperature above 68 deg F (20 deg C):

Rotax 912ULS may operate only using approved fuel

Rotax 912iS 6000 ft density altitude unless using approved fuel

(See 2.8 Fuel Limitations and SL-00078)

At high altitudes the provision for oxygen for occupants is necessary. Legal requirements for the provision of oxygen should be adhered to.

2.5 FLIGHT LOAD FACTORS

Category

Light Sport Category

Limit Load Factor

+4.0g/-2.0g

2.6 PROHIBITED MANEUVERS

AEROBATICS PROHIBITED!

Intentional spinning prohibited

2.7 POWERPLANT LIMITATIONS ROTAX 912 iS / ROTAX 912 ULS

Rated Horsepower

100 hp @ 5,800 RPM (5 minutes maximum)

95 hp @ 5,500 RPM (continuous)

Tachometer

Caution Range (yellow arc)

1,400 to 1,800 RPM

Normal Range (green arc)

1,800 to 5,500 RPM

Caution Range (yellow arc)

5,500 to 5,800 RPM

Maximum (red line)

5,800 RPM

Coolant

Maximum (red line)

248° F

Oil Temperature

Minimum

120° F

Normal in Cruise

190° to 230° F

Caution Range (yellow arc)

230° F to 248° F

Maximum (red line)

266° F

Oil Pressure

Minimum at Cruise

29 psi

Maximum at Cruise

73 psi

Maximum – Cold (red line)

102 psi

Minimum at Idle (red line)

12 psi

Exhaust Gas Temperature

Maximum

1,742°F

2.8 FUEL LIMITATIONS

Fuel Pressure Rotax 912 iS

Minimum (red line)

40.6 psi

Normal Range

40.6 to 55.1 psi

Maximum (red line)

55.1 psi

Fuel Pressure Rotax 912 ULS

Minimum (red line)

2.2 psi

Normal Range

2.2 to 7.2 psi

Maximum (red line)

7.2 psi

Fuel Capacity

Capacity

20.2 US Gallons

Unusable Fuel

Climbs and sideslips

0.5 US Gallons

Fuel Type

100 LL or UL94 Aviation Fuel or 91 AKI Premium Unleaded Automotive (See Fuel Type - Vapor Lock and 8.3 Fuel, See SL-00078).

Ethanol blended fuels of up to 10% (E10) are compatible with all fuel system components.

CAUTION

Long term storage of aircraft with ethanol fuel may cause damage. See SB 13-03-21.

CAUTION

Prolonged use of Aviation Fuel Avgas 100LL results in greater wear of valve seats and greater combustion deposits inside cylinders due to higher lead content. It is therefore suggested to avoid using this type of fuel unless strictly necessary.

NOTE

See the latest version of the Rotax Operators Manual and SI 912 i-001 / SI 912-016 to determine other approved fuel types, limitations, and maintenance considerations.

Fuel Type - Vapor Lock**WARNING**

Use of 91 AKI Premium Unleaded Automotive gas especially winter blend fuels or any fuel with high RVP (Reid Vapor Pressures) may lead to the formation of vapor lock at elevated OAT above 80 deg F and fuel temperatures above 68 deg F.

There is an increased risk of vapor lock with a heat-soaked engine. See other procedures in the manual about opening the canopy and oil door, engine cooldown runs, and running the fuel pump before startup to minimize the risk of vapor lock.

OAT above 80 deg F (26 deg C) and or Fuel Temperature above 68 deg F (20 deg C):

Rotax 912ULS must use 100LL at any altitude to prevent the formation of vapor lock or mixed fuel (pending approval as defined below).

Rotax 912iS must use 100LL for operations above 6000 ft density altitude to prevent the formation of vapor lock or mixed fuel (pending approval as defined below).

Mixed Fuel: (Pending Approval – See SL-00078) A 50% mixture by volume of 100LL and 91AKI Premium Unleaded Automotive fuel for operation at elevated temperatures to inhibit the formation of vapor lock.

NOTE

Van's Aircraft is in the process of testing but has not yet approved UL94 Aviation Fuel for operation above 80 deg F for the Rotax 912ULS and above 6000 ft DA for the Rotax 912iS.

See Also 2.4 Ceiling , 3.7.14 Vapor Lock, 4.3 Preflight Inspection (Run Fuel Pump Warning), 4.17 Hot Weather Shutdown, 8.3 Fuel

2.9 AIRSPEED/POWERPLANT INDICATOR MARKINGS

Limitations are displayed electronically.

2.10 OPERATING LIMITATIONS

Limitations are displayed electronically.

2.11 PASSENGER WARNING

Displayed on instrument panel.

“PASSENGER WARNING

THIS AIRCRAFT WAS MANUFACTURED IN ACCORDANCE WITH LIGHT SPORT AIRCRAFT AIRWORTHINESS STANDARDS AND DOES NOT CONFORM TO STANDARD CATEGORY AIRWORTHINESS REQUIREMENTS NO INTENTIONAL SPINS”

**“WARNING!
FLIGHT INTO IMC IS PROHIBITED”**

2.12 MISCELLANEOUS PLACARDS

- Registration number on outside of aircraft, 2 places
- Stainless steel data plate on outside of aircraft
- Registration number on instrument panel
- “LIGHT-SPORT” (SLSA) placard on baggage bulkhead
- “EXPERIMENTAL” (ELSA) placard on baggage bulkhead
- Instrument panel switches and fuses are all labeled
- “OPEN” (near canopy latch on outside of rear window)
- Fuel capacity and type near fuel cap
- “THROTTLE” forward of throttle
- Throttle position/engine mode indication strip near throttle
- “CABIN HEAT” between cabin heat knobs, “PULL ON” on each knob
- “PARKING BRAKE” on parking brake knob
- “ALT AIR ON/OFF” near alt air knob
- “300 LB WEIGHT LIMIT PER SEAT” between seats on tunnel cover
- “BAGGAGE CAPACITY MAXIMUM 75 LB” on baggage bulkhead
- “NO PUSH” placards (2 places) on anti-servo tab
- “AUTOPILOT DISCONNECT” adjacent to switch (If optional Autopilot installed)
- “USB POWER” near USB power outlet (5 Volt, 4.8 Amp max)
- “ELT” label on baggage area floor and incorporated into instrument panel switch
- “FLAPS” “UP” “DOWN” near flaps switch
- “PTT” near push-to-talk switch
- “DIMMER” near cockpit lighting dimmer knob

Placards for UK Certification (in view of the pilot)

- Empty (actual) and Maximum weight
- Minimum pilot weight and loading conditions when flown solo
- Fuel load limitations for the range of allowable cockpit loads

THIS PAGE INTENTIONALLY LEFT BLANK

SECTION 3

EMERGENCY PROCEDURES

INDEX

3.1	INFORMATION	3-3
3.2	ABNORMAL ENGINE INDICATIONS	3-3
	3.2.1 LANE FAULT INDICATIONS	3-3
	3.2.2 EFIS INDICATIONS	3-4
	3.2.3 LOSS OF SENSOR VALUES WITH LANE SHUTDOWN	3-4
3.3	FIRE	3-5
	3.3.1 ENGINE FIRE DURING START	3-5
	3.3.2 ENGINE FIRE IN FLIGHT	3-5
	3.3.3 ELECTRICAL FIRE	3-6
3.4	GENERATOR/ELECTRICAL FAILURE	3-6
	3.4.1 GENERATOR A OR B FAILURE ROTAX 912 iS	3-6
	3.4.2 GENERATORS A & B FAILURE ROTAX 912 iS	3-7
	3.4.3 GENERATOR FAILURE ROTAX 912 ULS	3-6
	3.4.4 HIGH VOLTAGE ROTAX 912 iS/ULS	3-7
	3.4.5 VOLTAGE REGULATOR FAILURE ROTAX 912 ULS (Silent Hektik Regulator Installed)	3-7
	3.4.6 VOLTAGE REGULATOR FAILURE ROTAX 912 ULS (B&C AVC1 Voltage Regulator Installed)	3-8
3.5	ENGINE MALFUNCTION	3-8
	3.5.1 SPAR PIN OVERRIDE SWITCH	3-8
	3.5.2 ENGINE FAILURE ON TAKE-OFF	3-9
	3.5.3 ENGINE FAILURE IN FLIGHT	3-11
	3.5.4 PARTIAL POWER LOSS/ROUGH RUNNING	3-11
	3.5.5 ABNORMAL OIL PRESSURE/TEMPERATURE INDICATIONS	3-12
	3.5.6 ABNORMAL COOLANT TEMPERATURE INDICATIONS / OVERHEATING – ROTAX 912 iS	3-13
3.6	EMERGENCY LANDING	3-14
	3.6.1 PRECAUTIONARY LANDING APPROACH	3-14
	3.6.2 FORCED LANDING – COMPLETE POWER FAILURE	3-15
	3.6.3 DITCHING	3-16
3.7	UNUSUAL FLIGHT CONDITIONS	3-17
	3.7.1 SEVERE TURBULENCE	3-17
	3.7.2 STALLS	3-17
	3.7.3 SPINS	3-18
	3.7.4 RUNAWAY TRIM MOTOR	3-18
	3.7.5 LOSS OF TRIM TAB	3-19
	3.7.6 EMERGENCY DESCENT	3-19
	3.7.7 LOSS OF FLIGHT INSTRUMENTS (EFIS)	3-19
	3.7.8 EFIS REBOOT PROCEDURE	3-20
	3.7.9 IN-FLIGHT OVERSTRESS	3-20
	3.7.10 UNINTENTIONAL FLIGHT INTO ICING	3-20

Continued on next page

3.7.11	LOSS OF FLIGHT CONTROLS	3-21
3.7.12	LOSS OF BRAKE	3-22
3.7.13	CANOPY OPEN IN FLIGHT	3-22
3.7.14	VAPOR LOCK	3-23

3.1 INFORMATION

This section covers the recommended procedures to follow during abnormal, emergency and/or adverse flight conditions. As it is not possible to define every type of emergency that may occur, it is the pilot's responsibility to use sound judgment based on personal experience and knowledge of the aircraft to determine the best course of action.

It is considered mandatory that the pilot be familiar with this entire manual, in particular, Section 3 "Emergency Procedures" prior to flight.

NOTE

All airspeeds in this section are indicated knots airspeeds (KIAS) unless stated otherwise.

3.2 ABNORMAL ENGINE INDICATIONS ROTAX 912 IS

3.2.1 LANE FAULT INDICATIONS

See Figure 7-3 in Section 7 for location of LANE A and LANE B fault indicator lights on instrument panel.

LANE A	LANE B	Action on Ground	Action in Flight
OFF	FLASHING	Flight only to maintenance facility	Fly to destination at own discretion
FLASHING	OFF	Flight only to maintenance facility	Fly to destination at own discretion
OFF	ON	Do not fly aircraft	Precautionary Landing
FLASHING	FLASHING	Do not fly aircraft	Precautionary Landing
FLASHING	ON	Do not fly aircraft	Precautionary Landing
ON	OFF	Do not fly aircraft	Precautionary Landing
ON	FLASHING	Do not fly aircraft	Precautionary Landing
ON	ON	Do not fly aircraft	Precautionary Landing

NOTE

A flashing fault indicator light indicates an error of less severity than a permanently lit light. A Lane A or B light that is on indicates an error within the ignition and/or injection Lane and there will be a transfer of control to the error free Lane.

WARNING

A lane failure may result in the engine running in rich mode only (eco mode may not be possible). This may result in a significant increase in fuel consumption.

3.2.2 EFIS INDICATIONS

Dynon SkyView

A detailed list of faults reported by the Rotax 912 iS engine computer is shown under MENU > ENGINE MENU > FAULTS.

Normally, it should say NONE. Consult your Rotax service organization for details of what to do if a fault is shown.

Garmin G3X

Rotax 912 iS engine faults are indicated by a fault warning on the home screen. Fault descriptions can be viewed by entering Configuration Mode and selecting SYSTEM INFO > FADEC.

Consult your Rotax service organization for details of what to do if a fault is shown.

3.2.3 LOSS OF SENSOR VALUES WITH LANE SHUTDOWN

NOTE

LANE A and LANE B have different associated sensor inputs.

Not available sensor values if LANE A = OFF and LANE B = ON:

- Coolant temperature
- Exhaust gas temperatures
- Ambient temperature
- Ambient pressure
- Throttle lever position

Not available sensor values if LANE B = OFF and LANE A = ON:

- Oil temperature
- Oil pressure

3.3 FIRE

3.3.1 ENGINE FIRE DURING START

If the fire is believed to be confined to the intake or exhaust system (result of flooding engine):

- Continue cranking engine with starter until checklist completed
- Choke (912 ULS Only) – PUSH OFF
- Throttle – FULL OPEN
- Fuel Shut-Off Valve (912 ULS Only) – PULL UP – OFF
- Alt Air Valve – PUSH DOWN – OFF (IF INSTALLED)
- Fuel Pump Switches (912 iS Only) – BOTH OFF
- “Fuel Pump” Fuse (912 ULS Only) – PULL – REMOVE
- Inspect aircraft thoroughly for damage and cause prior to restart

If fire persists or is not limited to intake or exhaust system:

- Electrical Switches – ALL OFF
- Lane A & B (or Ignition Switches) – BOTH OFF
- Evacuate aircraft immediately
- If available, direct fire extinguisher through the air outlet tunnel at the bottom of the cowl

3.3.2 ENGINE FIRE IN FLIGHT

An engine fire in flight is typically the result of an oil or fuel leak coming in contact with the exhaust manifold.

To extinguish the fire, it is necessary to remove the heat source by shutting down the engine and initiating an emergency descent.

- Fuel Shut-Off Valve (912 ULS Only) – PULL UP – OFF
- Alt Air Valve – PUSH DOWN – OFF (IF INSTALLED)
- Fuel Pump Switches (912 iS Only) – BOTH OFF
- “Fuel Pump” Fuse (912 ULS Only) – PULL – REMOVE
- Lane A & B (or Ignition Switches) – BOTH OFF
- Air Vents and Cabin Heat – BOTH CLOSED
- Airspeed – INCREASE glide speed to find an airspeed which will provide an incombustible mixture without exceeding **Vne** (**Vno** if turbulence exists).
- Consider sideslip to divert smoke from pilot side
- Follow 3.6.2 “Forced Landing” procedures

WARNING
Do not attempt to restart engine.

3.3.3 ELECTRICAL FIRE

An electrical fire is usually indicated by an odor of hot or burning insulation.

- Electrical Switches – ALL OFF (leave Lane/Ignition Switches – ON)
- 30A “Gen Main Bus” Fuse – PULL – REMOVE
- Air Vent – OPEN if necessary for smoke removal and ventilation
- Use hand fire extinguisher if available
- Land immediately (or as soon as practical if location for safe landing is not available)

3.4 GENERATOR/ELECTRICAL FAILURE

WARNING

Failure of both generators will result in engine stoppage (912iS only).

Electrical fuel pump operation depends upon sufficient battery power.

Electric flaps and Stabilator trim operation depends on battery power.

3.4.1 GENERATOR A OR B FAILURE ROTAX 912 iS

Failure of Generator A or B is indicated by a steady discharge on the ammeter, a voltage indication of less than 13.0 volts. Failure of Generator A only is also indicated by flashing of both the Lane A and Lane B fault indicator lights.

Potential failure of the remaining generator will result in engine stoppage.

If the EMS power supply (Generator A) fails the ECU automatically switches one-time over to the second EMS power supply (Generator B). No charging of the aircraft battery occurs during this mode.

- Non-Essential Electrical Equipment – OFF
- Land as soon as possible as the battery and EFIS backup battery will furnish electrical power for a limited time only.

NOTE

Generator A is able to supply a limited amount of power to the main bus if the EMS Backup Battery Switch is turned ON. Turn off all non-essential electrical equipment first.

3.4.2 GENERATORS A & B FAILURE ROTAX 912 iS

Failure of Generators A & B will result in engine stoppage.

- Non-Essential Electrical Equipment – OFF
- EMS Backup Battery Switch – ON
- Follow 3.5.3 “Engine Failure in Flight” procedures
- Land as soon as possible using 3.6.1 “Precautionary Landing Approach” procedures.

3.4.3 GENERATOR FAILURE ROTAX 912 ULS

A generator failure is indicated by a steady discharge on the ammeter and voltage indication less than 12.0 volts.

- Non-Essential Electrical Equipment – OFF
- Land as soon as possible as the battery and EFIS backup battery will furnish electrical power for a limited time only.

3.4.4 HIGH VOLTAGE ROTAX 912 iS/ULS

A voltage in excess of 15 volts indicates a runaway generator.

- 30A “Gen Main Bus” Fuse – PULL – REMOVE immediately
- Non-Essential Electrical Equipment – OFF
- Land as soon as possible as the battery and EFIS backup battery will furnish electrical power for a limited time only.

3.4.5 VOLTAGE REGULATOR FAILURE ROTAX 912 ULS

(Silent Hektik Voltage Regulator Installed)

NOTE

The regulator has a voltage ramp-up schedule and will take 30 minutes to reach full output.

The voltage regulator will give a warning via the EFIS for one of three reasons (All three should be considered since there is only a single warning indication):

1. Overvoltage condition (steady light)
2. No generator output (steady light)

- Non-Essential Electrical Equipment – OFF
- Land as soon as possible as the battery and EFIS backup battery will furnish electrical power for a limited time only

Continued on next page

3. Over-temp condition (if EA-F4122 and SkyView is installed the light will flash)

This would most likely occur in elevated temperatures during lengthy ground operations, during a long climb at slow airspeed, or after extended periods of slow flight just above stall speed.

- Reduce angle of attack
- Increase airspeed
- If warning is given on the ground, increase RPM to force more air through the cooling duct

NOTE

Warning 2 above will occur on a Dynon system when the engine is not running.

3.4.6 VOLTAGE REGULATOR FAILURE ROTAX 912 ULS

(B&C AVC1 Voltage Regulator Installed)

The voltage regulator will give a warning via the EFIS if the regulator detects an overvoltage condition.

- Non-Essential Electrical Equipment – OFF
- Land as soon as possible as the battery and EFIS backup battery will furnish electrical power for a limited time only

3.5 ENGINE MALFUNCTION

3.5.1 SPAR PIN OVERRIDE SWITCH

The spar pin unsafe override switch is a lighted momentary contact switch that serves primarily as an indicator of a potential unsafe spar pin condition. The starter circuit is disabled when the indicator is lit.

Should the spar pin indication system develop a fault at the same time an in-flight engine re-start is necessary, the disable function may be overridden by pressing the switch while activating the starter.

See Figure 7-3 in Section 7 for location of the spar pin override switch.

3.5.2 ENGINE FAILURE ON TAKE-OFF

3.5.2.1 ENGINE FAILURE ON TAKE-OFF ROTAX 912 iS

WARNING

In the event of engine failure while airborne, the control stick must be moved forward IMMEDIATELY to prevent loss of airspeed.

WARNING

Maintain flying speed at all times and do not attempt to turn back toward the runway unless sufficient altitude had been achieved.

- Airspeed – 60 KIAS (55 KIAS minimum)

Sufficient runway remains for landing:

- Throttle – CLOSED
- Land using maximum braking after touchdown.

If airborne and insufficient runway remains for landing, attempt an engine restart if altitude permits:

- Follow 3.5.3.1 “Engine Air Restart Rotax 912 iS” procedures

If no restart is possible:

- Select most favorable landing area ahead
- Flaps – FULL DOWN
- Fuel Shut-Off Valve (912 ULS Only) – PULL UP – OFF
- Ignition Switches – BOTH OFF
- Fuel Pump Switches – BOTH OFF
- Master Switch – OFF
- EMS Backup Battery Switch – OFF (If turned on previously above)
- 30A “Gen Main Bus” Fuse – PULL – REMOVE
- Seat Belt Harness – TIGHTEN LAP & SHOULDER
- Touchdown with minimum airspeed, particularly if landing on rough terrain.
- ELT – Consider ACTIVATING for off-airport landing

3.5.2.2 ENGINE FAILURE ON TAKE-OFF ROTAX 912 ULS

WARNING

In the event of engine failure while airborne, the control stick must be moved forward IMMEDIATELY to prevent loss of airspeed.

WARNING

Maintain flying speed at all times and do not attempt to turn back toward the runway unless sufficient altitude had been achieved.

- Airspeed – 60 KIAS (55 KIAS minimum)

Sufficient runway remains for landing:

- Throttle – CLOSED
- Land using maximum braking after touchdown.

If airborne and insufficient runway remains for landing, attempt an engine restart if altitude permits:

- Follow 3.5.3.2 “Engine Air Restart Rotax 912 ULS” procedures

If no restart is possible:

- Select most favorable landing area ahead
- Flaps – FULL DOWN
- Fuel Shut-Off Valve (912 ULS Only) – PULL UP – OFF
- Ignition Switches – BOTH OFF
- Fuel Pump Switches – BOTH OFF
- Master Switch – OFF
- 30A “Gen Main Bus” Fuse – PULL – REMOVE
- Seat Belt Harness – TIGHTEN LAP & SHOULDER
- Touchdown with minimum airspeed, particularly if landing on rough terrain.
- ELT – Consider activating for off-airport landing

3.5.3 ENGINE FAILURE IN FLIGHT

3.5.3.1 ENGINE AIR RESTART ROTAX 912 iS

- Maintain Airspeed – 60 KIAS minimum (see note below)
- Smart Glide – Hold Direct-To Button on G3X (Garmin Only)
- Lane A & B Switches – BOTH ON
- EMS Backup Battery Switch – ON
- Fuel Pump Switches – BOTH ON
- Fuel Shut-Off Valve (912 ULS Only) – CHECK ON – DOWN
- Throttle – SET TO 55% - 65% OPEN
- Spar Pin Override Switch – HOLD DOWN
- Ignition Key – ENGAGE
- If restart not possible, change throttle settings in attempt to restart
- Follow 3.6.2 “Forced Landing” procedures if unable to restart

NOTE

The engine starter must be engaged in flight should the propeller stop windmilling.
Propeller will not windmill below 80 KIAS.

3.5.3.2 ENGINE AIR RESTART ROTAX 912 ULS

- Maintain Airspeed – 60 KIAS minimum (see note below)
- Ignition Switches – BOTH ON
- Choke – CHECK OPEN – PUSH
- Spar Pin Override Switch – HOLD DOWN
- Ignition Key – ENGAGE
- If restart not possible, change throttle and/or choke settings in attempt to restart
- Follow 3.6.2 “Forced Landing” procedures if unable to restart

NOTE

The engine starter must be engaged in flight should the propeller stop windmilling.
Propeller will not windmill below 80 KIAS.

3.5.4 PARTIAL POWER LOSS/ROUGH RUNNING

- Follow the 3.5.2 “Engine Air Restart” procedures (Ignition Key – ENGAGE only required if engine stops completely)
- Land as soon as possible using 3.6.1 “Precautionary Landing Approach” procedures
- If descending results in the engine performance improving and increasing fuel pressure vapor lock may be present. See 3.7.14 “Vapor Lock”

3.5.5 ABNORMAL OIL PRESSURE/TEMPERATURE INDICATIONS

Oil pressure and temperature problems are usually related with one affecting the other. Before any drastic action is taken, cross check other engine instruments and control settings in an attempt to determine the source of the problem.

High Oil Temperature

High oil temperature (commonly related to overheating, read below) could be a result of loss of oil. If the situation remains unchecked, oil pressure usually drops resulting in possible engine damage. Power should be reduced to minimum necessary and land as soon as practical.

- Throttle – RPM reduce to MINIMUM NECESSARY
- PERFORM precautionary landing as soon as able

Low Oil Pressure

Little or no oil pressure is usually caused by a failed pressure relief valve, pump, loss of oil, high oil temperature or a defective oil pressure sending unit. A landing should be made as soon as practical using minimum RPM changes. Plan a “Precautionary Landing Approach” as complete engine failure is possible at any time.

- Throttle – RPM minimum adjustment
- PERFORM precautionary landing as soon as able

High Oil Pressure

High oil pressure is admissible for a short period at cold start. Should high oil pressure occur in flight, reduce power to the minimum necessary; land as soon as practical.

- Throttle – RPM reduce to MINIMUM NECESSARY
- PERFORM precautionary landing as soon as able

High Oil Temperature – Ground

High oil temperatures on the ground are usually related to high ambient temperatures and excessive engine idling, particularly with a right crosswind (which reduces airflow through the engine cowl & radiator).

- Throttle – 2,500-3,000 RPM
- Turn aircraft turned into the wind, if possible

High Oil Temperature – Flight

High oil temperatures in flight are usually related to low airspeed and/or extreme climb angle.

Should high oil temperature occur in flight:

- Reduce pitch angle
- Increase airspeed

3.5.6 ABNORMAL COOLANT TEMPERATURE INDICATIONS / OVERHEATING – ROTAX 912 iS

High Coolant Temperature – Ground

High coolant temperatures on the ground are usually related to high ambient temperatures and excessive idling, particularly with a right crosswind (which reduces airflow through the engine cowl & radiator).

- Throttle – 2,500-3,000 RPM
- Turn aircraft turned into the wind, if possible.

High Coolant Temperature – Flight

High coolant temperatures in flight are usually related to low airspeed and/or extreme climb angle.

Should high coolant temperature occur in flight:

- Reduce pitch angle
- Increase airspeed

3.6 EMERGENCY LANDING

NOTE

An egress hammer must be carried in the aircraft at all times within reach of each occupant. See 7.9 Emergency Equipment. If the canopy cannot be opened, break out the canopy/rear window with an egress hammer, and crawl through the opening.

NOTE

The aircraft is equipped with a canopy made of polycarbonate that is designed to shatter under load. The shape of the canopy is designed to be slightly proud of the roll bar such that when the aircraft is overturned the canopy will shatter on impact.

There are many variables which may prevent the canopy from shattering. Be prepared to use an egress hammer to break or enlarge an opening in the canopy to exit the aircraft.

3.6.1 PRECAUTIONARY LANDING APPROACH

A precautionary landing approach should be used whenever power is still available but a complete power failure is considered imminent. Maintain a higher and closer pattern than normal in attempt to remain in gliding distance of the intended touchdown point.

Use the normal landing procedures and in addition:

- Airspeed – 60 KIAS recommended (55 KIAS minimum)
- Throttle – CLOSED when in gliding distance of runway
- Flaps – LOWER AS NEEDED to increase approach descent angle

NOTE

Slipping the aircraft by cross controlling the rudder and ailerons will increase the rate of descent both with and without flaps. If a crosswind exists, place the lower wing into the wind.

3.6.2 FORCED LANDING (Complete Power Failure)

If the engine cannot be restarted in flight, trim the aircraft to the recommended glide speed. Remain within gliding distance of the intended point of landing. Maintain a higher and closer pattern than normal making allowance for wind. Extending flaps or slipping the aircraft can lose additional altitude. Diving the aircraft in an attempt to lose altitude when flying into a headwind will only increase the required landing distance.

- Airspeed: Maximum gliding distance – **63 KIAS**
Minimum rate of descent airspeed – **59 KIAS**
- Smart Glide – Hold Direct-To Button on G3X (Garmin Only)
- Fuel Shut-Off Valve (912 ULS Only) – PULL UP – OFF
- “Fuel Pump” Fuse (912 ULS Only) – PULL – REMOVE
- Fuel Pump Switches (912 iS Only) – BOTH OFF
- Flaps – UP to maximize glide range
- Transponder – 7700
- ELT – ACTIVATE for off-airport landing
- Radio – MAYDAY 121.5 MHz (or frequency in use)
- Seat Belt Harness – TIGHTEN LAP & SHOULDER
- Attempt to position the aircraft approximately 1,000 feet above ground level (AGL) when on downwind and abeam the intended point of landing.
- Lane A & B (or Ignition Switches) – BOTH OFF
- Final Approach
 - a) Airspeed – 55-60 KIAS
 - b) Flaps – DOWN when intended point of landing assured

WARNING

Electric flap operation depends on battery power.

- Master Switch – OFF
- 30A “Gen Main Bus” Fuse – PULL – REMOVE
- Touchdown with minimum airspeed, particularly if landing on rough terrain.

3.6.3 DITCHING

Should it become necessary to make a forced landing over water:

- APPROACH INTO WIND if high winds are evident
- APPROACH PARALLEL TO SWELLS with light winds
- Airspeed: Maximum gliding distance – **63 KIAS**
Minimum rate of descent airspeed – **59 KIAS**
- Smart Glide – Hold Direct-To Button on G3X (Garmin Only)
- Fuel Pump Switches (912 iS Only) – BOTH OFF
- “Fuel Pump” Fuse (912 ULS Only) – PULL – REMOVE
- ELT – ACTIVATE
- Transponder – 7700
- Radio – MAYDAY 121.5 MHz
- Lane A & B (or Ignition Switches) – BOTH OFF
- Flaps – DOWN
- Master Switch – OFF
- 30A “Gen Main Bus” Fuse – PULL – REMOVE
- Contact the water with minimum airspeed and a NOSE HIGH attitude
- After coming to complete stop – EXIT AIRCRAFT

NOTE

Aircraft cannot be depended upon to provide flotation after contacting the water.

3.7 UNUSUAL FLIGHT CONDITIONS

3.7.1 SEVERE TURBULENCE

To prevent overstressing the aircraft do not exceed 108 KIAS in rough air. To minimize personal discomfort, decrease the airspeed below 90 KIAS. Maintain a level flight attitude rather than flying by reference to the EFIS as the pitot-static indications may become very erratic. Disengage the autopilot if applicable.

Turbulence will agitate fuel and possibly increase the risk of vapor lock.

3.7.2 STALLS

The RV-12iS stall characteristics are conventional. If installed, the RV-12iS is equipped with a vane-type stall warning buzzer that activates approximately 7 KIAS above stall speed. For aircraft equipped with a Garmin Nav/Com Avionics System, the stall warning buzzer can be turned off by pressing the "AUX" button on the Audio Panel.

The aircraft is equipped with an AOA indicator with a three color range on the EFIS display accompanied by aural tone. Refer to your EFIS pilots guide for specific details.

For aircraft equipped with a Garmin Avionics System the ESP function will become active before the stall occurs, gradually pushing back on the control stick with increasing force as the stall condition is reached. This feature may be turned off for stall training. To turn off the ESP function select the AP annunciator bar at the top of the Flight Instruments area of the EFIS screen. When the Automatic Flight Control System screen appears, select ESP and turn it off.

Aileron control response in a fully stalled condition is marginal. Large aileron deflections will aggravate a near stalled condition and their use is not recommended to maintain lateral control. The rudder is very effective and should be used for maintaining lateral control in a stalled condition with the ailerons placed in a neutral position.

To recover from a stall, proceed as follows:

- Stabilator– RELAX back pressure on control stick.
- Throttle – FULL OPEN
- Rudder – To maintain lateral control

If the throttle is applied immediately altitude loss in a level or turning stall will be less than 60 feet.

See RV-12iS FTS for further information.

3.7.3 SPINS

If a spin is inadvertently entered, immediate recovery should be initiated. The recovery procedure is as follows:

- Throttle – CLOSED
- Rudder – FULL OPPOSITE direction of rotation
- Aileron – NEUTRAL POSITION
- Stabilator – SLIGHTLY FORWARD OF NEUTRAL
- Flaps – UP

When rotation stops (1/2 – 1 turn after recovery initiated):

- Rudder – NEUTRALIZE
- Attitude – RAISE NOSE SMOOTHLY to level flight attitude
- Throttle – Add power as required

WARNING

During the spin recovery, the airspeed will build very rapidly with a nose low attitude. Do not use full or abrupt stabilator control movements.

3.7.4 RUNAWAY TRIM MOTOR

If the trim motor should begin to run un-commanded in one or the other direction the following actions should be taken:

- Verify passenger is not depressing a trim button
- Activate trim in the opposite direction*
- “Trim / Start” Fuse – PULL – REMOVE as soon as runaway condition is recognized
- “Autopilot” Fuse – PULL – REMOVE (G3X Only)**
- STABILATOR – HOLD against out of trim condition
- AIRSPEED – reduce as a way to lessen the amount of stick force required to maintain level flight
- Land as soon as possible

NOTE

The Trim system is designed to “time-out” after six seconds of travel, if additional trim input is required, release and re-engage trim button.

* If the trim system receives conflicting trim inputs all power to the trim motor will be shut off.

** On Dynon equipped aircraft, or a Garmin equipped aircraft with the autopilot not engaged, trim power is used to change the position of the trim motor. When using a Garmin system with the autopilot activated, trim power commands the autopilot servo which direction the trim motor should move. The autopilot servo uses autopilot power to change the position of the trim motor.

3.7.5 LOSS OF TRIM TAB

Should the trim tab become disconnected from its actuation shaft, neither trim or anti-servo function will be available.

WARNING

Pitch forces will become very light, nonexistent or even self-driven. Pitch control commands will need to be based solely on visual pitch attitude and Indicated Airspeed references, not on normal control stick pressures.

- Airspeed – REDUCE to minimize possibility of trim tab flutter
- Control Stick – FIRM GRIP to prevent un-commanded pitch excursions.
- Land as soon as possible.

3.7.6 EMERGENCY DESCENT

If the need for an immediate descent to a lower altitude due to a smoke, pilot/passenger illness or other unusual situation occurs, perform an emergency descent mindful of airspeeds and load factors.

- Throttle – CLOSED
- Control Stick – BANK 30° TO 45° to maintain positive load factor
- Airspeed – Increase without exceeding **Vne**. (**Vno** if turbulence exists)
- Do not exceed 82 KIAS if flaps are extended
- Throttle – CLEAR the engine every 1,000 ft with a short application of power

3.7.7 LOSS OF FLIGHT INSTRUMENTS (EFIS)

Electronic Flight Information systems are subject to complete or partial failure due to electrical system, AHRS/ADC, GPS module or software failures. If an aircraft system electrical failure occurs, the internal back up battery will furnish EFIS electrical power for a limited time only.

In the event of a complete loss of display information, fly the airplane to the nearest suitable airport using the present power settings and normal maneuvers.

If installed, Stall Warning aural warnings will remain functional with the Master and Avionics Switches – ON.

- POWER – Based on throttle position and engine noise
- PITCH – Nose slightly below horizon

3.7.8 EFIS REBOOT PROCEDURE

DYNON SKYVIEW

- Buttons 1,2,5 – PRESS simultaneously

GARMIN G3X

- Buttons Menu, Back, & NRST – PRESS simultaneously
or
- Master Switch – OFF
- 30A “Gen Main Bus” Fuse – PULL – REMOVE
- 30A “Gen Main Bus” Fuse – REINSTALL
- Master Switch – ON

In the event of a complete loss of display information, fly the airplane to the nearest suitable airport using present power settings and normal maneuvers.

- POWER – Based on throttle position and engine noise
- PITCH – Nose slightly below horizon

3.7.9 IN-FLIGHT OVERSTRESS

Should an overstress occur due to exceeding the airspeed or load factor limits, aggressive maneuvering should be terminated immediately.

DO NOT under any circumstances make large control movements or subject the aircraft to additional G loadings above that required for straight and level flight.

- Throttle – REDUCE
- Airspeed – 65-75 KIAS
- Flaps – UP
- Land as soon as practical

After landing, the aircraft should be inspected per the Maintenance Manual prior to the next flight.

3.7.10 UNINTENTIONAL FLIGHT INTO ICING

- Leave the icing area (by changing altitude, course or both, in order to reach zones with a higher ambient temperature).
- Cabin Heat – ON
- Autopilot Switch – OFF
- ALT AIR – PULL UP – ON (IF INSTALLED)
- Throttle – RPM INCREASE in order to prevent ice build-up on the propeller blades. Do not exceed V_{NE} .
- Flaps – LEAVE RETRACTED
- ATC – Contact as required

CAUTION

Ice build-up increases the stalling speed. Carry extra speed on landing approach. If installed, the stall warning horn may not function.

See RV-12iS FTS for further information.

3.7.11 LOSS OF FLIGHT CONTROLS

3.7.11.1 STABILATOR CONTROL FAILURE

- Trim – Use as required for pitch control – slow response
- Flap – Will provide rapid pitch input and control response will be in reverse. (Flaps down will pitch the nose down). A high level of concentration is necessary to use flaps as pitch control.
- Throttle – INCREASE for nose-up pitch response, REDUCE for nose-down pitch response.

Control Lost One Direction – Use trim and opposing pitch input.

Control Locked – Use flap and trim (will function as an elevator and opposite of normal).

Free Floating – Use trim control to maintain pitch attitude.

Find a suitable airport with a long, wide runway (preferably aligned with the wind direction).

- Throttle – REDUCE
- Airspeed – 75 KIAS
- Flaps – HALF
- Airspeed – Trim to 60 KIAS
- Establish a long, shallow final approach to the runway
- Throttle – ADJUST TO CONTROL GLIDE PATH
- Short Final – Adjust trim and throttle for 50 KIAS
- Touchdown – Adjust trim and throttle to decrease the rate of descent.

NOTE

Half flaps allow more nose wheel clearance at touchdown than full flaps. In the event of a go around, advance the throttle slowly to avoid a sudden pitch up tendency.

See RV-12iS FTS for further information.

3.7.11.2 LOSS OF AILERON ROLL CONTROL

Find a suitable airport with a long, wide runway (preferably aligned with the wind direction). To avoid a cross control stall, maintain an airspeed 10 KIAS above normal.

- Rudder – Yaw changes will have a secondary affect as low rate roll control.
- Autopilot – Depending where the failure occurred, the autopilot may be used to control roll.

3.7.11.3 LOSS OF ELECTRIC FLAP CONTROL

Maintain an airspeed 5 KIAS above normal. Landing distance will be increased.

3.7.11.4 LOSS OF RUDDER CONTROL

Find a suitable airport with a long, wide runway (preferably aligned with the wind direction). If control has failed in one direction (most likely failure) land such that the controlled direction opposes any crosswind component. To avoid a cross control stall maintain an airspeed 10 KIAS above normal. Touchdown at minimum speed. After touchdown, shut off engine to minimize idle thrust.

3.7.12 LOSS OF BRAKE

If discovered upon touchdown, go around and consider the options below:

- Find a suitable airport with a long, wide runway
- Select a runway with a crosswind from the inoperative brake side
- Touchdown at minimum speed
- After touchdown oppose the weathervane effect with the operating brake. If no crosswind exists use aerodynamic rudder control to steer towards the inoperative brake side of the runway
- Once aerodynamic rudder control becomes ineffective, shut off the engine to minimize idle thrust
- Keep as much of the runway width available on the side of the operative brake for roll out or a hard-braking turn to a full stop

See RV-12iS FTS for further information.

3.7.13 CANOPY OPEN IN FLIGHT

The canopy latched warning that activates above a specified RPM level should prevent this condition from occurring. Should this event occur remember to fly the airplane. Do not try to reach for the canopy. The danger is reaching for the canopy, making an un-intentional pitch change that would stall the aircraft.

The canopy will find its own "open" position depending on airspeed. As the airplane reaches lower speeds the canopy will open further. Expect the canopy to open further when slowing down near the final touchdown point and during flare or when a pitch change is made in flight.

If the canopy comes open on takeoff and sufficient runway remains pull the throttle to idle immediately then land the aircraft straight ahead. If insufficient runway remains fly a normal pattern with a slightly higher than normal airspeed. An open canopy will create a significant amount of drag. Expect much higher than normal descent rates. Watch airspeed at all times and expect higher than normal stall speeds.

3.7.14 VAPOR LOCK

Sections in this handbook referencing vapor lock:

2.4 Ceiling, 2.8 Fuel Limitations, 4.3 Preflight Inspection (Run Fuel Pump Warning), 4.17 Hot Weather Shutdown, 8.3 Fuel

What is vapor lock? ASTM standards define the term "vapor lock," when used in reference to liquid fuel systems, as when the liquid fuel, while still in the fuel delivery system, changes state from liquid to gas (i.e., vaporizes), that causes either: a) fuel feed pressure to the propulsion unit to decrease below manufacturers specifications, b) transient loss of power, or c) complete stalling of the propulsion unit. That is a straightforward definition, but let's unpack that a little further.

It is important to not misdiagnose vapor lock. Loss of fuel pressure can also be caused by other factors such as a clogged filter or gascolator. Overlooking these possibilities can also lead to power loss or engine failure! Fatalities have occurred because clogged filters were assumed to be vapor lock. Stop, check that your fuel filters and return line orifice openings are clean.

Vapor lock is most commonly associated with:

- 1) High Operating Temperature. The ASTM standard associates vapor lock with temperatures at or above 80 deg F (26 deg C). High outside air temperature and/or a heat soaked engine or cockpit can raise the temperature of the fuel until components of that fuel begin to vaporize.
- 2) High vapor pressure fuel (high RVP)
- 3) Low atmospheric pressure (high density altitude)

NOTE

The most important factor in avoiding vapor lock is to use approved fuel for the flight conditions (See 2.8 FUEL LIMITATIONS). The use of volatile fuels (with high RVP such as wintertime blend MOGAS) will greatly increase the risk of vapor lock.

NOTE

Beware of fuel that may have been transported from a cold location to a warm area (trailed aircraft for example moved during the winter to a winter home in a warmer climate).

Think of RVP as a measure of volatility. The higher the RVP the more volatile the fuel (which is necessary in cold operating conditions to promote combustion). Additives such as butane easily boil off and become vapor at elevated temperatures and/or reduced atmospheric pressure. AvGAS RVP ranges from 5.5 to 7.1 psi while MOGAS RVP ranges from 7 to 14 psi depending on the location and season.

The "danger-zone" time period is in late spring when the OAT is high and fuel stations may still be selling winter-blend high RVP gas. Some fuel stations with large volume tanks and low sales rates may still be selling winter blend gasoline into the summer months (one reported case was near the end of June at an airport selling "clear" MOGAS). Note that since winter blend fuel tends to be cheaper than summer blend fuel, stations will buy a large quantity of winter blend to fill their tanks just before the spring EPA deadline. Fuel

stations may also mix winter or summer blends with each other. In short, do not trust that a fuel station will supply summer blend gasoline even though you may be well past the May 1st deadline.

It seems to be a common belief that vapor lock is associated with ethanol fuels. While ethanol fuel may be legally supplied at an RVP 1 psi higher than “clear” gasoline in the United States, ethanol alone does not contribute significantly to vapor lock. Rotax engines have been operated (against Rotax recommendations) on fuels with much higher concentrations of ethanol than 10% without reported occurrences of vapor lock. Additives in winter fuels (especially in northern climates with extreme cold) are the greatest contributors. Do not believe that if “clear” ethanol-free fuel is used you will be free from vapor lock.

The propensity for vapor lock can be reduced by preventing a rise in the temperature of the fuel.

- 1) Before shutdown run the engine for 2 mins at low power to flush as much heat out of the engine compartment as possible.
- 2) Most importantly, open the oil door after shutdown. The oil door is purposefully located above the oil tank (which post-flight will contain latent heat) and also next to the right carburetor on a ULS engine. Vents in the cowling (such as the louvers above the ignition coils) or the NACA inlet cooling Regulator B along with the lower cowling exit area, form a chimney effect after engine shutdown. Hot air venting from the top openings draws fresh, cool air in through the lower outlet of the cowling. This beneficial effect is greatly increased when the oil door is left open.
- 3) Since air is flowing in through the cowl exit, the chimney effect of cooling is most efficient if the tail of the aircraft is oriented into the wind. The next best option would be to point the aircraft nose into the wind.
- 4) Leave the canopy in the partially-open position to allow heat to escape from the cabin. Open the canopy and let the cockpit area cool off before flight.
- 5) Run the fuel pumps for 5 mins as you do your walk around. This will push fresh fuel through the system and flush out as much vapor as possible.
- 6) Pay attention to fuel pump tone or noise. A fuel pump moving air instead of fuel will generate a distinctly different sound.
- 7) If temperatures build in the runup area, remember to increase RPM in order to force more air through the coolant and oil coolers as well as the engine compartment. This may be counterintuitive. The EFIS will prompt you to increase RPM under these conditions if RPM is low and engine temperatures rise.
- 8) After takeoff reduce climb angle and increase forward speed.

In the RV-12iS using a Rotax 912iS, both fuel pumps are located behind the baggage compartment. These pumps increase the pressure in the fuel lines and help push fuel to the engine. This helps prevent the onset of vapor lock. These pumps must remain on for the entire flight.

It is important to not misdiagnose vapor lock. Loss of fuel pressure can also be caused by other factors such as a clogged fuel filter or gascolator. Overlooking these possibilities can lead to power loss or engine failure! Fatalities have occurred because clogged filters were assumed to be vapor lock even when the OAT was lower than that at which vapor lock would occur. Stop, check your fuel filters, and verify that the fuel return line orifice openings are clean.

In flight, recognize the signs of vapor lock will typically be a rough running engine, loss of power, and a loss of fuel pressure as you gain altitude. You may also hear a change in pitch and volume of fuel pump noise as air is pumped through them. If you have drained the fuel system and turned on the pumps, the pumps will initially only be pumping air. The sound will be similar. If you notice these signs, reduce altitude. If fuel pressure increases and power returns as the altitude is decreased, it is likely you are experiencing vapor lock. If you experience these conditions, do not continue to climb as this will only further reduce the fuel pressure. This pressure reduction may result in a complete powerplant failure.

Most importantly, use of the correct fuel is the best way to prevent vapor lock.

For further information see SL-00078 Vapor Lock

THIS PAGE INTENTIONALLY LEFT BLANK

SECTION 4

NORMAL PROCEDURES

INDEX

4.1	INTRODUCTION	4-1
4.2	AIRSPEDS FOR NORMAL OPERATIONS	4-1
4.3	PREFLIGHT INSPECTION	4-2
4.4	PRE-START	4-5
4.5	ENGINE START	4-6
4.6	TAXIING	4-7
4.7	BEFORE TAKE-OFF RUNUP	4-8
4.8	TAKE-OFF (Normal)	4-9
4.9	TAKE-OFF (Obstacle)	4-9
4.10	TAKE-OFF (Soft Field)	4-9
4.11	CLIMB	4-10
4.12	CRUISE	4-10
4.13	DESCENT & APPROACH	4-10
4.14	LANDING (Normal)	4-11
4.15	LANDING (Obstacle)	4-11
4.16	LANDING (Balked)	4-12
4.17	SHUTDOWN	4-13

4.1 INTRODUCTION

This section covers all recommended normal operating procedures using a checklist format whenever possible. The Flight Training Supplement (FTS) provides additional information if further explanation is required.

4.2 AIRSPEDS FOR NORMAL OPERATIONS

All recommended airspeeds in this section are **KNOTS INDICATED AIRSPEEDS (KIAS)** with the aircraft loaded to the maximum gross weight of 1320 lb at sea level conditions unless specified otherwise. For a list of airspeeds see Section 2.3.

4.3 PREFLIGHT INSPECTION

Cabin

- Canopy – OPEN, CHECK operation, condition
- Flight Control Locks – REMOVE
- Fuel Tank – CHECK FUEL LEVEL on Mechanical Fuel Gauge (check with aircraft on a level surface)
- Confirm fuel type - Check fuel approval (See 2.8 Fuel Limitations) using OAT to minimize vapor lock.
- Master Switch – ON
- Avionics – ON
- Stall Warning Vane – ACTUATE (IF INSTALLED)
- Stall Warning Horn – ON (Headset/EFIS) (IF INSTALLED)
- Alt Air Valve – PUSH DOWN – OFF (IF INSTALLED)
- Fuel Shut-Off Valve (912 ULS Only) – PUSH DOWN – ON

WARNING

During high ambient temperature conditions, run the fuel pump for 5 mins to flush the fuel lines and minimize the potential for vapor lock.

- Lights / Strobes – CHECK then OFF
- Avionics – OFF
- Master Switch – OFF
- ELT – OFF
- Baggage – RESTRAINED
- Foreign or Misplaced Objects – CHECK

Left Main Landing Gear

- Tire – CONDITION, proper inflation 25 psi
- Brake – CHECK condition, no leakage
- Axle Nut – CHECK cotter pin installation
- Wheel Bearings – SHAKE WHEEL – CHECK
- Wheel Chocks – REMOVE

Left Wing

- Wing – CONDITION
- Wing Hand Hold – CHECK no free movement*
- Tie-Down – REMOVE (can remove eyebolt too)
- AOA Static Port – check for obstructions
- PITOT Tube – check for obstructions
- Flaperon – CHECK condition, freedom of movement
- Flaperon Hinge Brackets – BOLTS – CHECK

***WARNING**

When applying Fore and Aft force check for play at the rear spar junction. This is usually discovered by hearing a clicking noise.

If this is the case, refer to the Maintenance Manual for corrective action.

Excessive fore and aft play in the left wing may also render the EFIS AOA indications inaccurate.

Fuselage (Left Side)

- Flaperon Controls – CONNECTED
- Fuel Sample – CHECK for water or sediment contamination.
- Static Port – CLEAN & OPEN

Empennage

- Vertical Stabilizer – CHECK condition
- Stabilator – CHECK condition, freedom of movement
- Anti-Servo Tab – CHECK condition, proper attachment
- Rudder – CHECK condition, proper attachment, freedom of movement
- Tie-Down – REMOVE

Fuselage (Right Side)

- Static Port – CLEAN & OPEN
- Comm. Antenna – CHECK condition & security
- Fuel Vent Lines – CLEAR
- Fuel Cap – SECURE
- Flaperon Controls – CONNECTED

Right Wing

- Flaperon – CHECK condition, freedom of movement
- Flaperon Hinge Brackets – BOLTS – CHECK
- Wing Hand Hold – CHECK no free movement*
- Wing – CONDITION
- Tie-Down – REMOVE (can remove eyebolt too)

Right Main Landing Gear

- Tire – CONDITION, proper inflation 25 psi
- Brake – CHECK condition, no leakage
- Axle Nut – CHECK cotter pin installation
- Wheel Bearings – SHAKE WHEEL – CHECK
- Wheel Chocks – REMOVE

Nose Section

- Transponder Antenna – CHECK condition & security
- Muffler – CHECK condition, security of attachment
- Coolant – LEVEL CHECK
- Alt Air Door – CHECK CLOSED

Continued on next page

- Engine Oil – CHECK quantity, color, and clarity

WARNING

Before performing the engine oil check procedure, make sure the master and both lane/ignition switches are in the OFF position.

1. Remove oil cap from oil tank and place cap in holder on oil door
2. Turn propeller by hand in direction of propeller rotation several times to pump oil from engine into oil tank
3. A gurgling sound will be heard
4. Check oil level on stick
5. Return cap to oil tank and secure

ALTERNATIVE TO STEP 2:

- Remove oil cap from oil tank and place cap in holder on oil door
- OIL minimum quantity at or above tip of dipstick
- MASTER SWITCH – ON
- Lane/Ignition Switches – BOTH OFF
- Use the start key to turn the propeller for 10 seconds
- MASTER SWITCH – OFF
- Proceed to Step 3

Nose Section (Continued)

- Nose Landing Gear – CHECK attachment to fuselage
- Nose Tire – CONDITION, proper inflation 22 psi
- Tow Bar – Disconnected and stowed
- Wheel Chocks – REMOVE
- Cowling – CHECK condition, all screws installed
- Air Inlets – CHECK all unobstructed
- Propeller and Spinner – CHECK condition, security
- Pitot – CLEAN & OPEN (IF INSTALLED)
- Oil & Coolant Radiators – CHECK unobstructed
- Oil & Coolant Radiator Blockoffs – INSTALL or REMOVE as required by ambient conditions.

4.4 PRE-START

- Passenger Briefing – PERFORM**
- Baggage – RESTRAINED
- Safety Belts – FASTENED & SNUG
- Canopy – LATCHED
- Alt Air Valve – PUSH DOWN – OFF (IF INSTALLED)
- Fuel Shut-Off Valve (912 ULS Only) – PUSH DOWN – ON
- Throttle – CHECK FRICTION
- Master Switch – ON
- Fuses – CHECK none illuminated
- Strobe Lights – ON (Omit until after start if battery low)

**14 CFR 91.327(e) Each person operating an aircraft issued a special airworthiness certificate in the light-sport category must advise each person carried of the special nature of the aircraft and that the aircraft does not meet the airworthiness requirements for an aircraft issued a standard airworthiness certificate.

**14 CFR 91.107 – requires pilot to brief passengers on the use of seat belts/harnesses.

4.5 ENGINE START

CAUTION

Do not start engine when oil temp is below -13° F / -20 ° C or ambient temp above 120 ° F / 50 ° C

- Brakes – TEST & HOLD
- Fuel Pump 1 Switch (912 iS Only) – ON
- Fuel Pump 2 Switch (912 iS Only) – OFF
- Lane A & B (or Ignition Switches) – BOTH ON
- Lane A & B Fault Indicator Lights (912 iS Only) – Illuminate and extinguish after 3 seconds
- (If, after 3 seconds, a light flashes, illuminates, or fails to illuminate, abort start and refer to 3.2.1 “Lane Fault Indications”)
- Fuel Pressure – CHECK > 0
- Throttle Position (Cold) – 50% +/-5%
- Throttle Position (Warm) – 35% +5%
- Propeller – CLEAR
- Ignition Key – ENGAGE (until RPM > 1,500 RPM) (10 second max activation followed by 2 minute cooling period)
- Throttle – REDUCE as required.
- Oil pressure – CHECK 12 psi within 10 seconds or shutdown engine
- Throttle (912 iS Only) – Above 2,500 RPM for 5 seconds.
- Engine Gauges (912 iS Only) – CHECK SHIFT GEN B to GEN A
- Ammeter – CHECK FOR CHARGING
- Avionics Switch – ON
- Fuel Pump 2 Switch (912 iS Only) – ON

NOTE

If one Lane A & B fault indicator light turns on or flashes after engine start, perform a “LANE and IGNITION Check”. See 4.7.

If both Lane A & B fault indicator lights turn on after engine start, proceed to 4.17 “Shutdown”. Refer to 3.2.1 “Lane Fault Indications”.

- Throttle =< 2,500 RPM until oil reaches 120° F (50° C)

4.6 TAXIING

Taxi operations during high winds require the conventional use of the flight controls. With a head wind or quartering head wind, place the control stick full aft and into the wind. With a tail wind or quartering tail wind, use the opposite procedures. The use of the wheel brakes in conjunction with the rudder will assist the pilot in maintaining directional control.

- Engine Gauges – CHECK
- Flight Instruments – VERIFY proper indications
- Parking Brake – RELEASE (IF INSTALLED)
- Brakes – RELEASE
- Taxi Throttle – 1,800–2,500 RPM until oil temp reaches 120° F (50° C)

NOTE

Higher RPM will heat the oil more rapidly on cool days.

Especially on hot days CHT can rise significantly if RPM is low. Increase RPM to 3,500 and above to increase airflow through the radiator and reduce the coolant temperature.

4.7 BEFORE TAKEOFF RUN UP

- Brakes – HOLD
- Flight Controls – FREE & CORRECT
- Flight Instruments – CHECK – SET
- Fuel Shut-Off Valve (912 ULS Only) – CHECK DOWN – ON
- Fuel Quantity Indication – CHECK
- Trim – SET for takeoff
- Canopy – LATCHED
- Minimum oil temp 120° F (50° C)
- Control Stick – FULL AFT

LANE and IGNITION Check (912 iS Only)

- Throttle - MAX (verify smooth operation with RPM at or above 5,000)
- Throttle – 4,000 RPM
- Lane A – OFF (Max drop 180 RPM)
- Lane A – ON
- Lane Fault Light – Wait to extinguish
- Lane B – OFF (Max drop 180 RPM)
- Lane B – ON
- Throttle – 2,000 RPM
- Engine Gauges – CHECK

LANE and IGNITION Check (912 ULS Only)

- Throttle – 4,000 RPM
- Ignition A – OFF (Max drop 300 RPM)
- Ignition – ON
- Ignition B – OFF (Max drop 300 RPM)
- Ignition B – ON
- Difference between A & B drops less than 115 RPM
- Throttle – 2,000 RPM
- Engine Gauges – CHECK

FUEL PUMP Check (912 iS Only)

- Fuel Pump 1 – ON
- Fuel Pump 2 – OFF wait 5 sec check fuel pressure 40.6 to 55.1 psi
- Fuel Pump 2 – ON
- Fuel Pump 1 – OFF wait 5 sec check fuel pressure 40.6 to 55.1 psi
- Fuel Pump 1 – ON

- Fuses – CHECK none illuminated
- Seat Belt, Pilot and Passenger – FASTENED & SNUG
- Takeoff Briefing and Abort Plan – REVIEW
- Brakes – RELEASE

4.8 TAKE-OFF (Normal)

- Control Stick – Halfway between neutral and aft
- Throttle – Smoothly FULL OPEN
- Stabilator Control – Hold back pressure on control to RAISE NOSE just clear of ground, release as needed.
- Lift Off – 50-55 KIAS
- Climb – 75 KIAS (V_y)
- Flaps – UP
- Trim – AS REQUIRED to hold desired airspeed

During crosswind conditions, place the control stick into the wind (up wind aileron UP) and raise the nose just clear of the ground as early in the take-off roll as possible to improve rudder authority and prevent drifting or premature lift-off. When taking off with a left crosswind and full power, right rudder is a limiting factor.

4.9 TAKE-OFF (Obstacle)

During an obstacle take-off, use the normal take-off procedures with the following exceptions:

- Flaps – HALF
- Brakes – HOLD until application of full power
- Lift-Off – 50 to 55 KIAS
- Climb – 60 KIAS (V_x) until clear of obstacle

4.10 TAKE-OFF (Soft Field)

For soft field take-off, use the normal take-off procedures with the following exceptions:

- Flaps – HALF
- Stabilator – hold back pressure on control to RAISE NOSE slightly higher than used for a normal takeoff.
- After Lift-Off – LEVEL FLIGHT to obtain safe margin of airspeed prior to climb (V_x or V_y)

WARNING

The aircraft will lift-off at very low IAS but continued climb-out below 60 KIAS immediately after take-off is not recommended.

4.11 CLIMB

- Throttle – FULL
5,800 RPM Max 5 minutes
5,500 RPM Max Continuous
- Airspeed –
Best Rate 75 KIAS
Flaps – UP
Best Angle 60 KIAS
Flaps – HALF
Cruise-Climb 85 KIAS
Flaps – UP
- Engine Gauges – CHECK
- Trim – AS REQUIRED

4.12 CRUISE

- Flaps – CHECK – UP
- Throttle – SET RPM to cruise power (5,500 RPM Max)
- Trim – AS REQUIRED
- Engine Gauges – CHECK

Refer to 7.2.1 regarding fuel consumption while in ECO mode or POWER mode.

4.13 DESCENT & APPROACH

- Throttle – REDUCE
- Flight Instruments – ADJUST
- Airspeed – AS DESIRED
- Engine Gauges – MONITOR
- Flaps – UP (above 82 KIAS)
AS DESIRED (below 82 KIAS)

The descent should be made with enough power to maintain cylinder head and oil temperatures in the green. If possible, avoid windmilling the engine with the propeller by reducing airspeed or increasing power.

When planning a descent from cruise altitude to the airport traffic pattern, use time to destination to calculate a realistic and comfortable rate (500 ft/minute).

When available, use the vertical navigation (VNAV) function of the EFIS to perform a stable descent if terrain, airspace, and/or weather permit.

4.14 LANDING

- Seat Belt – Pilot and Passenger – FASTENED & SNUG
- Brakes – CHECK firm then release
- Lane A & B (or Ignition Switches) – BOTH ON
- Fuel Pump Switches (912 iS Only) – BOTH ON
- Lights – ON STEADY
- Flaps – AS DESIRED (below 82 KIAS)
- Airspeed – 55-60 KIAS
- Trim – AS REQUIRED
- Throttle – AS DESIRED to control rate of descent
- Touchdown – MAIN WHEELS FIRST
- After Touch Down –
 - Stabilator Control – Increase to FULL AFT as speed decreases
 - Brake as Required

The best technique for use on soft or rough fields is to fly the landing approach at minimum speed carrying power into the landing flare and using an extreme nose high landing attitude so as to touch down with minimum airspeed.

When landing under gusty and or crosswind conditions do not use flaps.

During gusty wind conditions, fly the landing approach at approximately 5 kts above normal and touch down with the nose slightly lower than for a normal landing.

Crosswind approaches can best be accomplished by using the wing down top rudder method touching first on the down wing side main wheel, followed by the other main wheel, and finally lowering the nose wheel all the while keeping the stick into the wind.

4.15 LANDING (Obstacle)

Use normal landing procedures and in addition:

- Flaps – FULL DOWN
- Airspeed – 55 KIAS
- Throttle – AS REQUIRED to control rate of descent
- Slip aircraft as necessary to increase rate of descent

WARNING

A relatively high rate of descent is possible in this configuration when at full gross weight and the throttle closed.

If airspeed is allowed to decrease below 55 KIAS, level off can only be assured with an application of power.

4.16 LANDING (Balked)

Use normal landing procedures and in addition at the time of going around:

- Throttle – FULL OPEN
- Flaps – HALF
- Airspeed –
Best Angle – 60 KIAS
Flaps – HALF until clear of obstacle, then
Best Rate – 75 KIAS
Flaps – UP

4.17 SHUTDOWN

Normal Shutdown

- NAV & Land Light Switches – OFF
- Avionics Switch – OFF
- ELT – CHECK OFF

If the following three steps are completed in the order shown the engine will shut down at as low RPM as possible and reduce wear in the gearbox.

- Throttle – 2000 RPM
Note: Turning off Lane A & B should be done in quick succession. While turning off ignitions, reduce throttle to idle.
- Parking Brake – SET (IF INSTALLED)
- Lane A & B (or Ignition Switches) – BOTH OFF
- Fuel Pump Switches (912 iS Only) – BOTH OFF
- Master Switch – OFF
- Control Locks (seat belt connected around stick and tow bar installed as a rudder lock), Chocks, & Tie-Downs – As needed

NOTE

If high winds are anticipated, the aircraft should be hangared. If the aircraft must be left out, park into the wind and use additional tie-down ropes for security. Place the flaps in the full up position and secure the control stick full aft with the lap belt.

Cold Weather Shutdown

Post-Flight Rotax 912ULS:

- Fuel Pump - ON
- Fuel Sample - CHECK until no more water or fuel/water mixture is present.
- Fuel Pump – OFF

Post-Flight Rotax 912iS:

- Let fuel settle to allow water to come out of solution.
- Fuel Sample - CHECK until no more water or fuel/water mixture is present.

Hot Weather Shutdown

To prevent vapor building in the fuel lines after shutdown in hot days

- Engine Cool Down – PERFORM engine cooling run of at least 2 minutes.
- Open the oil door
- Latch the canopy in the mid open position using the Support Plate Canopy Latch

SECTION 5

PERFORMANCE

INDEX

5.1	INFORMATION	5-1
5.2	AIRSPED CALIBRATION	5-2
5.3	STALL SPEEDS	5-2
5.4	TAKE-OFF & CLIMB PERFORMANCE	5-3
5.5	LANDING PERFORMANCE	5-7
5.6	CRUISE PERFORMANCE	5-8

5.1 INFORMATION

This data is to inform the pilot what can be expected from the aircraft in the way of performance and to assist in preflight planning.

The data has been compiled from both estimated calculations and actual flight test using average piloting techniques, with an aircraft and engine in good operating conditions. All information is corrected for standard atmospheric conditions.

5.2 AIRSPEED CALIBRATION TABLE

CALIBRATED AIRSPEED	INDICATED AIRSPEED
45	45*
50	50
55	55
60	60
65	65
70	70
75	75
80	80
85	85
90	90
100	100
110	110
120	120
130	130
140	140
150	150

NOTE

The indicated airspeed may vary by the instrument accuracy requirements of SAE AS8002A.

* As the aircraft approaches a stall, calibrated airspeed will continue to decrease while the indicated airspeed stabilizes at a constant value. In some configurations this difference may reach up to 5 kts above calibrated airspeed due to disturbed flow over the static ports.

5.3 STALL SPEEDS TABLE (KIAS)

FLAP POSITION	GROSS WEIGHT			
	1050		1320	
	KIAS	KCAS	KIAS	KCAS
UP	45	41	50	45
1/2 DOWN	43	39	48	44
FULL DOWN	41	37	45	41

5.4.1 TAKE-OFF & CLIMB PERFORMANCE @ 1320 lb (912iS)

PRESS ALTITUDE (FT)	TEMP (°F)	TAKE-OFF DISTANCE (FT)		MAX RATE OF CLIMB (FT/MIN)
		GROUND ROLL	50 FT OBSTCL	
SEA LEVEL	0	589	1,091	1,156
	20	641	1,188	1,069
	40	696	1,291	985
	60	750	1,397	906
	80	812	1,519	831
	100	873	1,647	758
2,000	0	681	1,263	1,007
	20	742	1,380	921
	40	805	1,505	839
	60	871	1,642	761
	80	939	1,790	687
	100	1,010	1,954	616
4,000	0	790	1,474	858
	20	860	1,619	774
	40	933	1,777	693
	60	1,010	1,952	617
	80	1,089	2,150	544
	100	1,171	2,379	474
6,000	0	917	1,742	710
	20	999	1,927	627
	40	1,084	2,138	548
	60	1,173	2,384	473
	80	1,265	2,680	401
	100	1,360	3,060	333
8,000	0	1,068	2,097	562
	20	1,163	2,355	481
	40	1,262	2,671	403
	60	1,365	3,082	330
	80	1,472	3,678	259
	100	1,583	4,720	192

5.4.2 TAKE-OFF & CLIMB PERFORMANCE @1320lb (912ULS)

PRESS ALTITUDE (FT)	TEMP (°F)	TAKE-OFF DISTANCE (FT)		MAX RATE OF CLIMB (FT/MIN)
		GROUND ROLL	50 FT OBSTCL	
SEA LEVEL	0	589	1,091	1,156
	20	641	1,188	1,069
	40	696	1,291	985
	60	750	1,397	906
	80	812	1,519	831
	100	873	1,647	758
2,000	0	681	1,263	1,007
	20	742	1,380	921
	40	805	1,505	839
	60	871	1,642	761
	80	939	1,790	687
	100	1,010	1,954	616
4,000	0	790	1,474	858
	20	860	1,619	774
	40	933	1,777	693
	60	1,010	1,952	617
	80	1,089	2,150	544
	100	1,171	2,379	474
6,000	0	917	1,742	710
	20	999	1,927	627
	40	1,084	2,138	548
	60	1,173	2,384	473
	80	1,265	2,680	401
	100	1,360	3,060	333
8,000	0	1,068	2,097	562
	20	1,163	2,355	481
	40	1,262	2,671	403
	60	1,365	3,082	330
	80	1,472	3,678	259
	100	1,583	4,720	192

5.4.3 TAKE-OFF & CLIMB PERFORMANCE @ 1050 lb (912iS)

PRESS ALTITUDE (FT)	TEMP (°F)	TAKE-OFF DISTANCE (FT)		MAX RATE OF CLIMB (FT/MIN)
		GROUND ROLL	50 FT OBSTCL	
SEA LEVEL	0	471	951	1,455
	20	513	1,034	1,345
	40	557	1,122	1,241
	60	600	1,212	1,141
	80	650	1,314	1,046
	100	699	1,421	956
2,000	0	545	1,098	1,268
	20	594	1,197	1,160
	40	644	1,303	1,057
	60	697	1,416	959
	80	751	1,539	865
	100	808	1,673	776
4,000	0	632	1,277	1,081
	20	688	1,397	975
	40	747	1,528	874
	60	808	1,672	777
	80	871	1,830	686
	100	937	2,008	598
6,000	0	734	1,499	895
	20	799	1,651	790
	40	867	1,821	691
	60	938	2,012	596
	80	1,012	2,233	506
	100	1,088	2,497	420
8,000	0	854	1,787	709
	20	930	1,990	606
	40	1,010	2,226	509
	60	1,092	2,511	416
	80	1,178	2,877	327
	100	1,267	3,387	243

5.4.4 TAKE-OFF & CLIMB PERFORMANCE @ 1050 lb (912ULS)

PRESS ALTITUDE (FT)	TEMP (°F)	TAKE-OFF DISTANCE (FT)		MAX RATE OF CLIMB (FT/MIN)
		GROUND ROLL	50 FT OBSTCL	
SEA LEVEL	0	471	951	1,455
	20	513	1,034	1,345
	40	557	1,122	1,241
	60	600	1,212	1,141
	80	650	1,314	1,046
	100	699	1,421	956
2,000	0	545	1,098	1,268
	20	594	1,197	1,160
	40	644	1,303	1,057
	60	697	1,416	959
	80	751	1,539	865
	100	808	1,673	776
4,000	0	632	1,277	1,081
	20	688	1,397	975
	40	747	1,528	874
	60	808	1,672	777
	80	871	1,830	686
	100	937	2,008	598
6,000	0	734	1,499	895
	20	799	1,651	790
	40	867	1,821	691
	60	938	2,012	596
	80	1,012	2,233	506
	100	1,088	2,497	420
8,000	0	854	1,787	709
	20	930	1,990	606
	40	1,010	2,226	509
	60	1,092	2,511	416
	80	1,178	2,877	327
	100	1,267	3,387	243

5.5 LANDING PERFORMANCE* @ 1320 lb

PRESSURE ALTITUDE (FT)	TEMP (°F)	LANDING DISTANCE (FT)	
		GROUND ROLL	50 FT OBSTCL
SEA LEVEL	0	475	1,449
	20	494	1,469
	40	513	1,488
	60	532	1,508
	80	551	1,528
	100	570	1,548
2,000	0	508	1,483
	20	529	1,504
	40	549	1,526
	60	569	1,547
	80	590	1,568
	100	610	1,589
4,000	0	544	1,521
	20	566	1,543
	40	588	1,566
	60	610	1,589
	80	631	1,612
	100	653	1,634
6,000	0	583	1,561
	20	607	1,586
	40	630	1,610
	60	653	1,635
	80	677	1,659
	100	700	1,684
8,000	0	626	1,606
	20	651	1,632
	40	676	1,659
	60	701	1,685
	80	726	1,711
	100	752	1,737

*See Notes

Landing Performance Notes

- Zero wind, 55 KIAS approach speed, flaps fully extended, gross weight, dry/smooth/level pavement.
- Decrease 50 foot obstacle distances by 10% for each 15 kts of headwind.

5.6.1 CRUISE PERFORMANCE* (912 iS)

CRUISE DENSITY ALTITUDE (FT) STANDARD TEMP	RPM	TAS (KTS)	FUEL FLOW (GPH)
0 (59°F)	4,500	96	4.4
	5,000	107	5.1
	5,500	120	6.2
500 (57°F)	4,500	96	4.4
	5,000	107	5.0
	5,500	120	6.1
1,500 (54°F)	4,500	95	4.2
	5,000	106	4.8
	5,500	120	5.9
2,500 (50°F)	4,500	95	4.0
	5,000	106	4.7
	5,500	119	5.7
3,500 (47°F)	4,500	94	3.9
	5,000	105	4.5
	5,500	119	5.5
4,500 (43°F)	4,500	94	3.7
	5,000	105	4.3
	5,500	118	5.3
5,500 (39°F)	4,500	93	3.6
	5,000	104	4.2
	5,500	118	5.2
6,500 (36°F)	4,500	93	3.4
	5,000	104	4.0
	5,500	117	5.0
7,500 (32°F)	4,500	92	3.3
	5,000	103	3.8
	5,500	117	4.8
8,500 (29°F)	4,500	91	3.1
	5,000	103	3.6
	5,500	116	4.6
9,500 (25°F)	4,500	91	3.0
	5,000	102	3.5
	5,500	115	4.4
10,500 (22°F)	4,500	90	2.8
	5,000	101	3.3
	5,500	115	4.2
11,500 (18°F)	4,500	89	2.7
	5,000	100	3.1
	5,500	114	4.0
12,500 (14°F)	4,500	88	2.5
	5,000	99	3.0
	5,500	113	3.9

*See Notes

912 iS Cruise Performance Notes

- Conditions: gross weight, standard temperature (higher than standard temperature will reduce performance), recommended propeller pitch.

5.6.2 CRUISE PERFORMANCE* (912 ULS)

CRUISE DENSITY ALTITUDE (FT) STANDARD TEMP	RPM	TAS (KTS)	FUEL FLOW (GPH)
7,500 (57°F)	4,500	88	3.7
	5,000	102	4.7
	5,500	115	6.3

*See Notes

912 ULS Cruise Performance Notes

- Conditions: gross weight, standard temperature (higher than standard temperature will reduce performance), recommended propeller pitch.

THIS PAGE INTENTIONALLY LEFT BLANK

SECTION 6

WEIGHT & BALANCE & EQUIPMENT LIST

INDEX

6.1	INFORMATION	6-1
6.2	OPERATING WEIGHTS & LOADING	6-2
6.3	INSTALLED EQUIPMENT LIST	6-2
6.4	OPTIONAL EQUIPMENT LIST	6-3
6.5	SAMPLE LOADING PROBLEM	6-4
6.6	YOUR AIRPLANE	6-5
	FLIGHT ENVELOPE – ARM	6-6
	FLIGHT ENVELOPE – MOMENT	6-7

6.1 INFORMATION

It is the pilot's responsibility to ensure that the aircraft is loaded properly and within the weight and balance limitations. All flight performance, procedures and characteristics are based on this prerequisite.

The actual licensed empty weight and CG of a specific aircraft can be found on the Weight and Balance Form which is a permanent part of the aircraft's file and onboard documentation. All additional changes to the aircraft's empty weight and CG after the time of manufacture must also be attached to or indicated. From this information and the following instructions, the pilot can easily determine the useful load and proper loading distribution for the aircraft.

For further information see RV-12iS FTS Section III Pre-Flight Planning, Basics of Loading the RV-12iS.

6.2 OPERATING WEIGHTS & LOADING

<u>Category</u>	<u>Max Weight</u>	<u>Center of Gravity Range</u>
Light Sport	1320 lb	80.49" to 85.39" (18.4 to 27% Chord)

NOTE

All measurements are aft of the datum line which is 70 inches forward of the wing leading edge.

Baggage 75 lb maximum (dependent on the c.g. limits)

6.3 INSTALLED EQUIPMENT LIST

For Installed Equipment List see the Maintenance Manual.

6.5 SAMPLE LOADING PROBLEM

ITEM	ARM (IN.) (LIMITS 80.49-85.39)	SAMPLE AIRPLANE	
		WEIGHT (LB)	MOMENT (IN-LB)
EMPTY WEIGHT WITH OIL & COOLANT	81.79	785	64,197
PILOT	78.85	190	14,982
PASSENGER	78.85	190	14,982
BAGGAGE	114.42*	35	4005
FUEL (6 LB/GAL)	100.83	120	12,100
TAKEOFF WEIGHT & MOMENT	83.48**	1,320	110,194

*Center of baggage area

****CG = TOTAL MOMENT / TOTAL WEIGHT**

6.6 YOUR AIRPLANE

ITEM	ARM (IN.) (LIMITS 80.49- 85.39)	WEIGHT (LB)	MOMENT (IN-LB)
EMPTY WEIGHT WITH OIL & COOLANT			
PILOT	78.85		
PASSENGER	78.85		
BAGGAGE	114.42		
FUEL (6 LB/GAL)	100.83		
TAKEOFF WEIGHT & MOMENT			

$$\text{CG} = \text{TOTAL MOMENT} / \text{TOTAL WEIGHT}$$

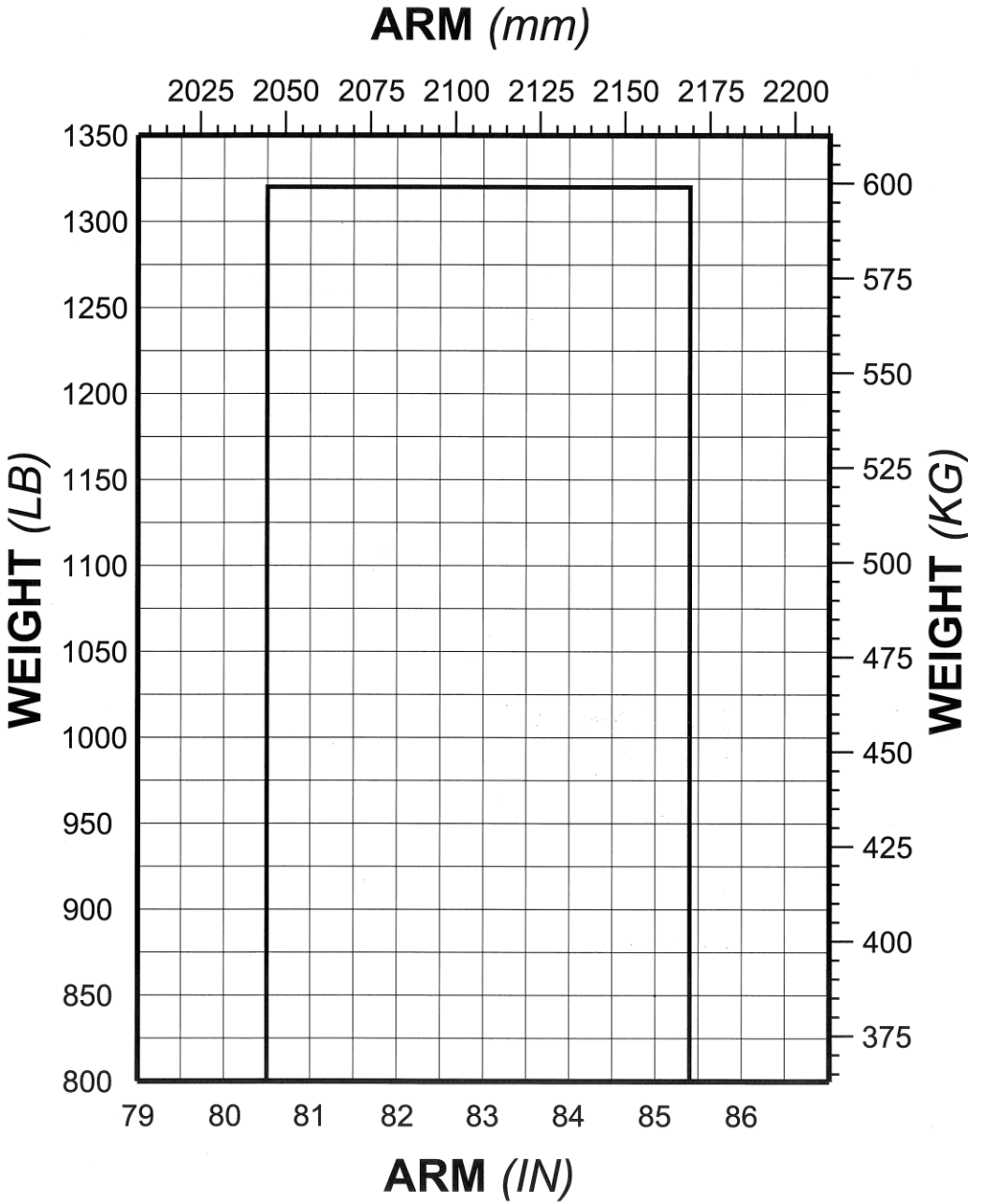

FIGURE 6-1 FLIGHT ENVELOPE - ARM
Minimum Weight varies depending on the empty weight of the aircraft

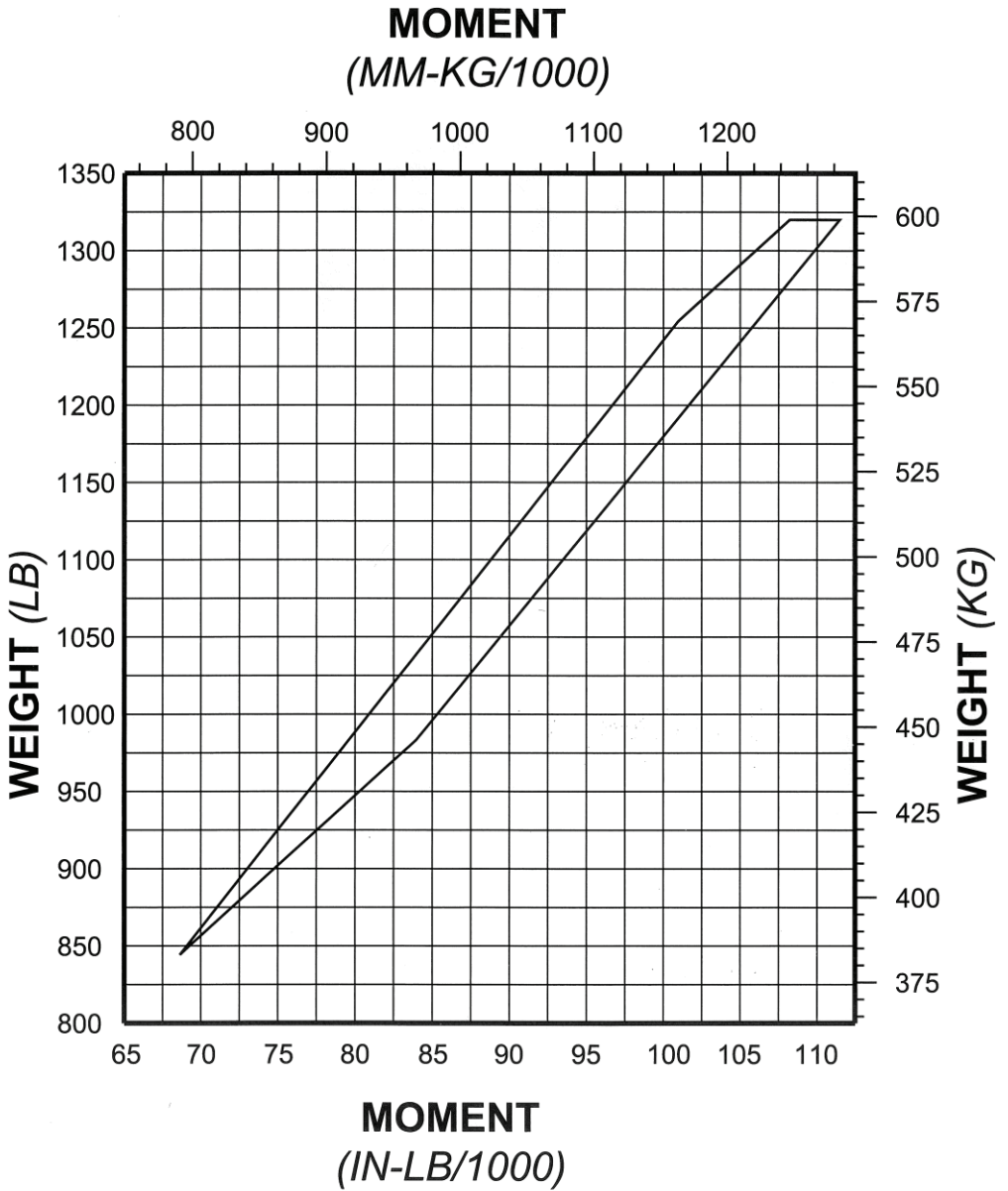

FIGURE 6-2 FLIGHT ENVELOPE - MOMENT
Minimum Weight varies depending on the empty weight of the aircraft.

THIS PAGE INTENTIONALLY LEFT BLANK

SECTION 7

DESCRIPTION OF AIRPLANE & SYSTEMS

INDEX

7.1	GENERAL DESCRIPTION	7-2
7.2	POWERPLANT SUMMARY	7-2
	7.2.1 ECO MODE AND POWER MODE	7-2
7.3	AIRCRAFT SPECIFICATIONS	7-3
7.4	DIAGRAMS	7-4
7.6	INSTRUMENT PANEL	7-6
7.7	ELECTRICAL SYSTEM	7-10
	7.7.1 SUMMARY	7-10
	7.7.2 ROTAX 912 iS GENERATOR TRANSITION	7-10
	7.7.3 FLAP SWITCH	7-10
	7.7.4 COCKPIT LIGHTING	7-10
	7.7.5 ELECTRICAL SCHEMATICS	7-10
7.8	FUEL SYSTEM	7-15
7.9	EMERGENCY EQUIPMENT	7-16

7.1 GENERAL DESCRIPTION

Airframe

The RV-12iS is an all metal, two place, low wing, single engine fixed tricycle gear airplane designed to conform to the S-LSA category.

The fuselage is made of conventional formed sheet bulkheads, stringers and skin. (Semi-monocoque)

A major item of the fuselage is the center section bulkhead that support the loads of each wing spar and main landing gear.

The removeable constant chord wings are built around a main spar that connects to the center section bulkhead.

The empennage consists of a conventional fin, rudder and a stabilator/anti servo tab.

Flight Controls

The full span ailerons and flaps are combined into one unit called flaperons. An internal mechanical mixer allows the ailerons, via torque rods, to “droop” performing the function of flaps.

The stabilator and rudder are connected to the controls by pull-pull cables.

The trim tab is driven by a DC motor.

Flight Instruments

The RV-12iS instrument panel employs an electronic flight instrument system (EFIS)s display unit. All flight, navigation and engine parameters data are displayed in one screen with an optional second screen.

7.2 POWERPLANT SUMMARY

The RV-12iS is powered by a Rotax 912 iS fuel injected engine or Rotax 912 ULS carbureted series, four cylinder, horizontally opposed, air cooled (with liquid cooled cylinder heads), rated at 100 hp/73.5 kW @ 5,800 RPM. Power to the dual spark plugs is provided by two independent engine computer units for Rotax 912iS and two independent Electronic Ignition boxes for Rotax 912US. The Rotax 912 iS engine is furnished with a starter, two generators, and two external rectifier-regulators. The Rotax 912ULS engine is furnished with a starter, single generator and an external rectifier regulator.

The propeller is a Sensenich model 2A0R5R70E two blade or optional 3Y0R5 C70MY three blade, composite, fixed ground adjustable pitch with a 70 inch/177.8 cm diameter.

Engine Description

Make	Rotax 912 iS or Rotax 912ULS
Displacement	1352 cc
Ignition	Rotax 912ULS Ducati Double CDI Rotax 912iS Duel Computer Driven
Rated Horsepower	
100 hp @ 5,800 RPM (5 minutes maximum)	
95 hp @ 5,500 RPM (continuous)	

Propeller

Make	Sensenich
Model	2A0R5R70E (2 Blade) 3Y0R5 C70MY (Optional 3 Blade)

Fuel

See Operating Limitations

Oil

See Aircraft Ground Handling and Servicing

7.2.1 ECO MODE AND POWER MODE

The Rotax 912 iS engine has two different modes: ECO mode and POWER mode. The mode in which the engine is currently operating is indicated on the EFIS.

The engine generates more power while in POWER mode but fuel consumption increases significantly.

POWER mode is engaged when the throttle position is advanced beyond approximately 97%.

The RV-12iS is equipped with an “eco stop” which allows the throttle position to be advanced up to approximately 97% (i.e. the upper limit of ECO mode). To use the “eco stop”, force the throttle lever to the left while advancing the throttle. The throttle’s advance will be stopped by the “eco stop”.

7.3 AIRCRAFT SPECIFICATIONS

Exterior Dimensions

Span	26 ft 9 in
Length	20 ft 7 in
Height	8 ft 4 in
Wing Area	127 ft ²

Weights

Empty Weight	775 lb (average)
Gross Weight	1320 lb

Loadings

Wing Loading	10.4 lb/ft ²
Power Loading	13.2 lb/hp

7.4 DIAGRAMS

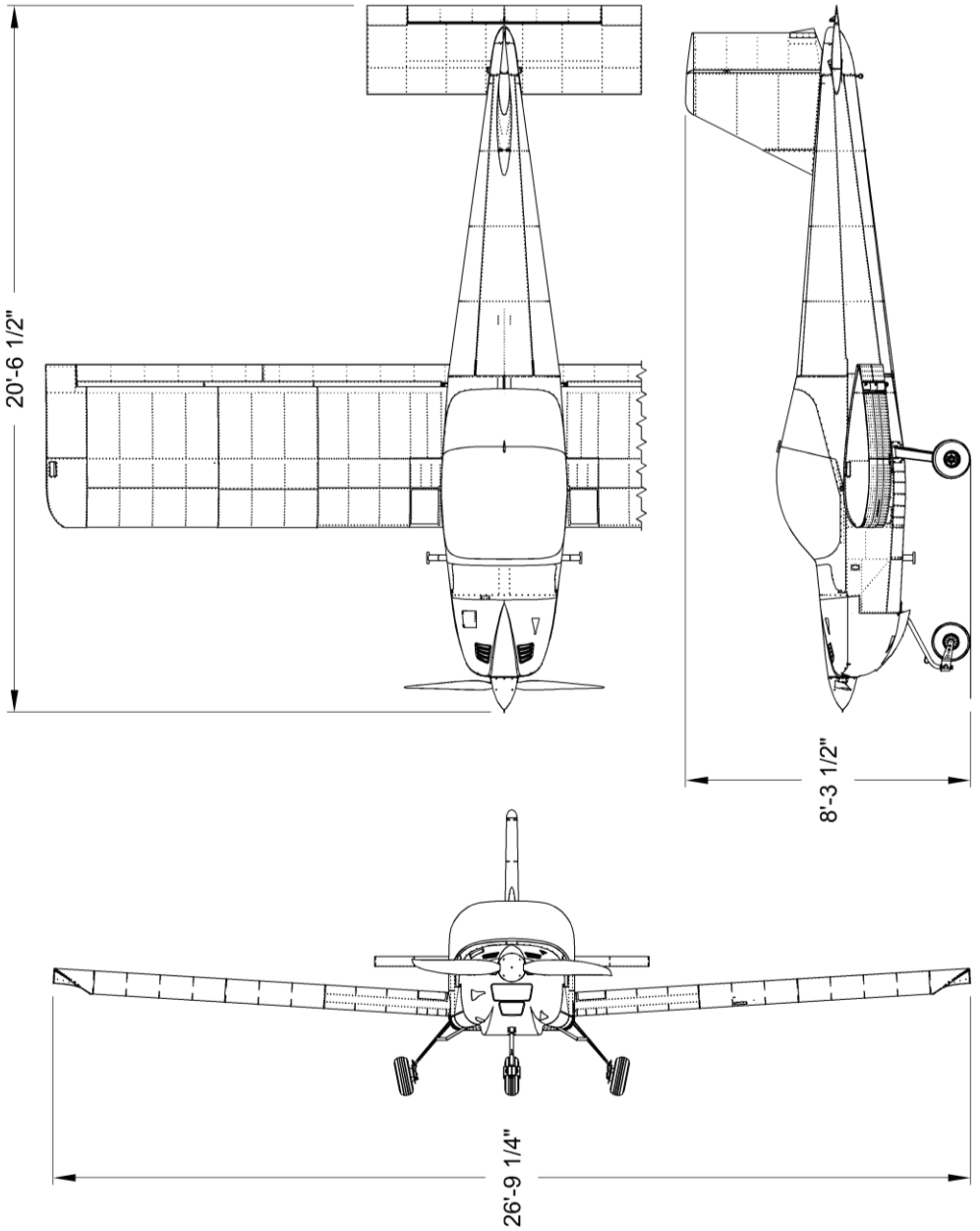

FIGURE 7-1 RV-12iS THREE VIEW

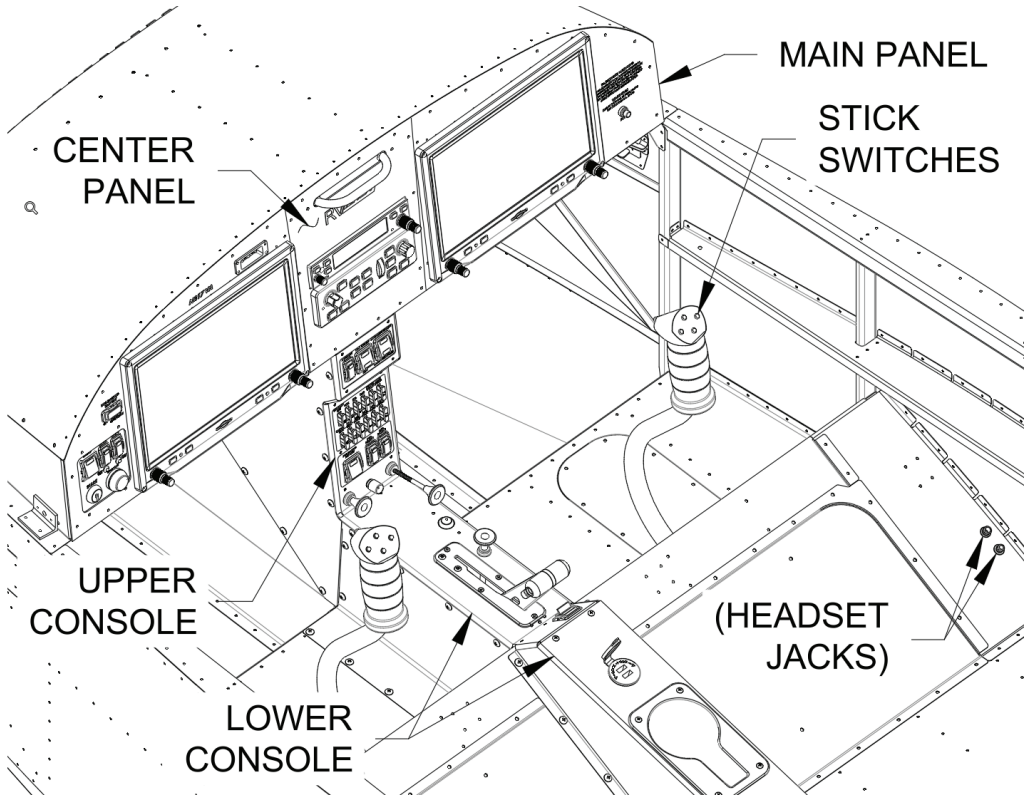

FIGURE 7-2 RV-12iS COCKPIT OVERVIEW

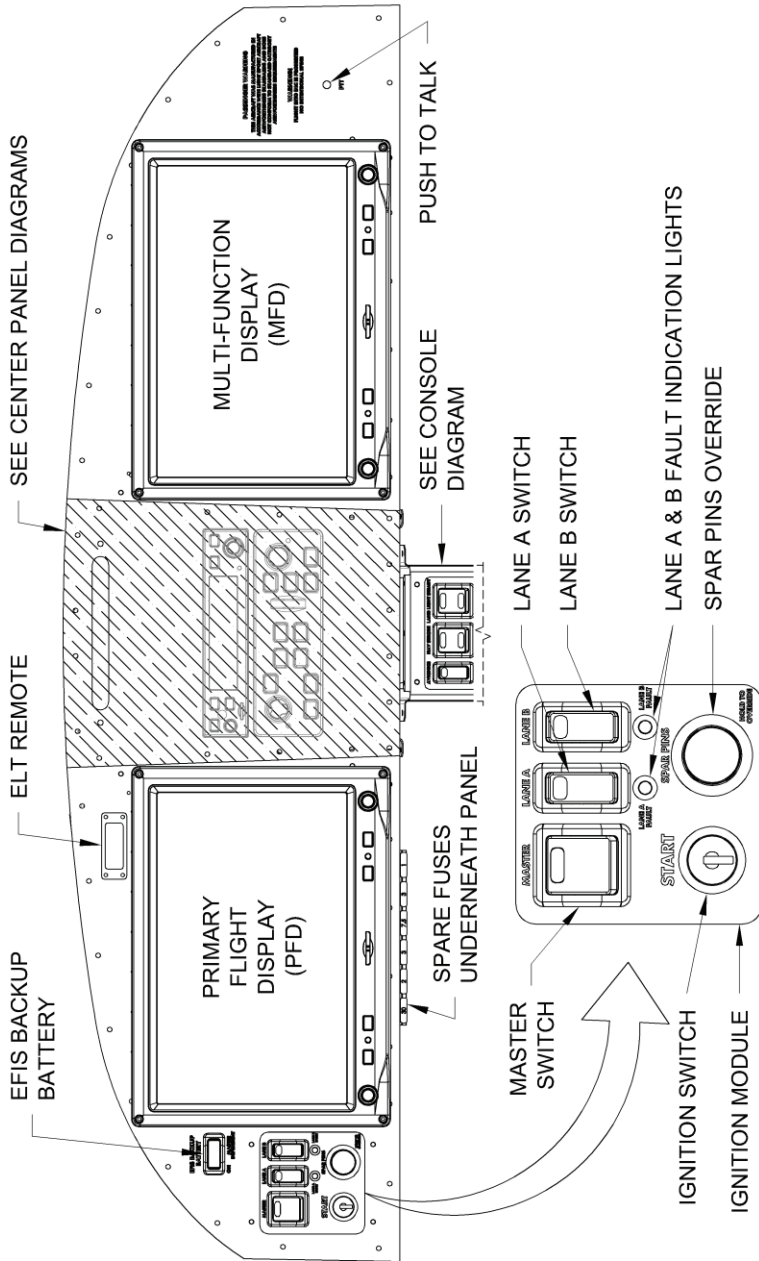
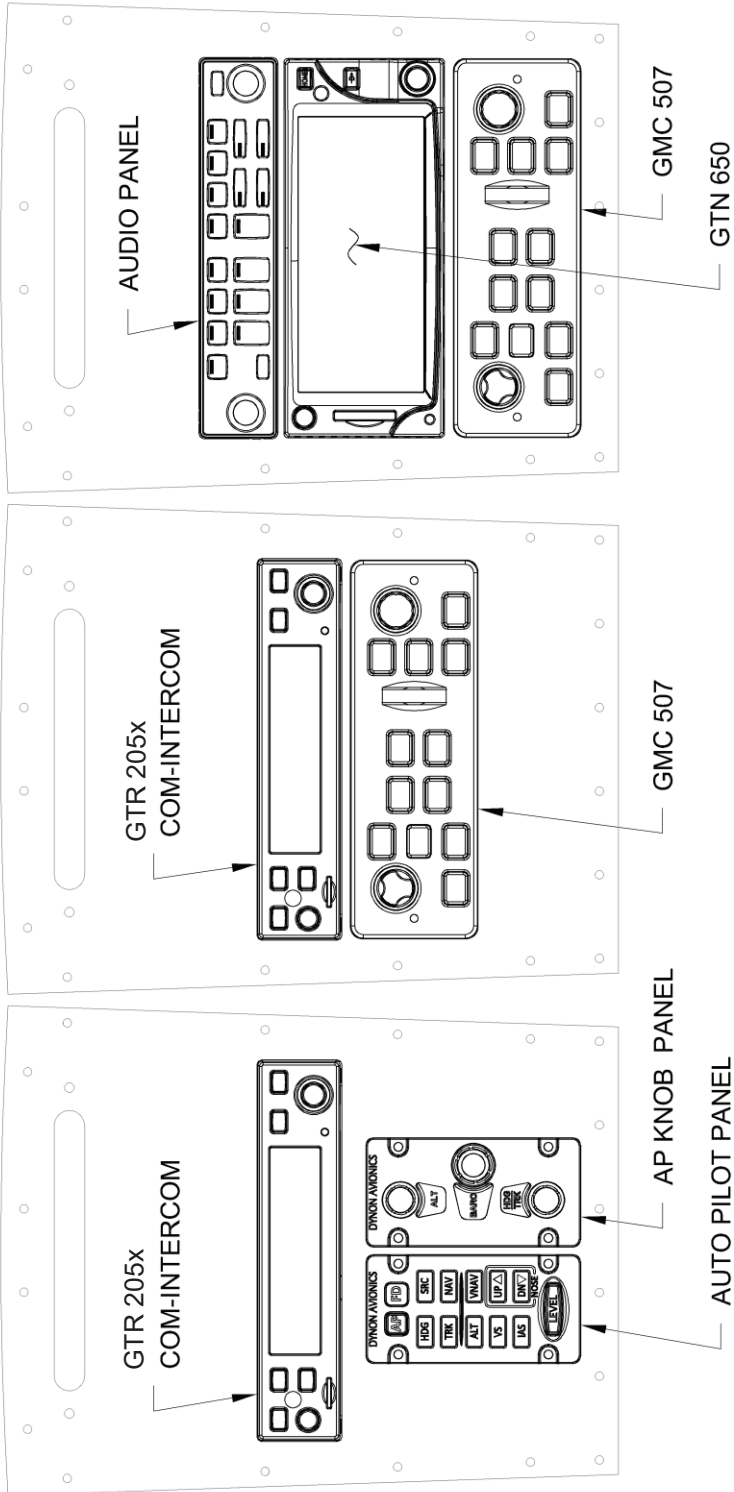

FIGURE 7-3 RV-12iS INSTRUMENT PANEL

CENTER PANEL CONFIGURATIONS



GARMIN NAV

GARMIN

SKYVIEW

FIGURE 7-4 CENTER PANEL CONFIGURATIONS

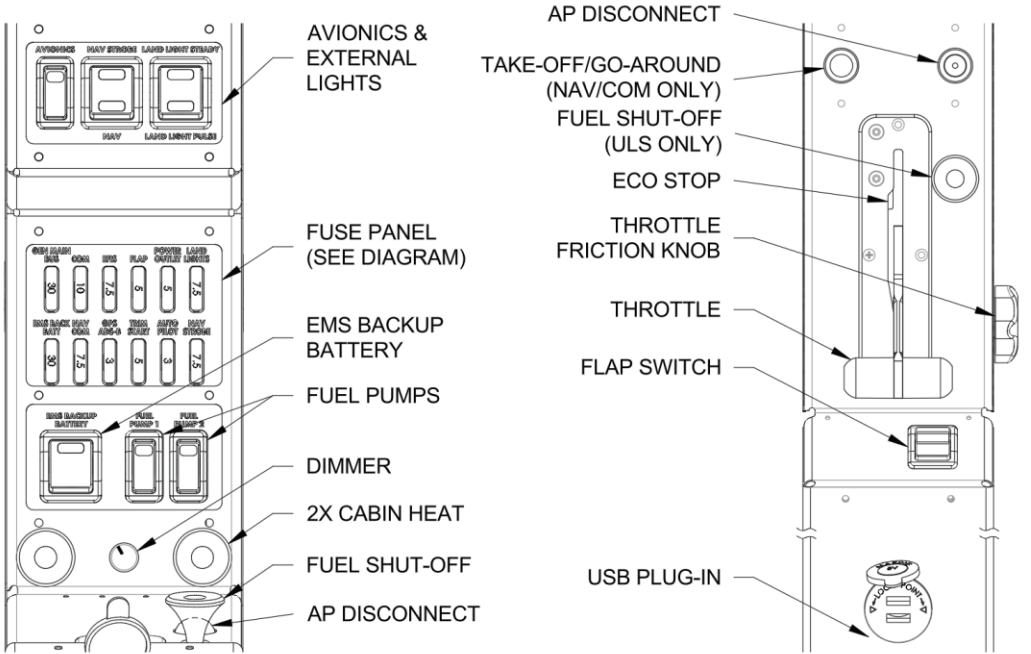

UPPER CONSOLE

LOWER CONSOLE

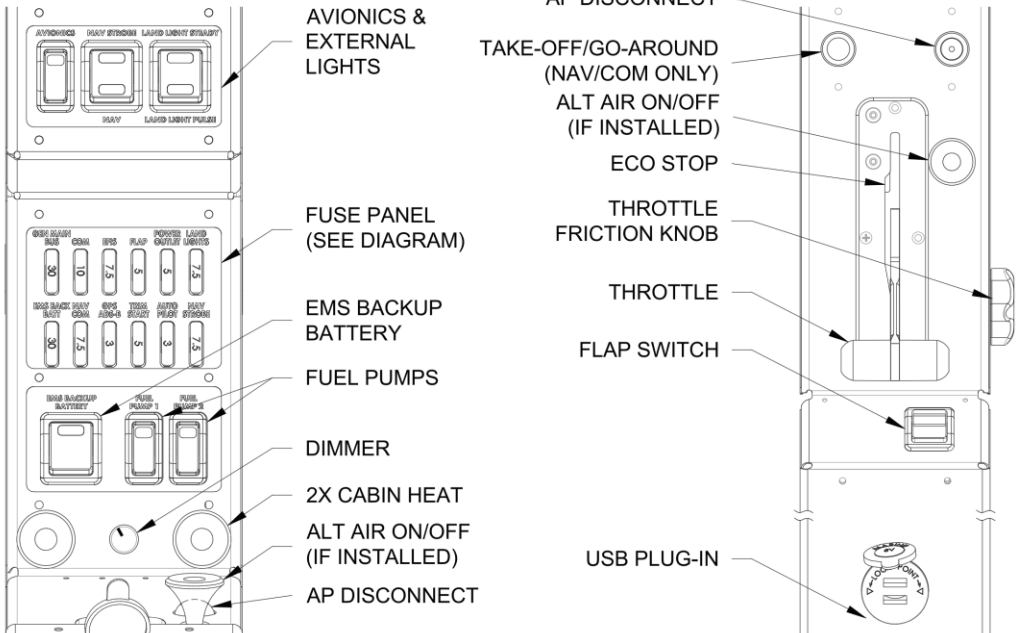

UPPER CONSOLE

LOWER CONSOLE

FIGURE 7-5 RV-12iS CONSOLES

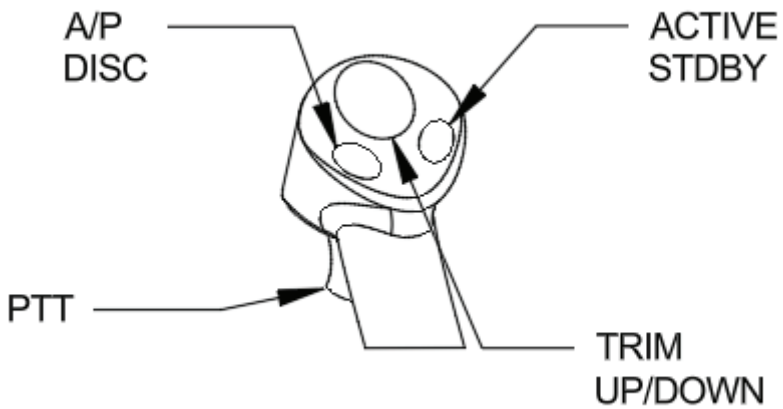
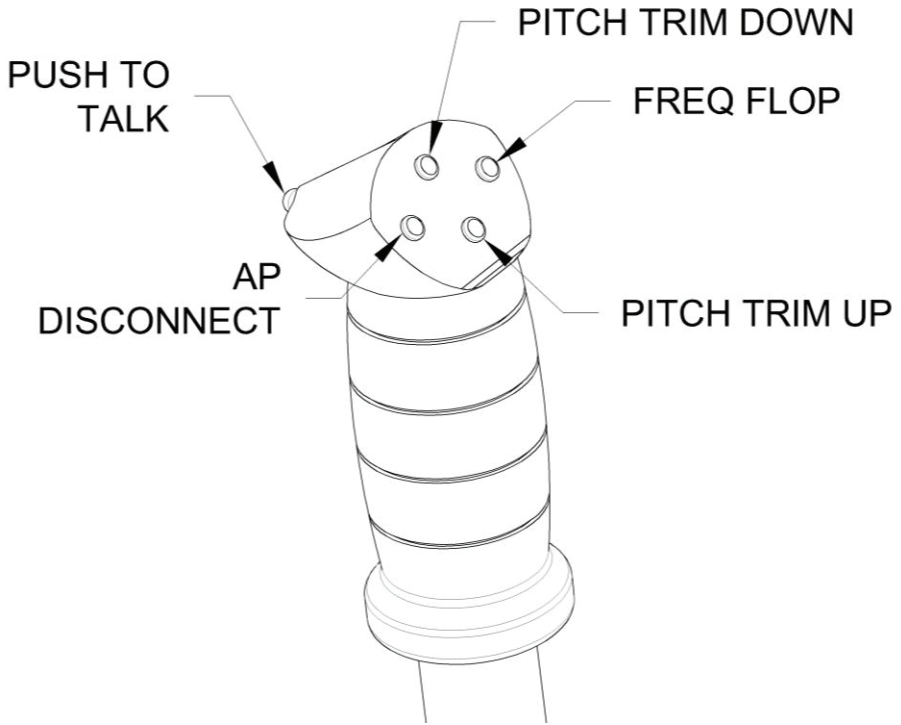

FIGURE 7-6 STICK SWITCHES

7.7 ELECTRICAL SYSTEM

7.7.1 SUMMARY

See Section VI of the FTS.

7.7.2 ROTAX 912 iS GENERATOR TRANSITION

After engine start, the Rotax 912iS generators will supply power to the engine computers but not the main bus. After the engine speed exceeds approximately 2,500 RPM for a few seconds the K1/K2 relay shown in Figure 7-7 will switch, Generator B will begin supplying power to the main bus and Generator A will supply power to the engine computers. This transition will be noted on the Gen Amp Meter (Shown on the EFIS screen)

7.7.3 FLAP SWITCH

The flap switch will latch for FLAPS UP but is momentary for FLAPS DOWN.

7.7.4 COCKPIT LIGHTING

Cockpit lighting will only turn on when the “NAV STROBE” switch is in the ON position.

7.7.5 ELECTRICAL SCHEMATICS

The following electrical schematics are a simplified overview of the electrical system provided to aid in basic operation and troubleshooting of the electrical system. A full schematic of the electrical system is available on the downloads page of the Van's Aircraft website. Also see the Rotax 912 iS or Rotax 912 ULS installation and operation manuals.

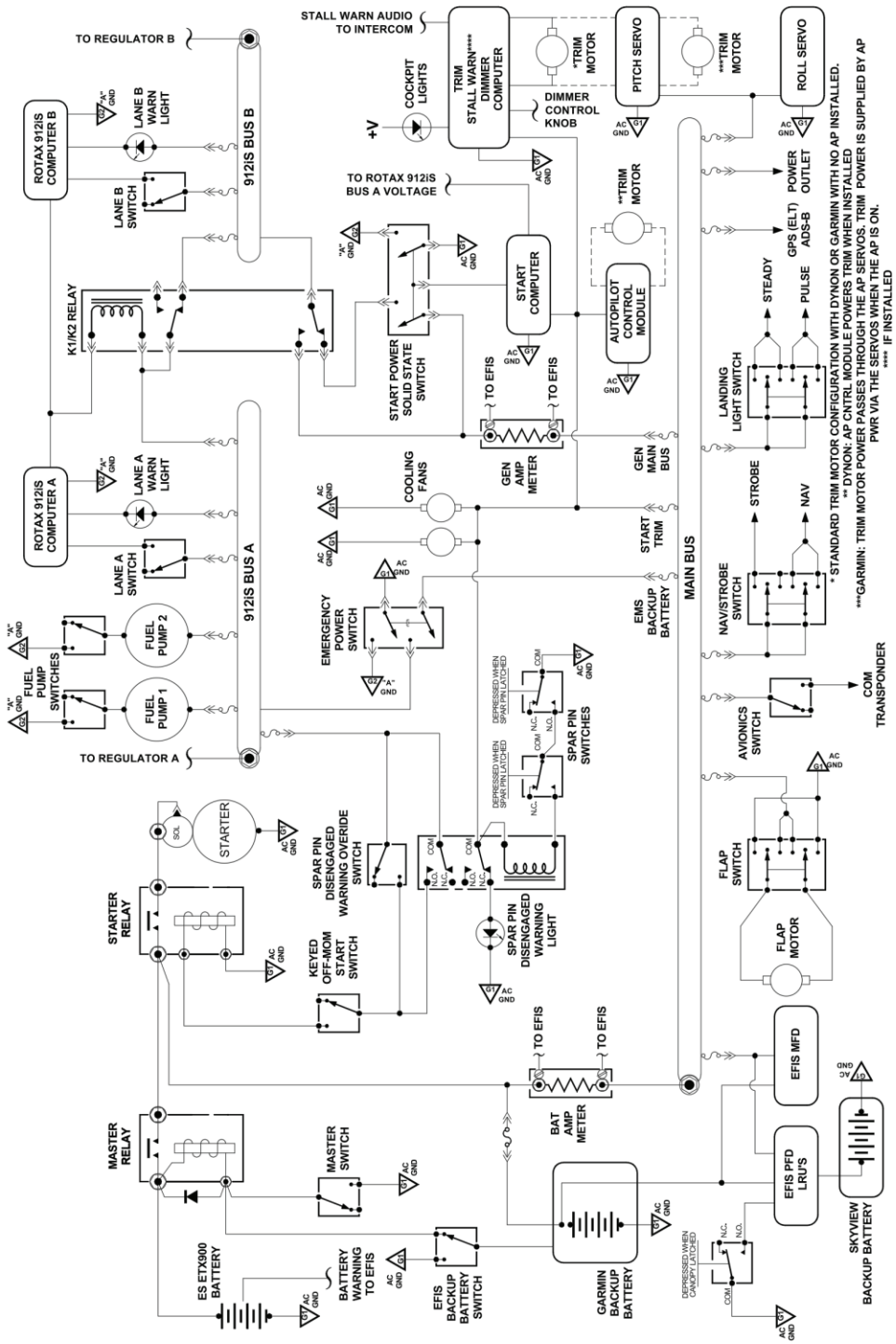
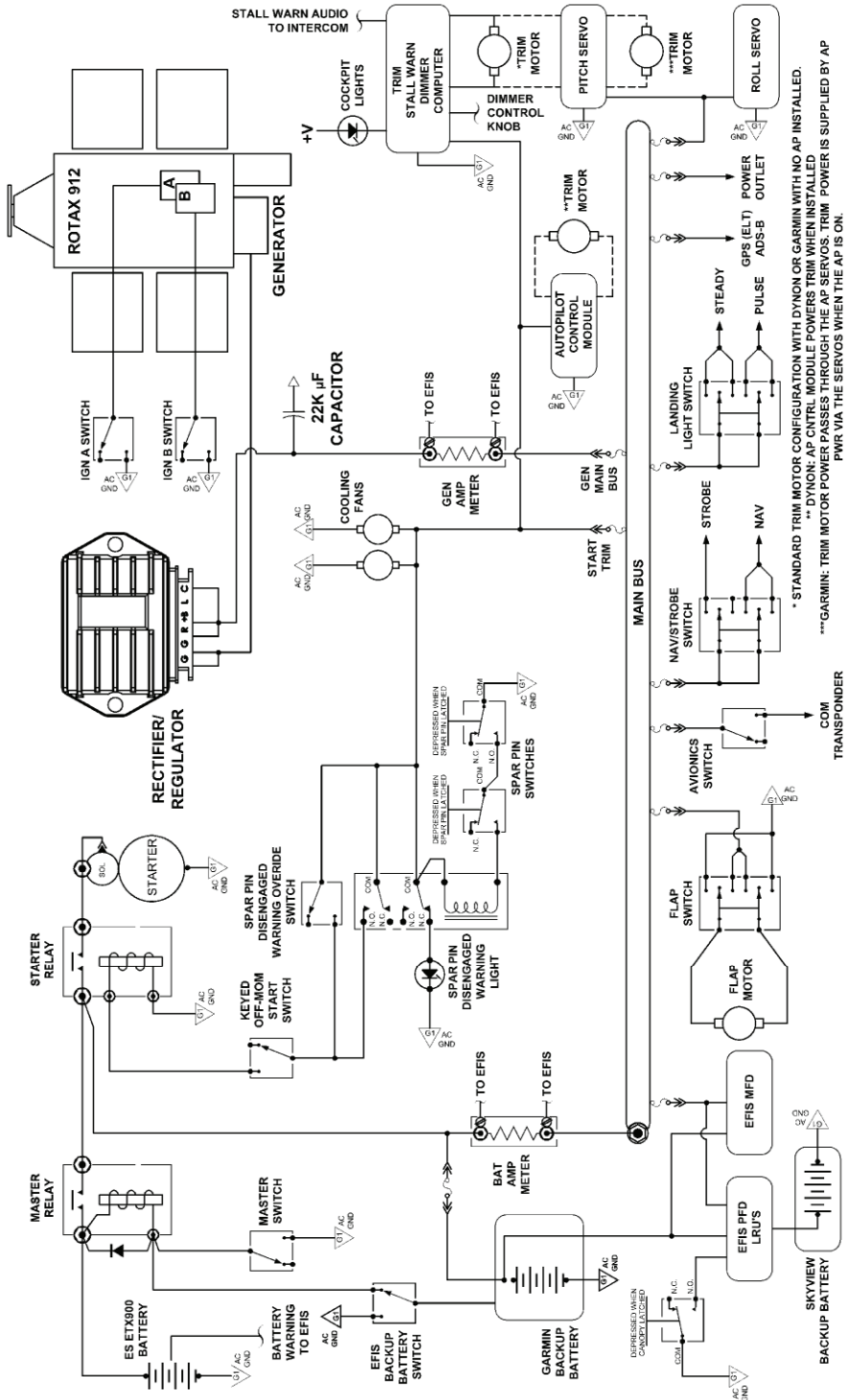

FIGURE 7-7 ROTAX 912 IS ELECTRICAL SYSTEM



* STANDARD TRIM MOTOR CONFIGURATION WITH DYNON OR GARMIN WITH NO AP INSTALLED.
 ** DYNON: AP CNTRL MIDDLE POWERS TRIM WHEN INSTALLED
 *** GARMIN: TRIM MOTOR POWER PASSES THROUGH THE AP SERVOS: TRIM POWER IS SUPPLIED BY AP PWK VIA THE SERVOS WHEN THE AP IS ON.

FIGURE 7-8 912 ULS ELECTRICAL SYSTEM

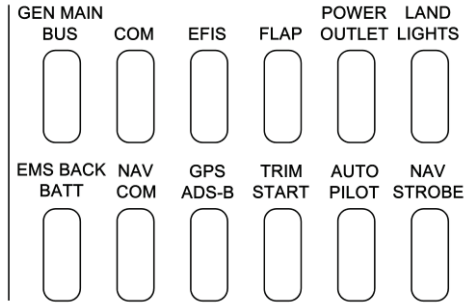

FIGURE 7-9 FUSE PANEL DIAGRAM - iS

CAUTION

Place Master Switch in the OFF position before replacing any fuse.

NOTE

Replacement fuses rated 3A or greater must be of the type that illuminate when blown. Spare fuses must be carried; one 2A, one 3A, two 5A, three 7.5A, one 10A and two 30A.

<u>Circuit</u>	<u>Fuse Value</u>
GEN MAIN BUS	30A
COM (GTR 205x)	7.5A
COM (GTN 650Xi)	10A
EFIS (Single or Dual Screen)	7.5A
FLAP	5A
POWER OUTLET	5A
LAND LIGHT (Single)	5A
LAND LIGHT (Dual)	7.5A
EMS BACK BATT	30A
NAV COM (GTN 650Xi)	7.5A
GPS ADS-B	2A
TRIM START	5A
AUTO PILOT	3A
NAV STROBE	7.5A

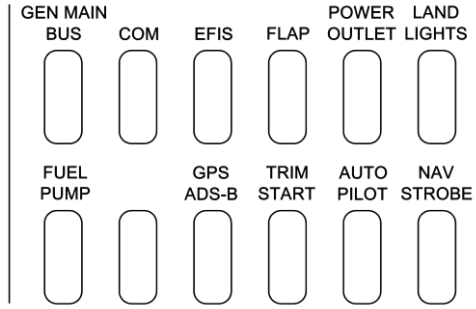

FIGURE 7-10 FUSE PANEL DIAGRAM - ULS

CAUTION

Place Master Switch in the OFF position before replacing any fuse.

NOTE

Replacement fuses rated 3A or greater must be of the type that illuminate when blown. Spare fuses must be carried; one 2A, one 3A, three 5A, two 7.5A, and one 30A.

Circuit

GEN MAIN BUS

COM (GTR 205x)

EFIS (Single or Dual Screen)

FLAP

POWER OUTLET

LAND LIGHT (Single)

LAND LIGHT (Dual)

FUEL PUMP

GPS ADS-B

TRIM START

AUTO PILOT

NAV STROBE

Fuse Value

30A

7.5A

7.5A

5A

5A

5A

7.5A

5A

2A

5A

3A

7.5A

7.8 iS FUEL SYSTEM

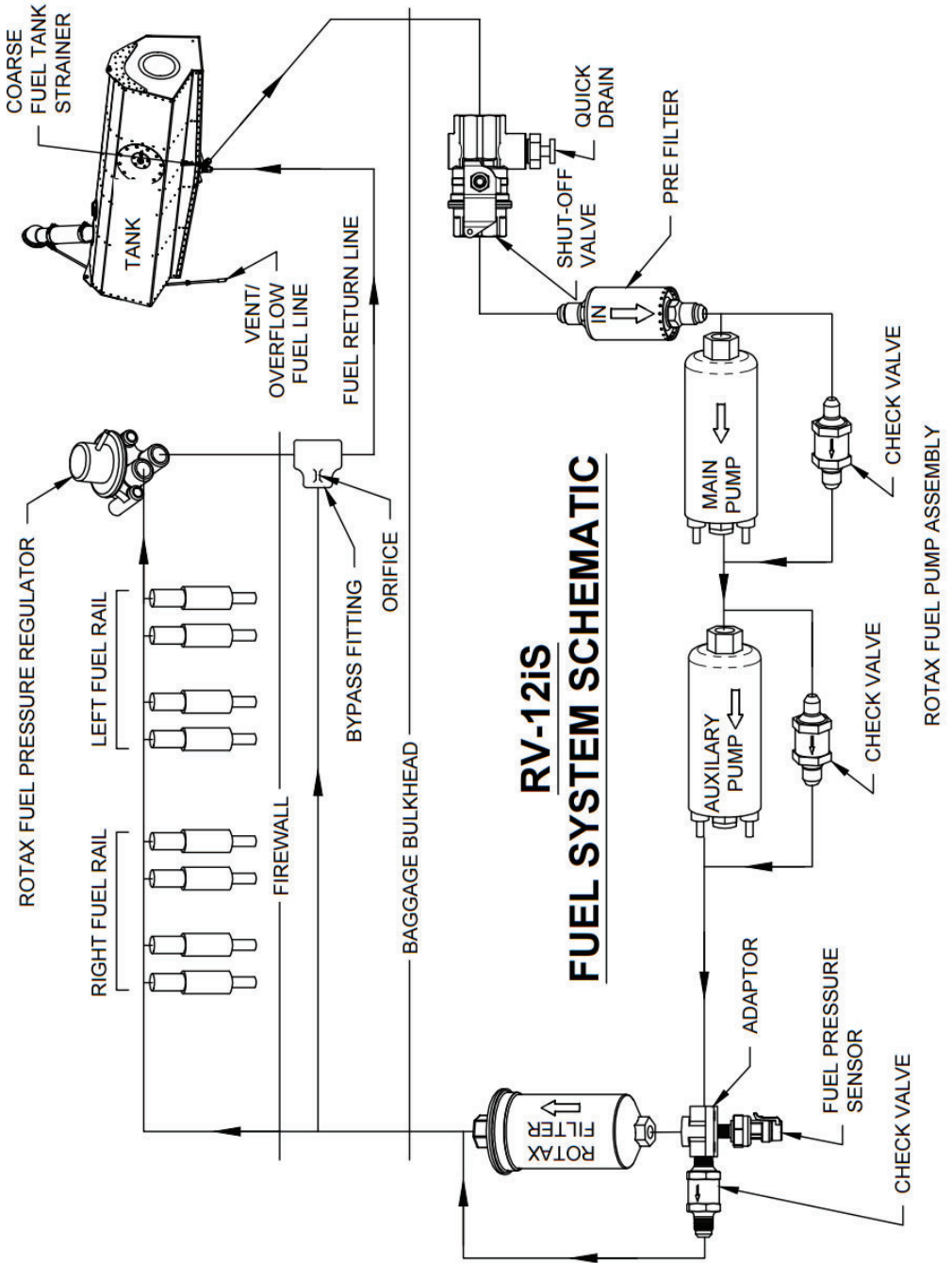

FIGURE 7-11 ROTAX 912iS FUEL SYSTEM

7.9 ULS FUEL SYSTEM

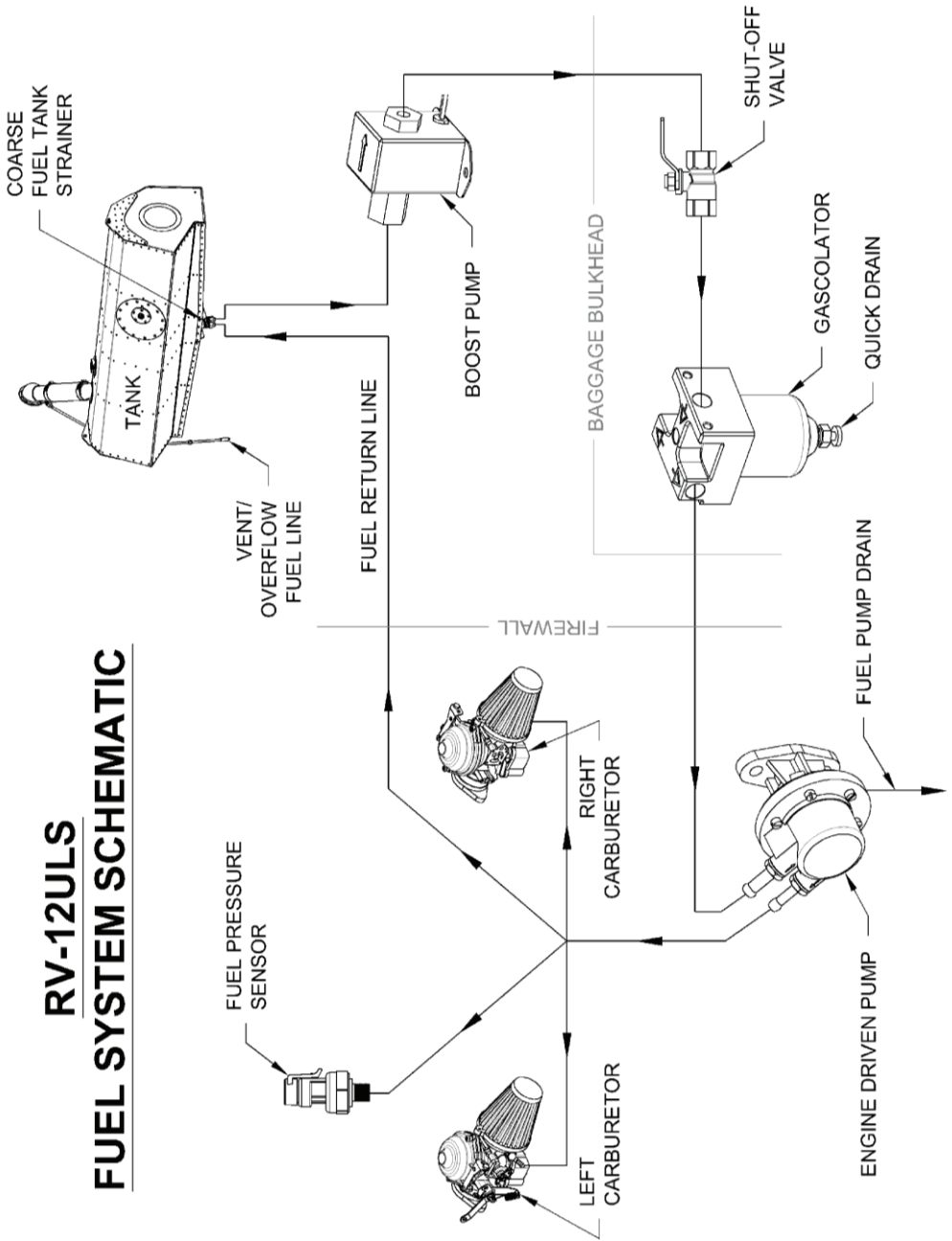

FIGURE 7-12 ROTAX 912 ULS FUEL SYSTEM

7.9 EMERGENCY EQUIPMENT



FIGURE 7-13 EXAMPLE EGRESS HAMMER LOCATION

THIS PAGE INTENTIONALLY LEFT BLANK

SECTION 8

HANDLING & SERVICING

INDEX

8.1	INTRODUCTION	8-1
8.2	TORQUES	8-2
8.3	FUEL	8-3
8.4	OIL	8-4
8.5	COOLANT	8-4
8.6	SPARK PLUGS	8-4
8.7	TIRES & TUBES	8-5
8.8	WING REMOVAL/INSTALLATION	8-5
8.9	TOWING	8-5
8.10	TIE DOWN	8-5
8.11	CLEANING & CARE	8-6

8.1 INTRODUCTION

This section contains factory recommended procedures for proper ground handling and routine service.

In addition, it details some specifications related to the maintenance requirements.

In order to retain the expected performance and dependability, your airplane should be maintained and inspected in accordance with the Engine and Airplane maintenance manuals and issued service bulletins.

8.2 TORQUES

TABLE 8-1 Rotax 912 iS

	ft-lb	in-lb	N-m
Oil Tank Drain Screw	18	221	25
Oil Filter	Hand Tighten		
Magnetic Plug	18	221	25
Water Pump Drain Screw	7	89	10
Spark Plugs 12 mm Thread / 16 mm Hex	15	177	20

TABLE 8-2 Rotax 912 ULS

	ft-lb	in-lb	N-m
Oil Tank Drain Screw	18	221	25
Oil Filter	Hand Tighten		
Magnetic Plug	18	221	25
Water Pump Drain Screw	7	89	10
Carburetor Socket Screws	11	133	15
Spark Plugs 12 mm Thread / 16 mm Hex	15	177	20

NOTE

Check that all values are current and in agreement with the Rotax Service Manual before using these tables as a reference.

8.3 FUEL

Octane Rating

NOTE

See 2.8 “Fuel Limitations”.

CAUTION

Too low an octane rating will cause pre-ignition and detonation, which can damage the piston ring grooves, skirt and crown. Fuel evaporates and quickly loses its octane rating by osmosis when it lies in a fuel tank or plastic jug. A premium fuel could see its octane rating drop to unusable levels after as little as three weeks. A lower octane rating would have an even shorter usable life.

WARNING

Use of poor quality fuel or winter blend fuels in hot conditions may result in vapor lock.

Aviation Fuels

Only use 100LL AVGAS in combination with proper engine oil. The oil will need to be changed more frequently, see the Rotax service manual.

NOTE

See 2.8 “Fuel Limitations”.

Fueling Procedure

- Plane stopped, engine and master power OFF
- Clamp ground line to exhaust pipe
- Remove filler cap, located right side fuselage aft of rear window
- Protect rear window from fuel spill

NOTE

20.2 US Gallons is a fuel level approximately at the seal between the fuel tank and the filler neck.

- Add fuel. (Max. 20.2 US gallons)
- Replace fuel cap
- Remove ground clamp
- Wipe away spillage, if any
- Fuel Pump (912 ULS Only) – ON 2 minutes
- (912iS Only) – Allow time for water and contaminants to settle out to the bottom of the tank and drain area.
- Fuel Sample – CHECK for water and contaminants.

8.4 OIL

Specifications

High quality 4-stroke motorcycle oil with gear additives and a “SF” or “SG” API classification.

Type

If running unleaded fuel use full-synthetic or semi-synthetic oils.

If running 100LL AVGAS more than 30% of the time, use mineral or semi-synthetic oils.

Viscosity

Use Chart to determine the viscosity.

Oil Types to Avoid

- Oils with friction modifier additives “anti-friction”, will cause the slipper clutch to slip
- Oils for “conventional” aircraft engines
- Oils designed for diesel engines with insufficient high temp properties and additives

Oil Filter

Tempest part number 825706 (iS/ULS)

Rotax part number 825016 (iS/ULS)

Oil Quantity

Oil Change – 3 Liters

8.5 COOLANT

Type

50% long life antifreeze concentrate without sulfates and phosphates, with anticorrosion additives designed for aluminum mixed with 50% distilled or demineralized water.

8.6 SPARK PLUGS

912ULS

<u>Type</u>	<u>Socket</u>	<u>Electrode Gap</u>
NGK DCPR8E	16mm	.6-.7 mm/.023-.027 in

912iS

<u>Type</u>	<u>Socket</u>	<u>Electrode Gap</u>
NGK DCPR8E	16 mm	.8-.9 mm/.031-.035 in

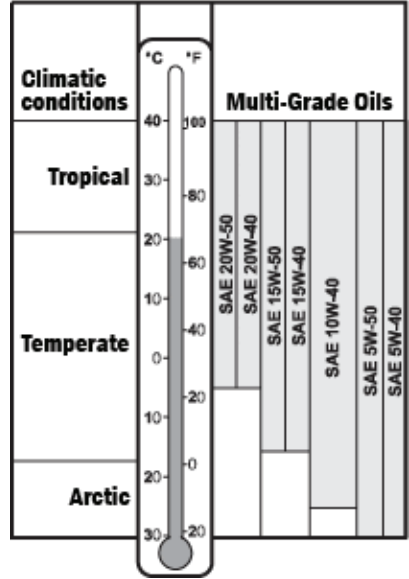

FIGURE 8-1
VISCOSITY

8.7 TIRES & TUBES

All three tires are 5.00 x 5 size and either 4 ply load rating or 6 ply load rating tires are acceptable.

Inflation Pressure:

Nose Tire: 22 psi (optimum)/23 psi (maximum)

Main Tires: 25 psi (optimum)/28 psi (maximum)

8.8 WING REMOVAL/INSTALLATION

Removal and installation of the wings requires two people, one to hold the wing at the tip end and the second person to hold the stub end of the wing. The person handling the tip end of the wing must hold the flaperon approximately in trail as it will tend to flip around and possibly become damaged when disengaged from the fuselage.

Removal

1. Withdraw each of the fuselage pins only enough to release the right wing spar.
2. Remove the right wing assembly and set aside.
3. Remove both of the fuselage pins.
4. Remove the left wing and set aside.

Installation

Installation procedure is reverse of the removal procedure

8.9 TOWING

Towing is done with the collapsible rudder lock/tow bar connected to the nose wheel.

8.10 TIE DOWN

If possible orient the aircraft such that the nose is facing into the wind. With the flaps retracted, tie down the wings first with ropes/chains pulling outward and slightly forward from the wing tie-down points. With the wings secured, pull the aircraft backward to remove slack from the ropes/chains on the wings then attach the tie-down rope/chain to the tail tie-down point. If installed, apply brake and engage the parking brake.

The RV-12iS has 4 tie down points. The tail of the airplane has a Bolt eye TD 3/8-16 which can be used to tie-down the airplane to the ground. Also on each wing, a Bolt eye TD 3/8-16 tie down can be installed using the pre-threaded hard points.

The nose strut can also provide a tie down using the eyelet above the wheel fairing. The flaperons and stabilator controls are secured by fastening the pilot side lap belt around the stick.

The rudder is secured by installing the collapsible tow bar/rudder lock.

8.11 CLEANING & CARE

Clean windshield surfaces only with plastic compatible cleaner designed specifically for airplane windshields.

It is also important to rub the surface gently straight up and down. Using circular wiping motion may create a permanent halo in the windshield. Remove dirt and insects from painted surfaces with water alone and if necessary with a mild detergent or automotive paint cleaner. Remove oil stains, exhaust stains and grime on the lower fuselage skin with a cold detergent.

SECTION 9

SUPPLEMENTS

See the Flight Training Supplement

THIS PAGE INTENTIONALLY LEFT BLANK

THIS PAGE INTENTIONALLY LEFT BLANK

