

SECTION 55:

COMMON FUSELAGE HARNES

The following pages illustrate the routing and installation of the WH-00125 RV-14 Common Fuselage Harness in the aircraft.

The information below is intended to clarify the organization of the WH-00125 drawing package (available on the Van's Aircraft website Downloads page).

The first page in the WH-00125 drawing package is the production drawing for the WH-00125 harness. The production drawing provides the overall wire lengths, gauges, colors, and connections for the common harness. Due to the large amount of information displayed, the production drawing is best viewed on a computer.

The remaining pages in the WH-00125 drawing package are included for reference and depict the various wire harnesses that connect to the WH-00125 harness. Explanatory notes are also provided.

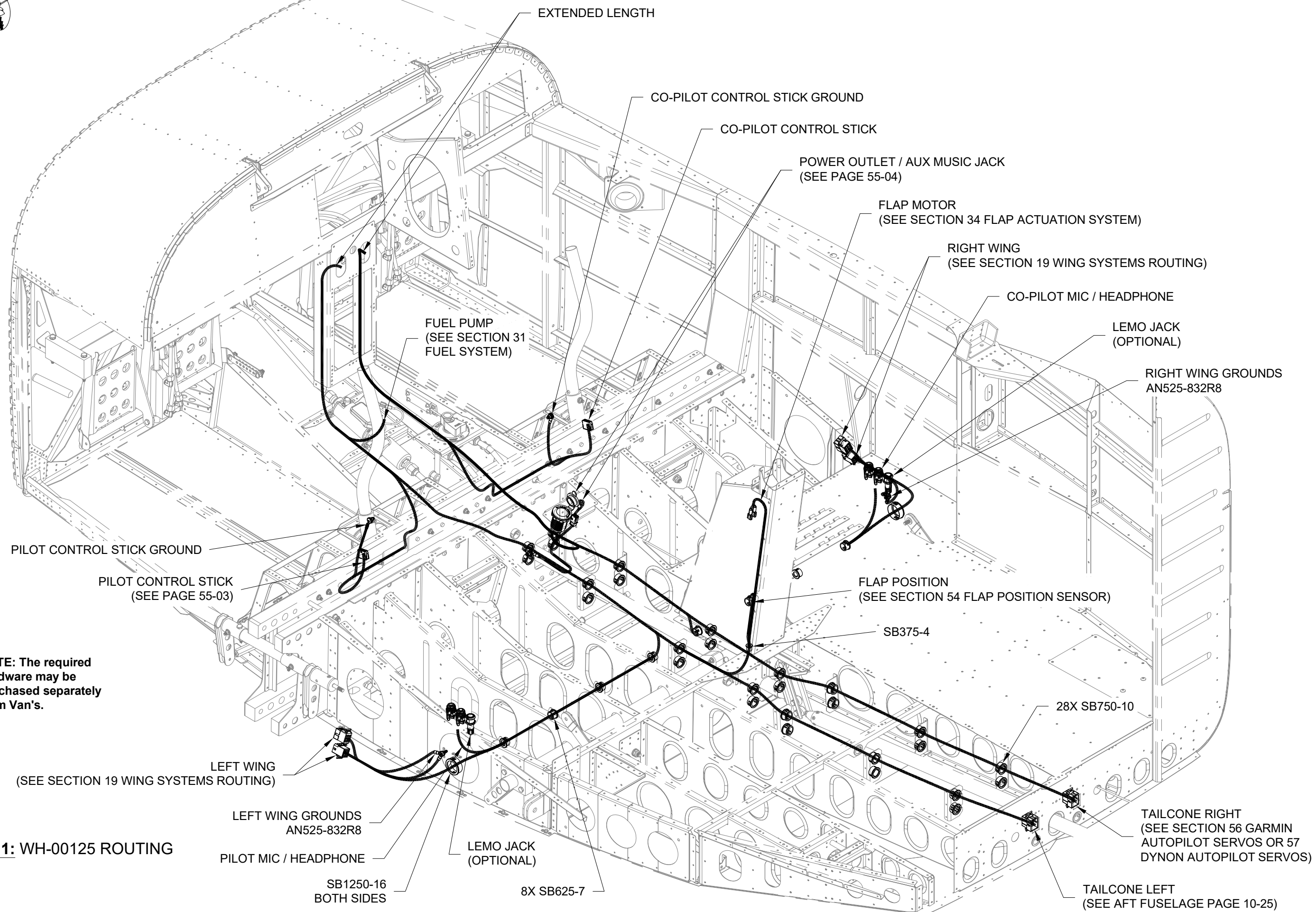

FIGURE 1: WH-00125 ROUTING

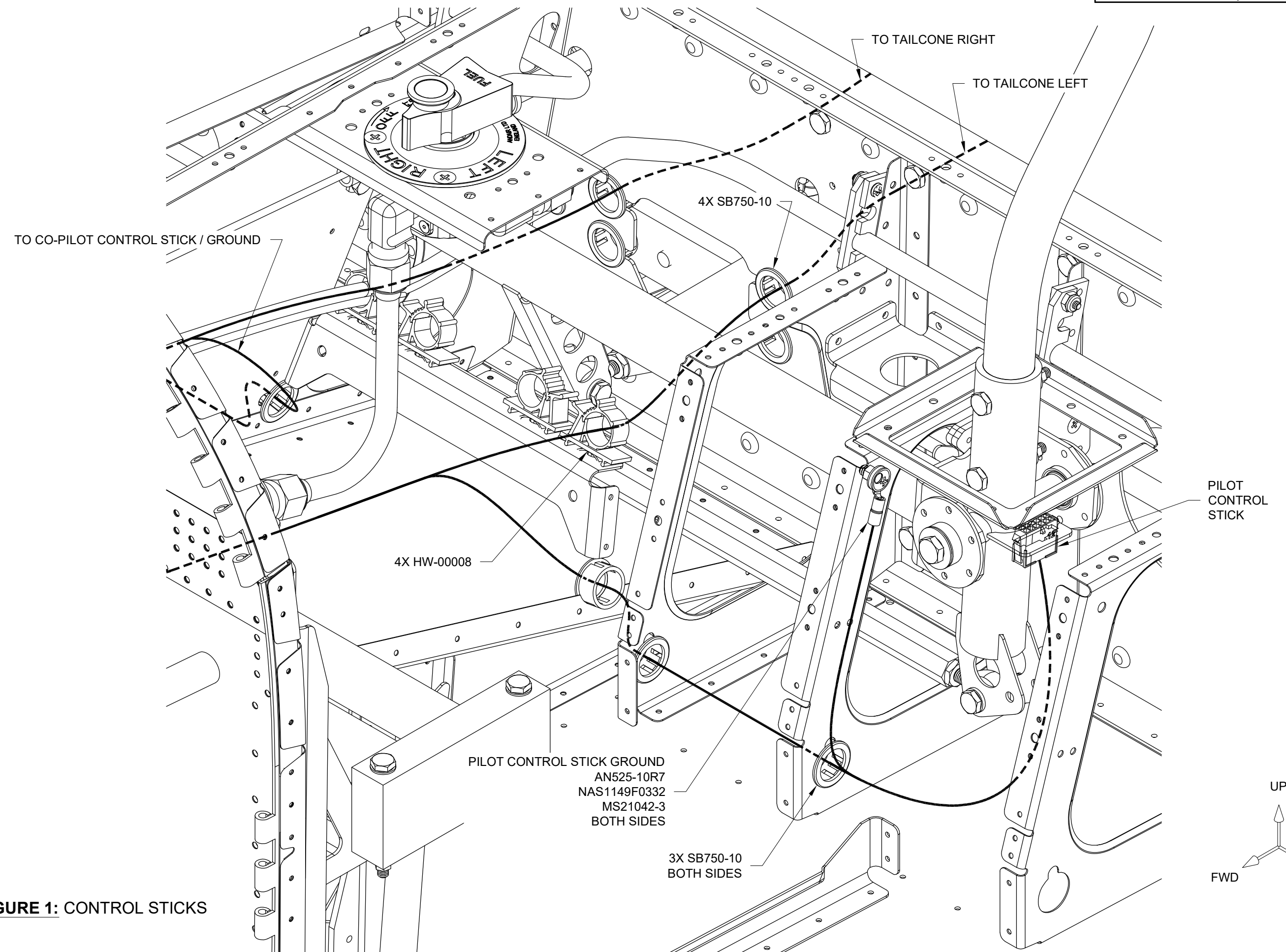
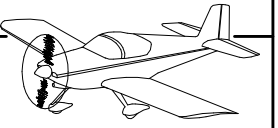

FIGURE 1: CONTROL STICKS

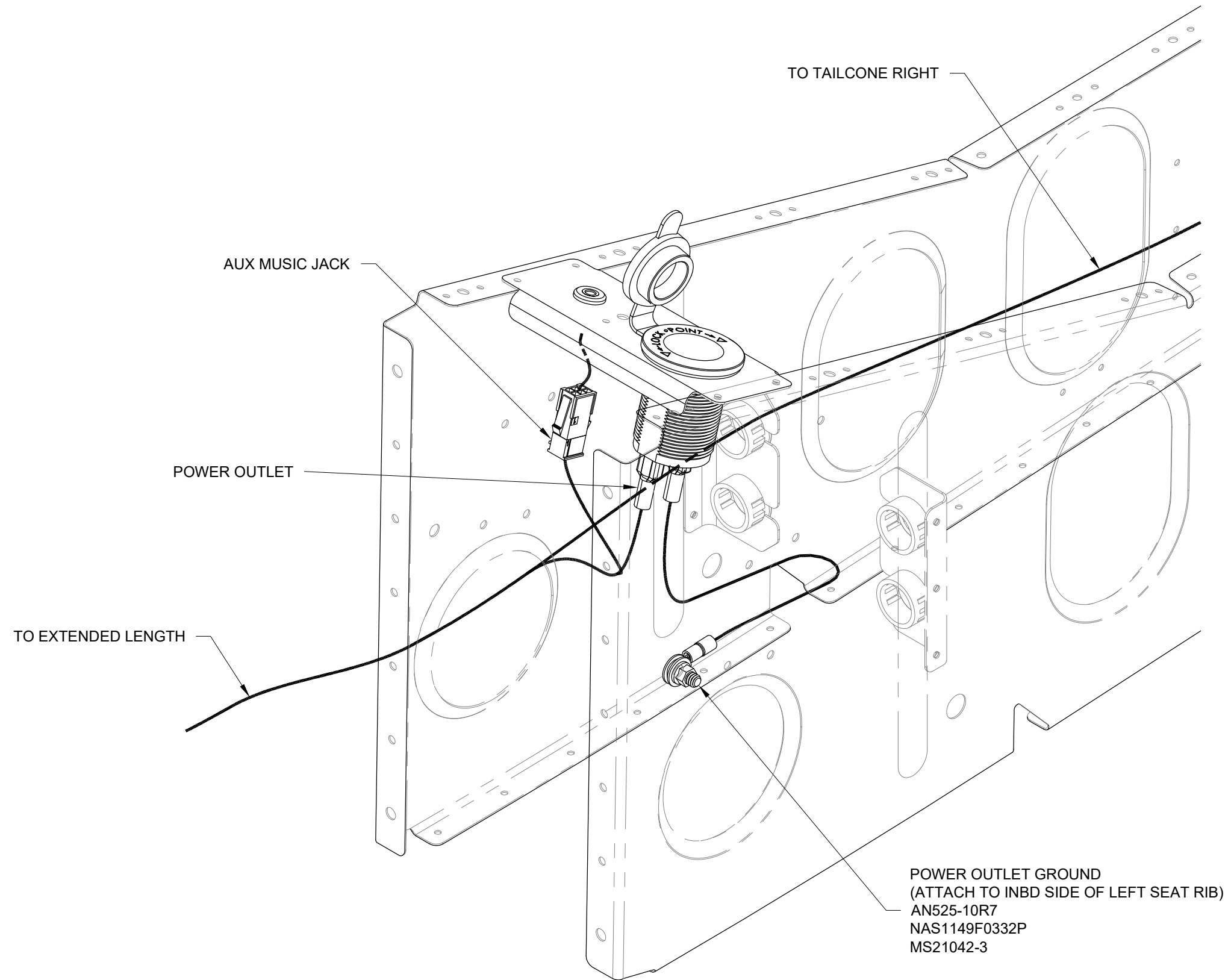
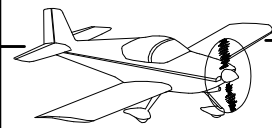
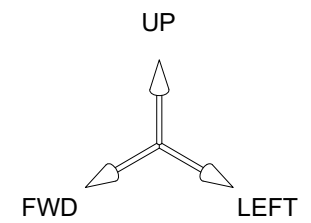

FIGURE 1: POWER OUTLET / AUX MUSIC JACK





Note: This page depicts typical antenna installation locations. Antenna's and antenna cables are not supplied with the common fuselage harness.

The Van's Aircraft factory demonstrators have an archer antenna installed in the right wing tip.

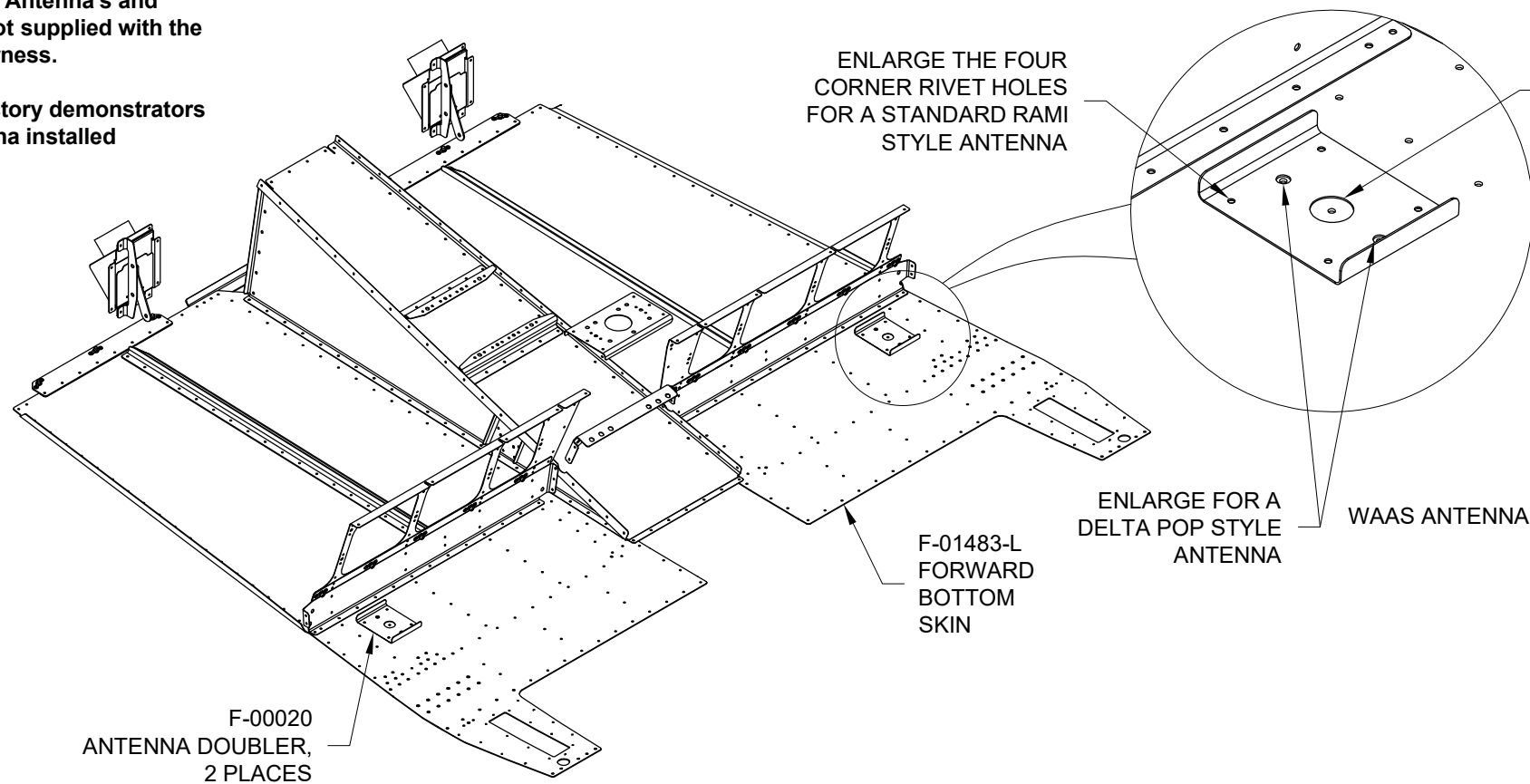

FIGURE 1: COM ANTENNA LOCATIONS

ENLARGE HOLES AS REQUIRED FOR THE TYPE COM ANTENNA IN USE SEE PAGE 28-02

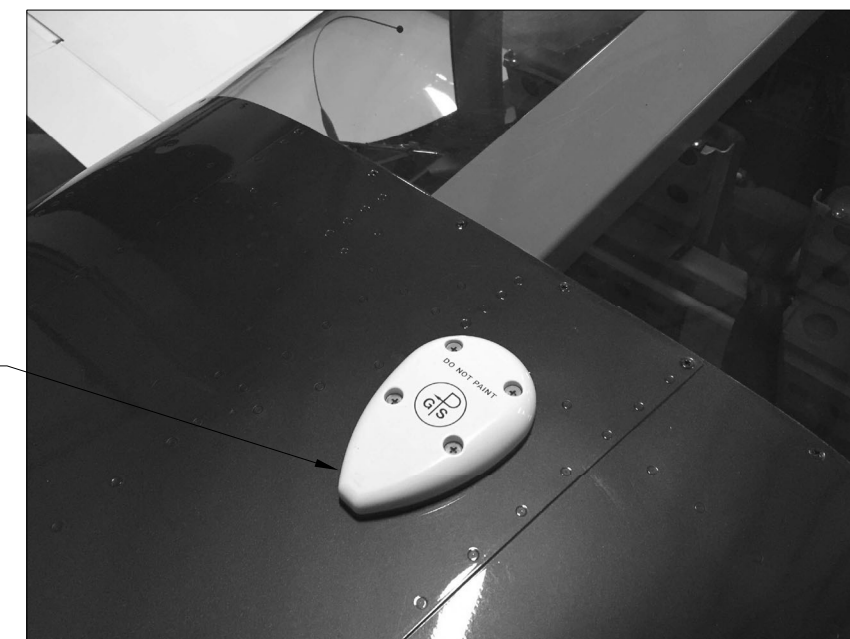

FIGURE 3: WAAS GPS ANTENNA LOCATION

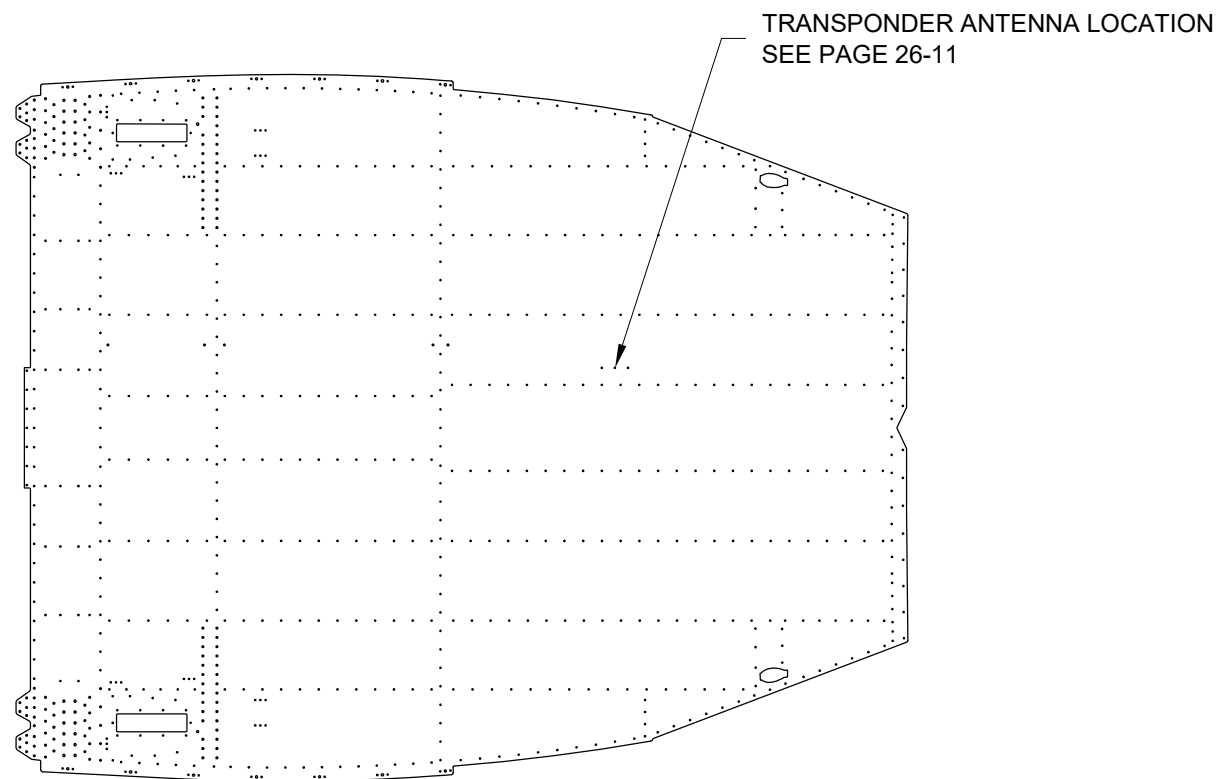

FIGURE 2: TRANSPONDER ANTENNA

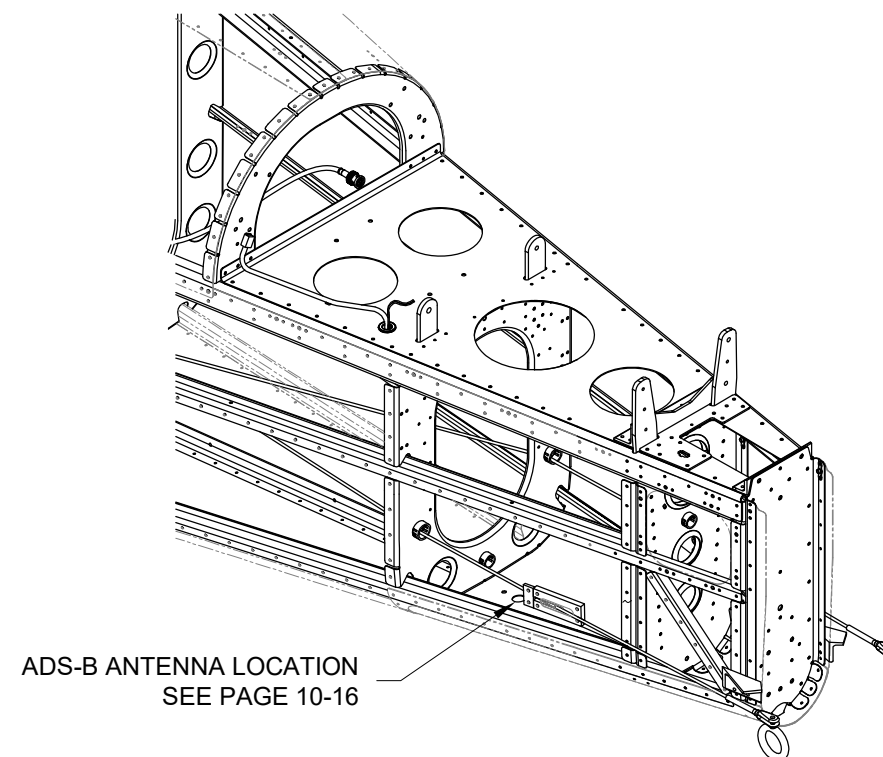

FIGURE 4: ADS-B ANTENNA LOCATION



THIS PAGE INTENTIONALLY LEFT BLANK