

SECTION 29: FWD MID FUSE SIDE

STRUCTURE

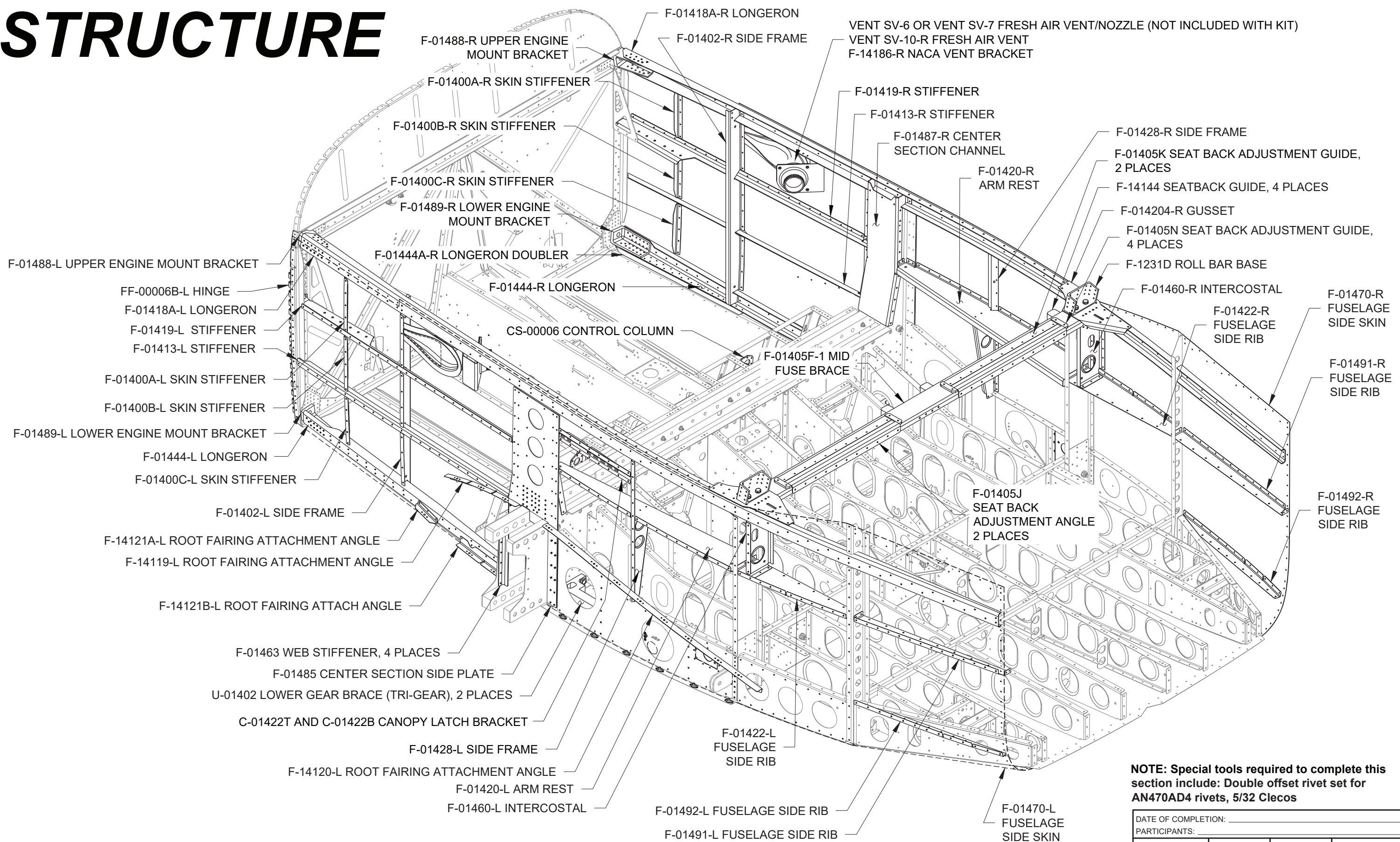

NOTE: Special tools required to complete this section include: Double offset rivet set for AN470AD4 rivets, 5/32 Clecos

| | | | |
|---------------------|-------------|-------|------------|
| DATE OF COMPLETION: | | | |
| PARTICIPANTS: | | | |
| DATE: 03/03/26 | REVISION: 2 | RV-14 | PAGE 29-01 |



NOTE: Except where separate instructions and/or figures exist for both the left and right sides of the aircraft, only the left side parts, assemblies, or installations will be shown.

It is the builder's choice as to whether to complete all steps for the left side before repeating those steps for the right side or to complete each step for both left and right sides before moving to the next step.

Step 1: Prime the F-01483-L & -R Forward Bottom Skins and F-01484 Center Bottom Skin where overlap will occur. See Figure 1.

It is recommended that all overlapping skins in this section be primed along any areas of contact.

Step 2: Join the Forward Fuselage Lower Structure with the Mid Fuselage Lower Structure by sliding the assemblies together on a sturdy, padded, work table.

Overlap and cleco the F-01483-L & -R Forward Bottom Skins, F-01484 Center Bottom Skin and F-01454 Muffler Shroud Ramp as shown in Figure 1.

Step 3: Mark the F-01405B Bulkhead Bar Assemblies for later reinstallation and remove them from the fuselage. See Figure 1.

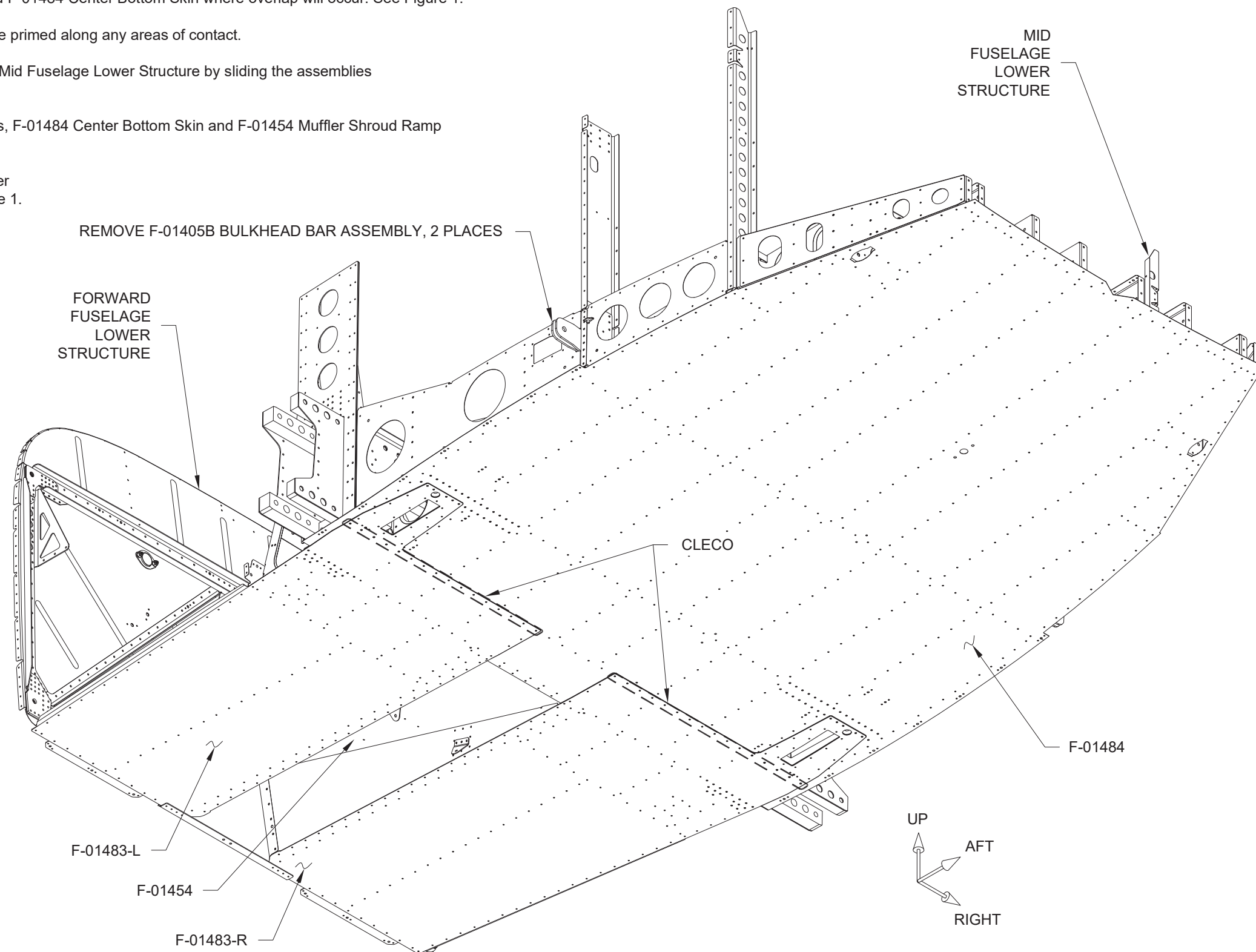

FIGURE 1: FUSELAGE
TRI-GEAR VERSION SHOWN



- Step 1: (Tri-Gear) Mask off the forward and aft mating surfaces of the U-01402 Lower Gear Braces and prime.
- Use Boelube to lubricate the mating surfaces of the lower gear braces for installation.
- Step 2: (Tri-Gear) Apply pipe thread sealant to an F 69-F-04X02 Brass Elbow and install it in the U-01402 Lower Gear Brace. Clock the brass elbows as shown in Figure 2.
- Step 3: (Tri-Gear) Bolt the F-01442 Lower Drag Fitting and U-01402 Lower Gear Brace to the fuselage as shown in Figure 2. Leave the nuts loose for now.
- Step 4: (Tail Dragger) Bolt the F-01442 Lower Drag Fitting to the fuselage as shown in Figure 1. Leave the nuts loose for now.
- Step 5: Bolt the F-01464-L Upper Drag Fitting to the fuselage as shown in Figure 2. Leave the nut loose to allow for rotational positioning.
- Step 6: Cleco the F-01485 Center Section Side Plate to the fuselage. Install as many clecos as is practical.
- Firmly clamp the F-01464-L Upper Drag Fitting to the center section side plate.
- Step 7: Firmly tighten the bolts in the upper drag fitting and lower drag fitting.
- Step 8: Match-Drill #40 the .098 holes in the F-01485 Center Section Side Plate into the F-01464-L Upper Drag Fitting.
- Once drilled, the F-01485 becomes the F-01485-L Center Section Side Plate.
- Step 9: Remove the center section side plate from the fuselage and deburr.
- Step 10: Cleco the center section side plate to the fuselage, installing the clecos from the inside of the fuselage.

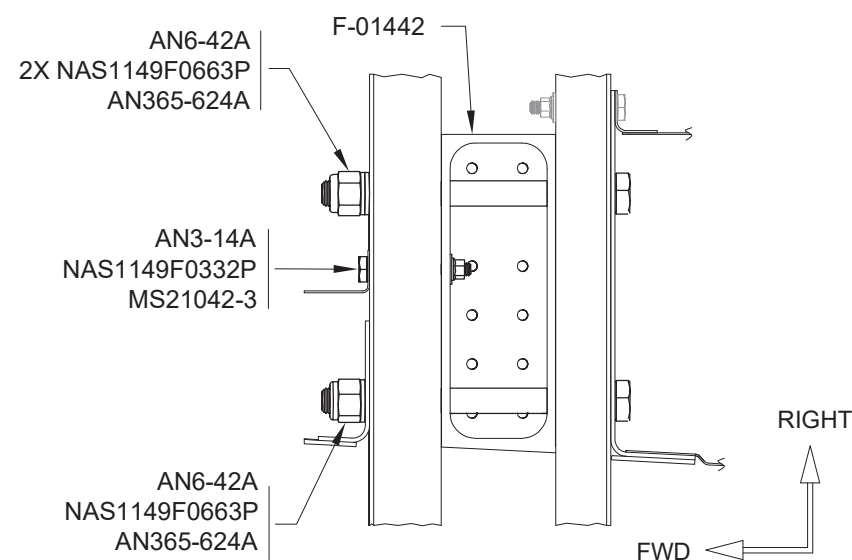

FIGURE 1: LOWER DRAG FITTING INSTALLATION
TAIL DRAGGER HARDWARE SHOWN

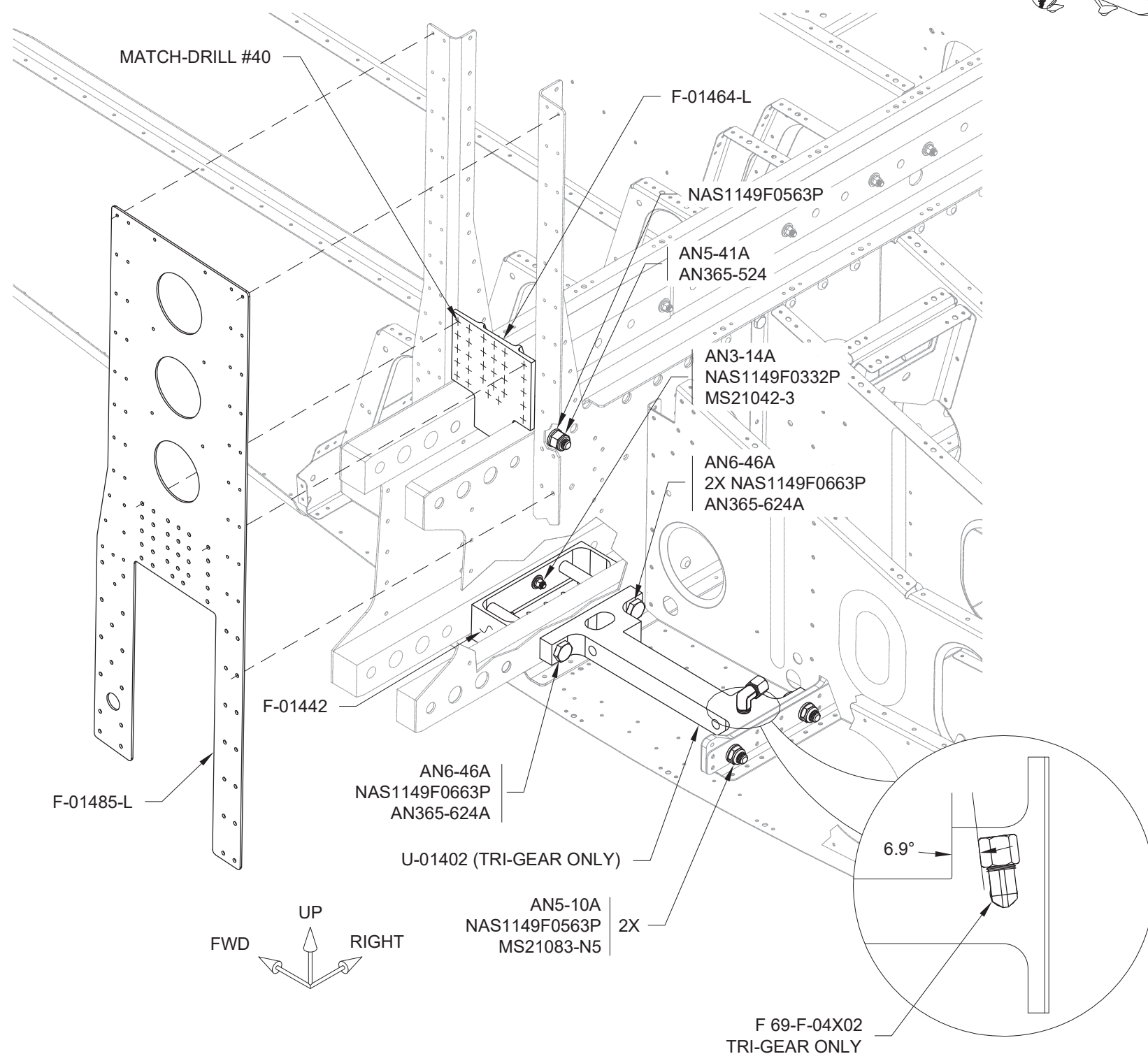
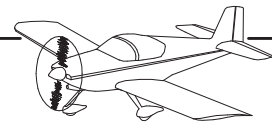

FIGURE 2: DRAG FITTINGS AND SIDE PLATE INSTALLATION
TRI-GEAR LOWER DRAG FITTING AND GEAR BRACE HARDWARE SHOWN



Step 1: (If required) Use a step drill to enlarge the holes in the CS-00006 Control Column as necessary to fit the VA-146 Flange Bearings as shown in Figure 1.

Step 2: Final-Drill #12 the holes in the CS-00006 Control Column as shown in Figure 1.

Step 3: Cleco the VA-146 Flange Bearings to the CS-00006 Control Column as shown in Figure 1.

Step 4: Final-Drill #30 the holes common to the VA-146 Flange Bearings and CS-00006 Control Column called out in Figure 1.

Step 5: Trim the forward left VA-146 Flange Bearing to match the CS-00006 Control Column as shown in Figure 1.

Step 6: Rivet the VA-146 Flange Bearings to the CS-00006 Control Column as shown in Figure 1.

NOTE: The hardware depicted in Figure 4 represents a nominal stack up. Add, remove or substitute shims or washers as necessary to avoid pre-loading the Control Column laterally. A lateral pre-load will produce an undesirable increase in pitch control friction and bearing wear.

Step 6: (If required) Separate and radius the F-14146A and F-14146B Control Column Shims as shown in Figure 2. Completely circular shims are not required.

Step 7: Bolt the Control Column Assembly to the Bearing Bracket Assemblies in the Forward Fuselage Lower Structure as shown in Figure 3 and Figure 4.

Tighten the hardware on one side of the Control Column Assembly first, then add, remove, or substitute shims or washers as necessary on the other side.

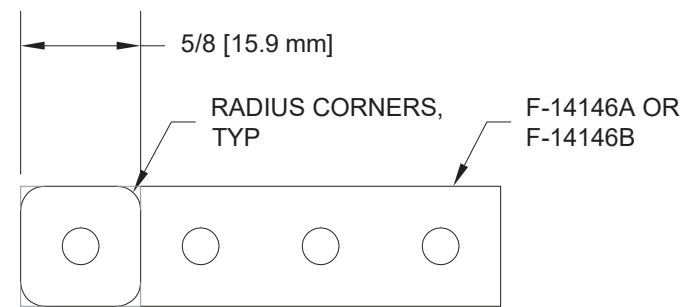

FIGURE 2: CONTROL COLUMN SHIMS

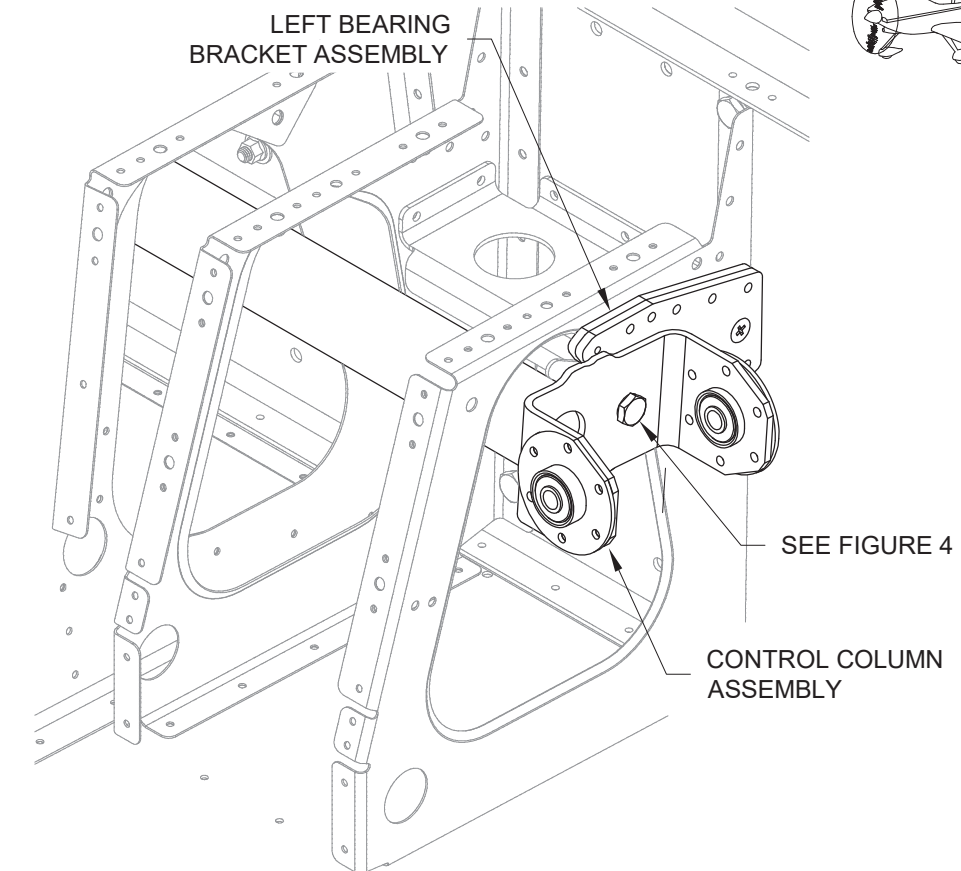

FIGURE 3: CONTROL COLUMN ASSEMBLY INSTALLATION (COVER PLATE NOT SHOWN FOR CLARITY)

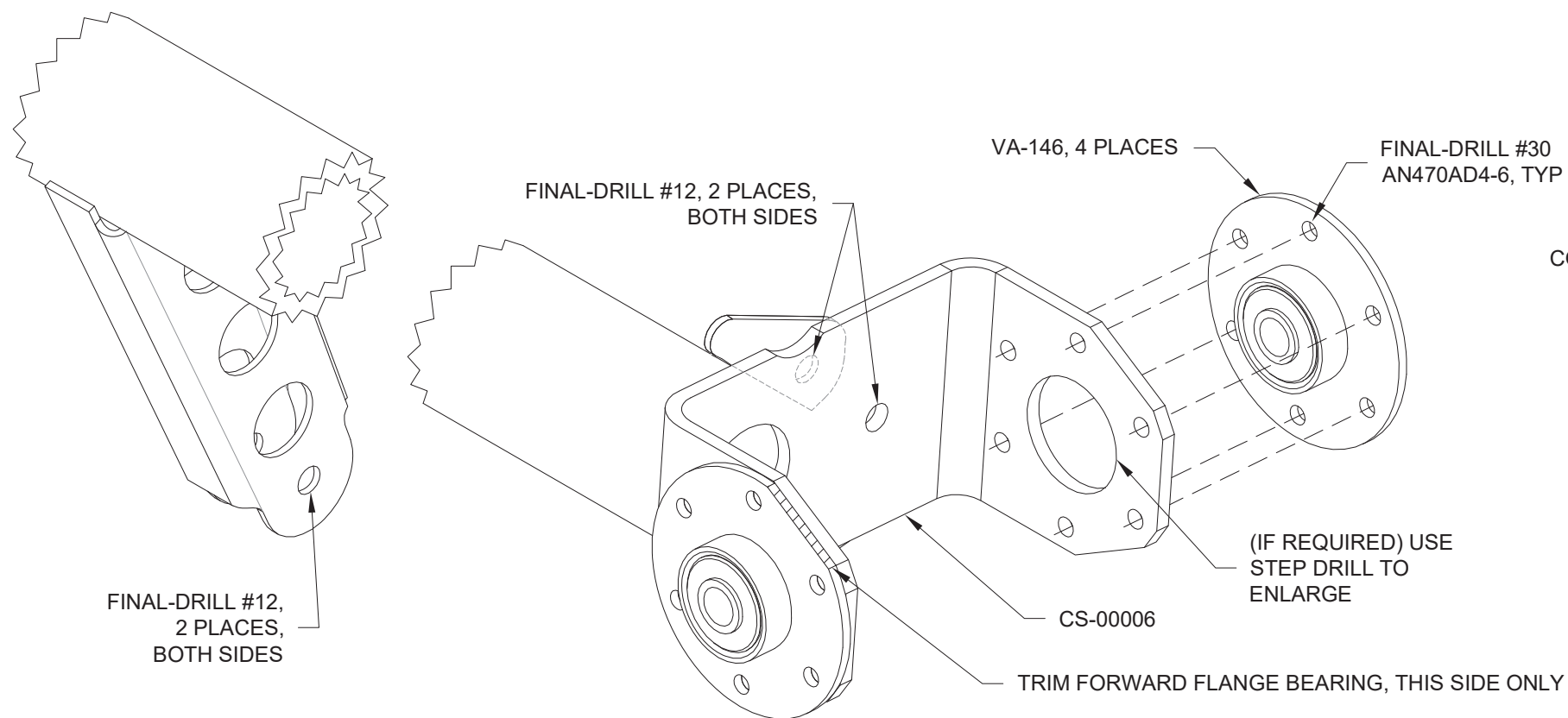

FIGURE 1: CONTROL COLUMN ASSEMBLY

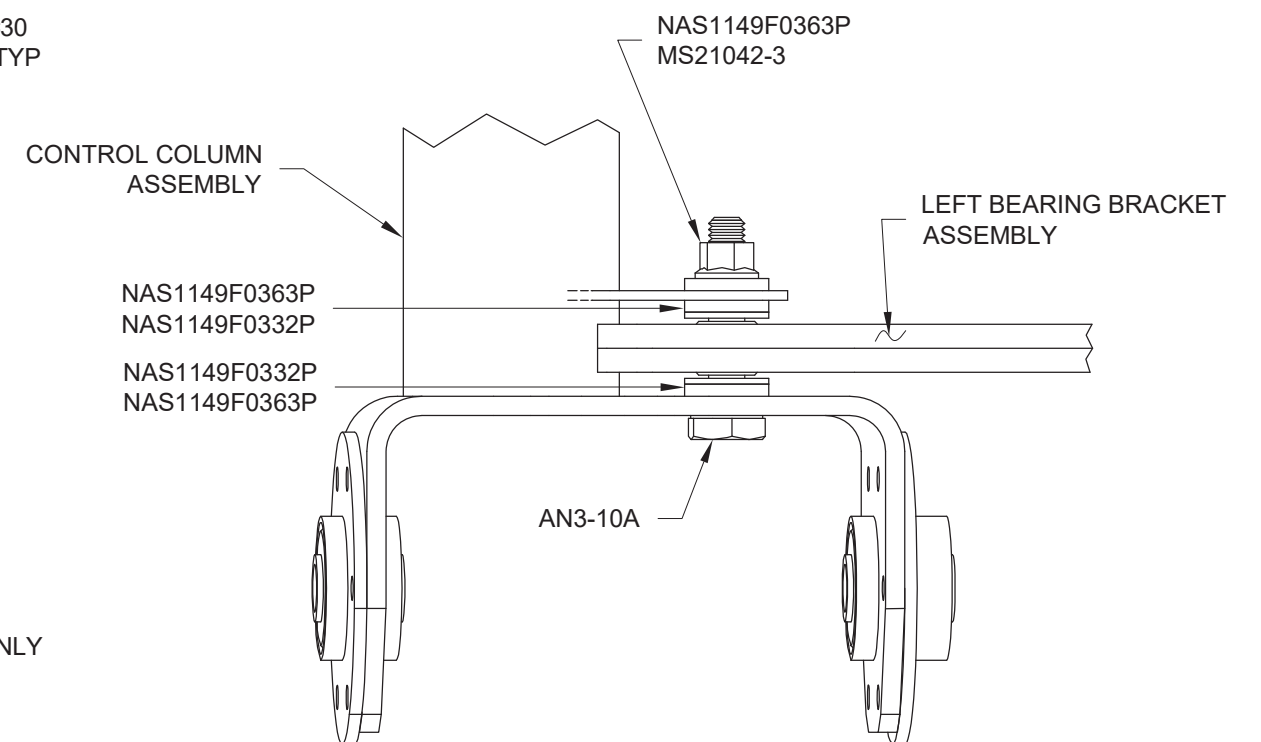

FIGURE 4: CONTROL COLUMN ASSEMBLY HARDWARE



Step 1: Final-Drill #40 all .0625 [1.6 mm] holes in the top flanges of the F-01418A-L longeron.

Step 2: Trim the Longeron as shown in Figure 1.

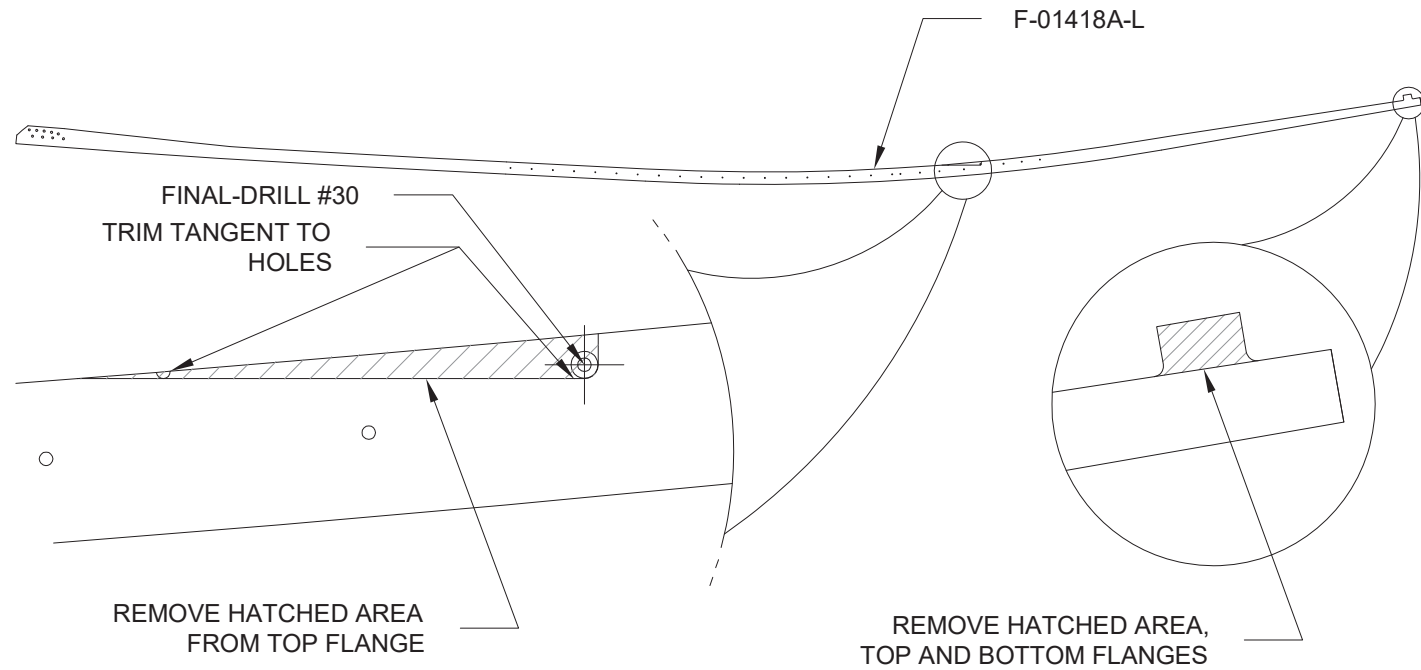

FIGURE 1: TRIM LONGERON

Step 3: Fabricate two Longeron Blocks out of wood. See Figure 2.

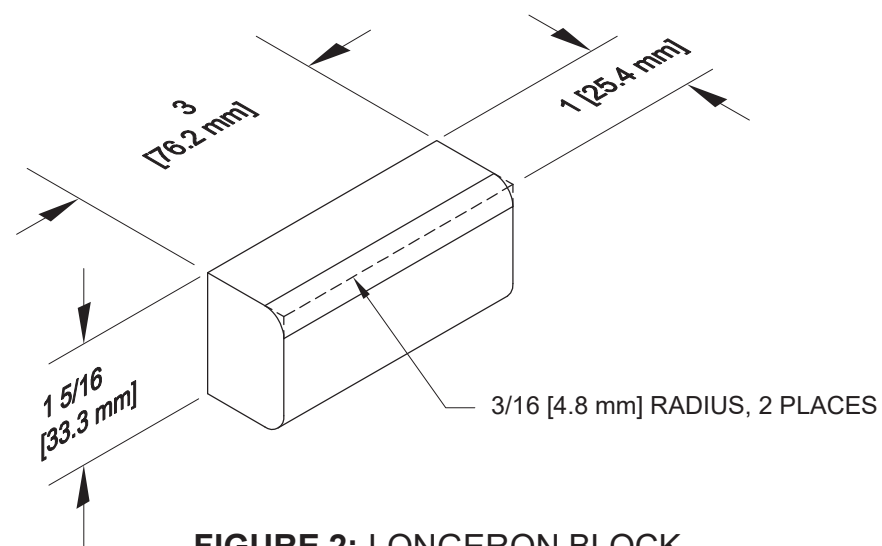

FIGURE 2: LONGERON BLOCK

Step 4: Clamp the Longeron Blocks to the F-01418A-L Longeron as shown in Figure 3. Note the location of the forward edge of the Aft Longeron Block, this is the aft most point where twist in the longeron will occur.

Step 5: Use a digital level to obtain the initial angle for measuring the twist in the F-01418A-L Longeron. Twist the longeron to obtain a 10° degree permanent twist as shown in Figure 3.

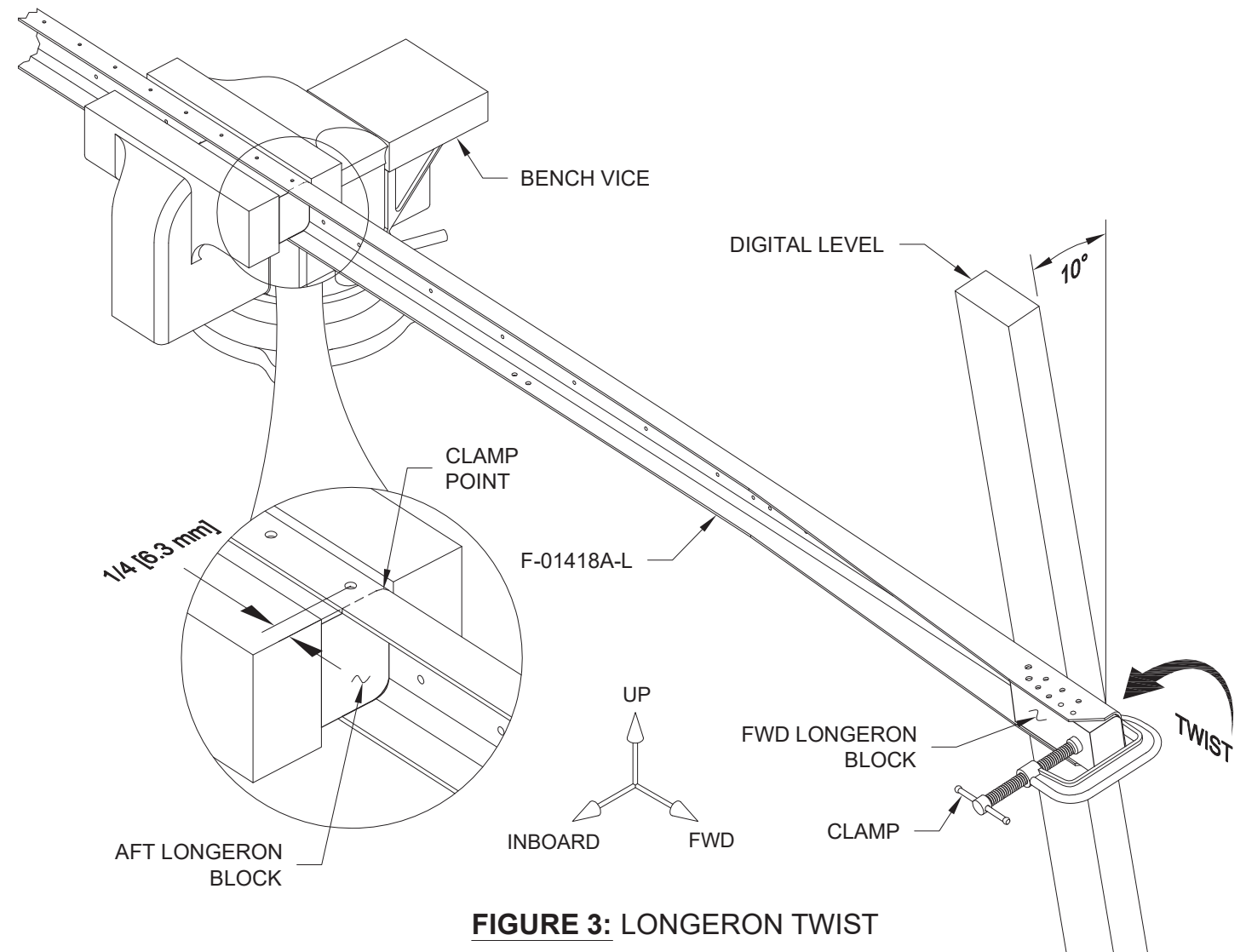

FIGURE 3: LONGERON TWIST

Step 6: Use clecos and clamps to secure the F-01488-L Upper Engine Mount Bracket to the F-01418A-L Longeron as shown in Figure 4.

Step 7: Match-Drill #30 the holes in the upper and lower flanges of the F-01418A-L Longeron into the F-01488-L Upper Engine Mount Bracket. See Figure 4.

Step 8: Final-Drill #20 the four aft most holes in the longeron into the upper engine mount bracket as shown in Figure 4.

Step 9: Uncleco and prime the longeron and upper engine mount bracket.

Step 10: Rivet the upper engine mount bracket to the top and bottom flanges of the longeron as shown in Figure 4.

Hereafter referred to as the Upper Longeron Assembly

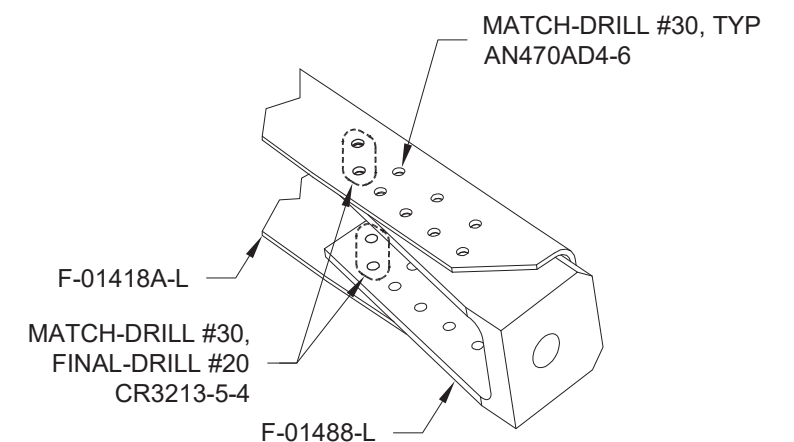
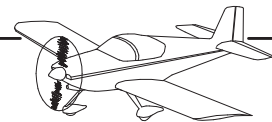

FIGURE 4: UPPER LONGERON ASSEMBLY



Step 1: Final-Drill and trim the F-01444-L Longeron as shown in Figure 1 and Figure 3.

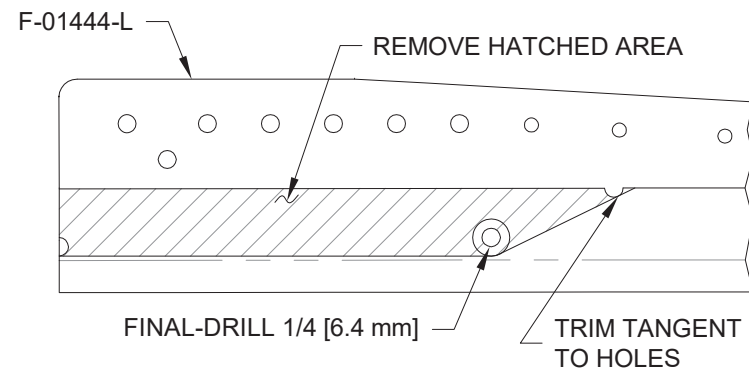

FIGURE 1: TRIM F-01444-L LONGERON (FORWARD END, TOP VIEW)

Step 2: Separate and label the F-01444A-L & -R Longeron Doublers as shown in Figure 2.

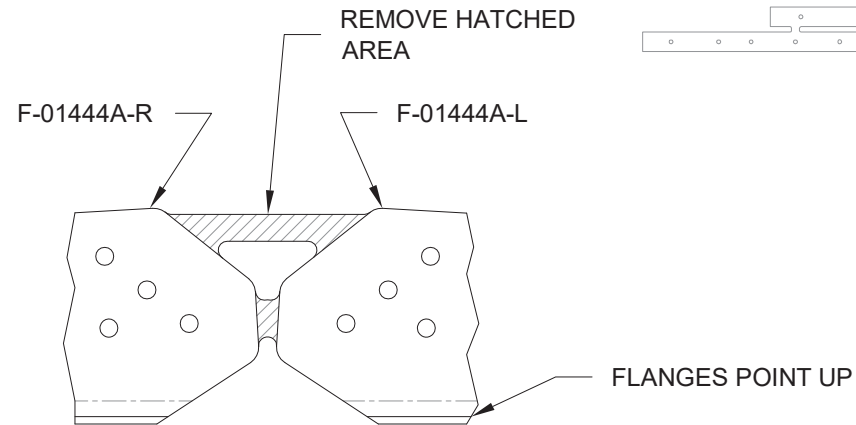

FIGURE 2: SEPARATE LONGERON DOUBLER

Step 3: Use clecos and clamps to secure the F-01489-L Lower Engine Mount Bracket and F-01444A-L Longeron Doubler to the F-01444-L Longeron as shown in Figure 3.

Step 4: Match-Drill 1/8 [3.2 mm] the holes in the side of the F-01444-L Longeron into the F-01489-L Lower Engine Mount Bracket. See Figure 3.

Step 5: Final-Drill #30 the holes in the bottom of the longeron doubler into the F-01444-L Longeron and lower engine mount bracket. See Figure 3.

Step 6: Remove the lower engine mount bracket and longeron doubler from the F-01444-L Longeron.

Step 7: Prime the longerons, longeron doubler and engine mount brackets.

Step 8: Rivet the longeron doubler to the F-01444-L Longeron and lower engine mount bracket using the rivets called out in Figure 3.

Hereafter referred to as the Lower Longeron Assembly.

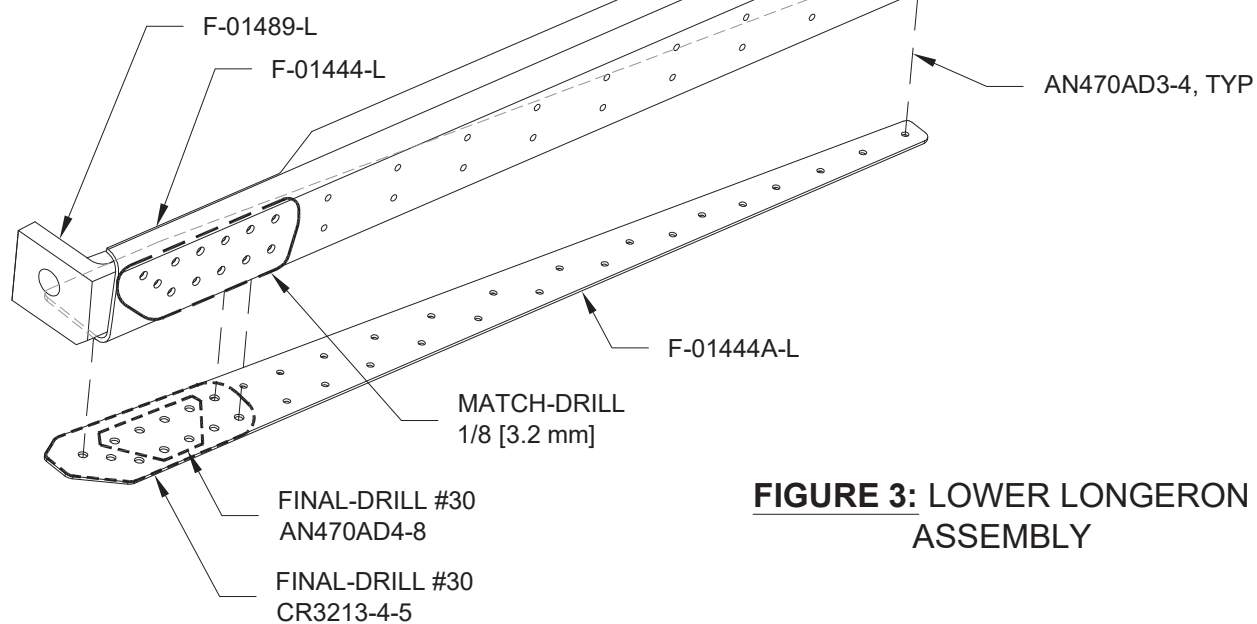

FIGURE 3: LOWER LONGERON ASSEMBLY

Step 9: Separate the F-14134B Cowling Hinge Shims as shown in Figure 4. Retain the remaining shims for use in Section 35.

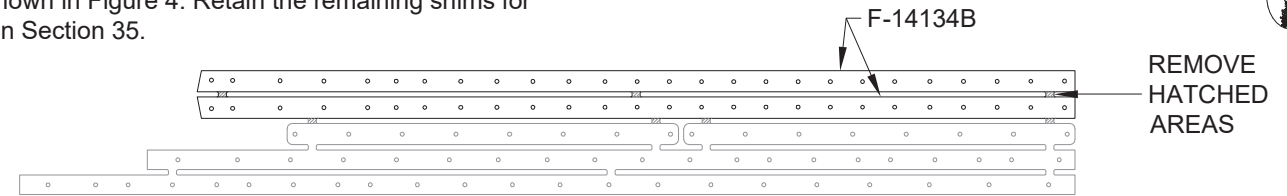

FIGURE 4: SEPARATE F-14134 HINGE SHIMS

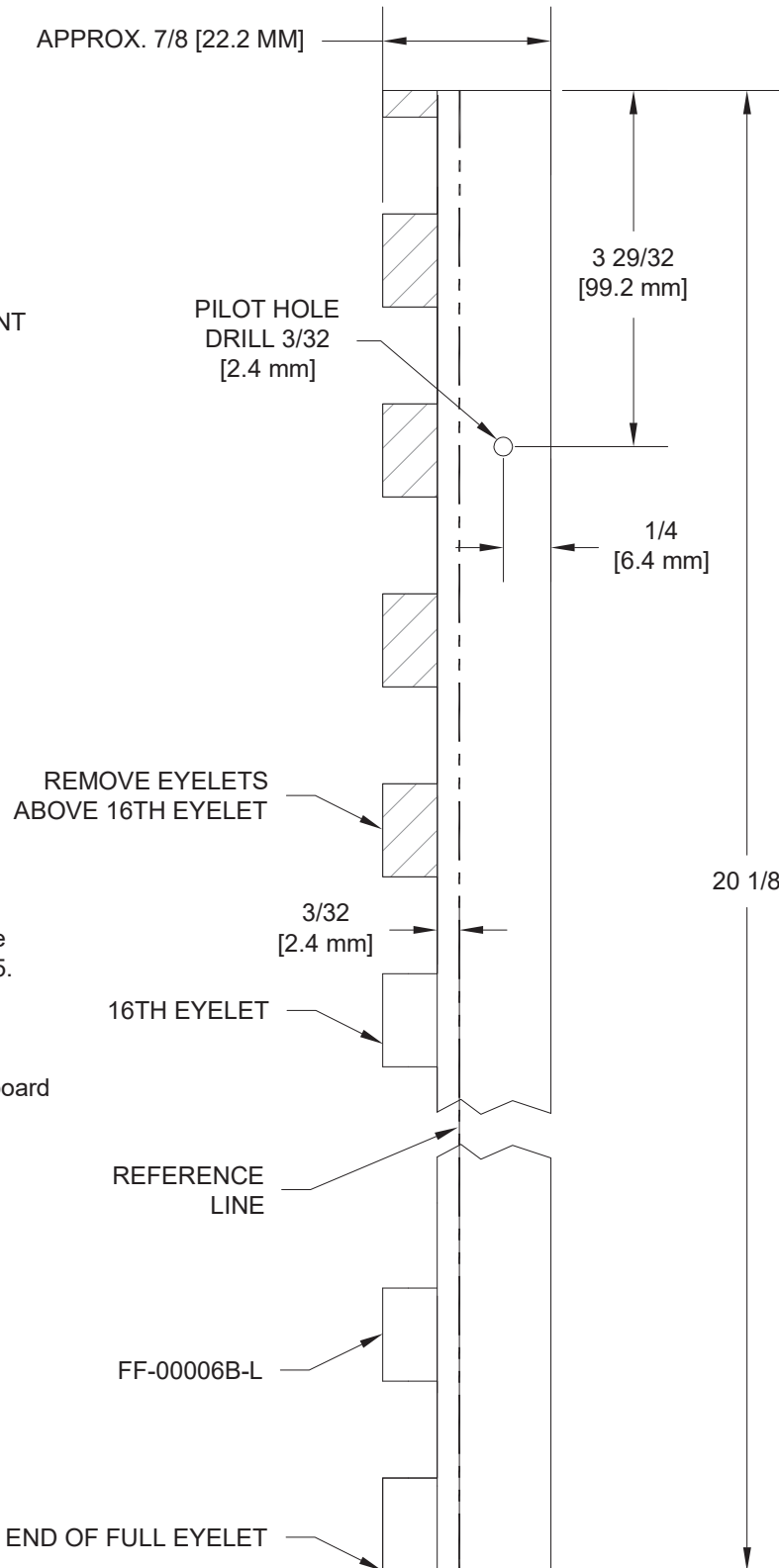

FIGURE 5: HINGE FABRICATION

Step 10: Fabricate the FF-00006B-L Hinge from 1/8 Piano Hinge as shown in Figure 5. See Page 29-08, Figure 1 for orientation and further detail.

Step 11: Mark a reference line on the outboard side of the hinge as shown in Figure 5.



Step 1: Cleco the Upper Longeron Assembly, Lower Longeron Assembly and the F-01402-L Side Frame to the F-01470-L Side Skin as shown in Figure 1 and on Page 29-15, Figure 2.

Step 2: Cleco the forward half of the side skin to the fuselage. Begin clecoing at the F-01485 Center Section Side Plate and move forward.

Step 3: Cleco the side skin to the side flanges and lower flange of the firewall and the F-14134B-L Cowling Hinge Shim. Leave open the holes above the "BEGIN DRILLING HERE" call-out. See Figure 1.

Step 4: Temporarily bolt the Upper and Lower Longeron Assemblies to the firewall as shown in Figure 1.

Step 5: Cleco the FF-00006B-L Hinge to the cowling hinge shim, firewall, and side skin using the pilot hole as shown in Figure 1 and on Page 29-07, Figure 5. Clecos previously installed will prevent the entire hinge from laying flat.

Step 6: With the hinge reference line parallel to the forward edge of the side skin, clamp the hinge and cowling hinge shim securely to the firewall above the pilot hole. Do not remove any clecos at this time.

Step 7: Match-Drill #40 the holes above the pilot hole, progressing upward. Cleco each hole as it is drilled and verify that the hinge reference line remains parallel to the forward edge of the side skin.

Remove the cleco from the pilot hole and match-drill #40. Continue match-drilling #40 the holes below the pilot hole, progressing downward. Remove clecos as necessary to ensure the hinge remains flat against the shim and firewall while drilling. Cleco each hole as it is drilled and verify that the hinge reference line remains parallel to the forward edge of the side skin.

Step 8: Final-Drill #30 the holes common to the side skin and the Upper and Lower Longeron Assemblies as shown in Figure 1.

Step 9: Label and remove the F-00006B-L Hinge and F-14134B-L Cowling Hinge Shim.

Step 10: Dimple the holes in the cowling hinge shim flush on the outboard side.

Step 11: Machine Countersink the holes on the outboard side of the hinge to accept the dimpled cowling hinge shim.

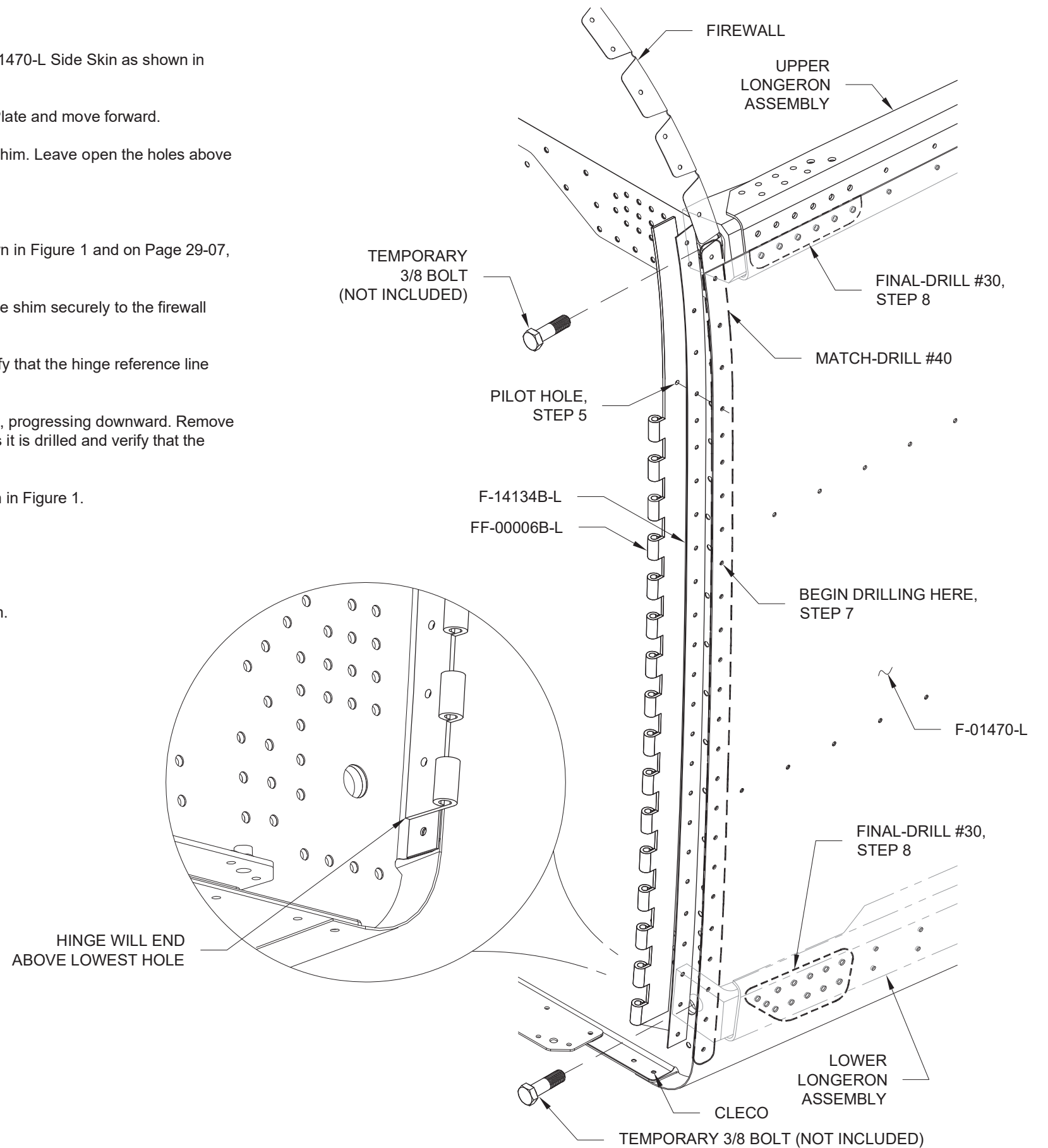
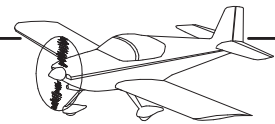

FIGURE 1: FORWARD FUSELAGE DRILLING



Step 1: Final-Drill #30 the holes common to the F-01470-L Side Skin, F-01485-L Center Section Side Plate and F-01464-L Upper Drag Fitting as indicated in Figure 1. Cleco each hole as it is drilled.

Step 2: Remove the center section side plate, side skin, and the Upper and Lower Longeron Assemblies from the fuselage.

Step 3: Machine countersink the holes in the center section side plate to fit a dimpled .032 skin. See Figure 1 for exceptions.

Step 4: Break the indicated edges of the side skin inboard slightly. See Figure 2.

Step 5: Use a file and sanding blocks to radius the top outboard edge of the side skin. See Figure 2 and Figure 3.

Step 6: Dimple all #30 and #40 holes in the side skin except as noted in Figure 1.

Step 7: Use a file and sanding blocks to radius and feather the outboard side of the upper aft corner of the side skin down to a narrow edge as shown in Figure 2.

Step 8: Machine Countersink the outboard holes in the Upper and Lower Longeron Assemblies to accept the dimpled holes in the side skins. See Figure 4 for exceptions.

Step 9: Deburr the edges of the vent cutout in the F-01470-L & -R Side Skins, keeping the outboard edge of the cutout as sharp as practical for best performance. A rounded cutout edge will inhibit airflow separation and reduce airflow through the vent.

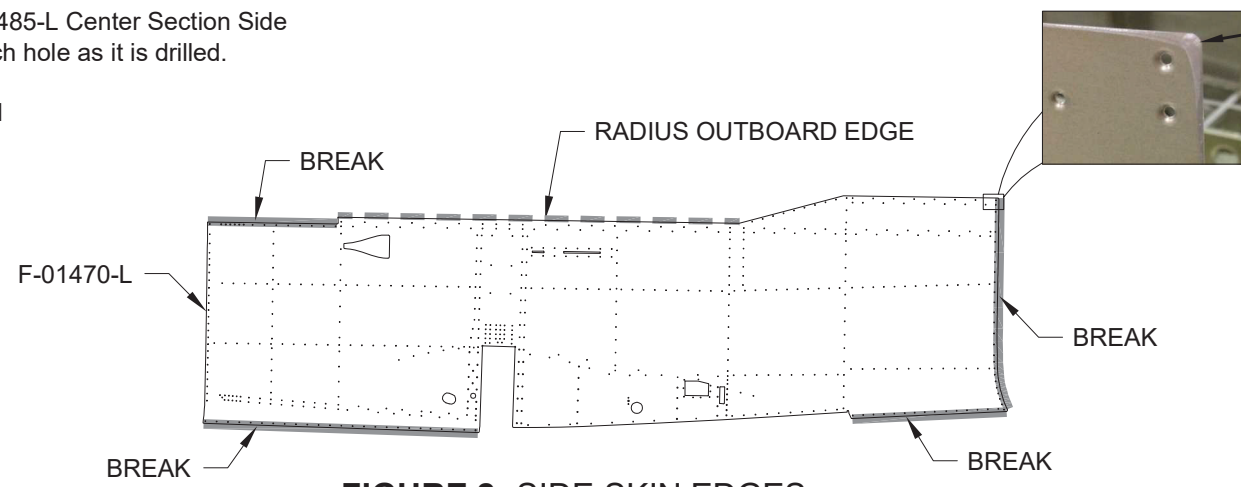

FIGURE 2: SIDE SKIN EDGES

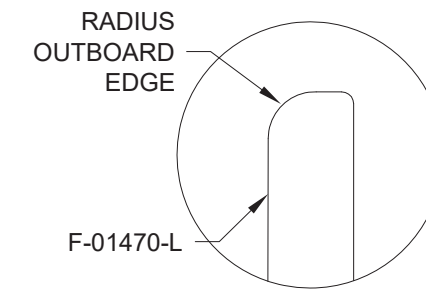

FIGURE 3: SIDE SKIN EDGE RADIUS

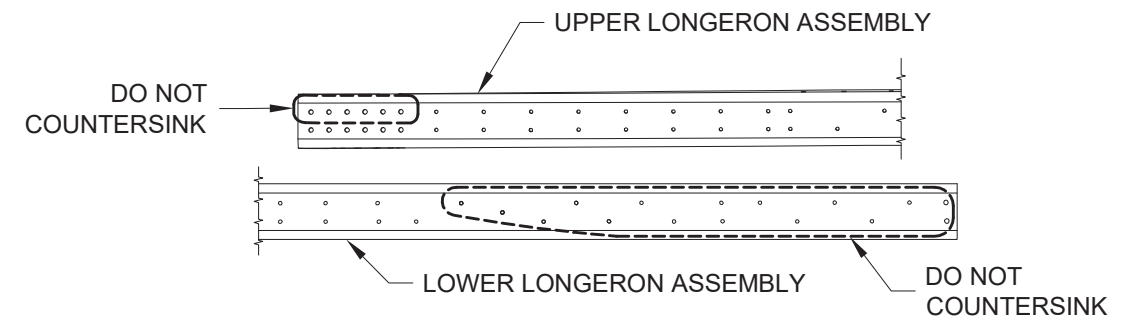

FIGURE 4: LONGERON COUNTERSINKING EXCEPTIONS

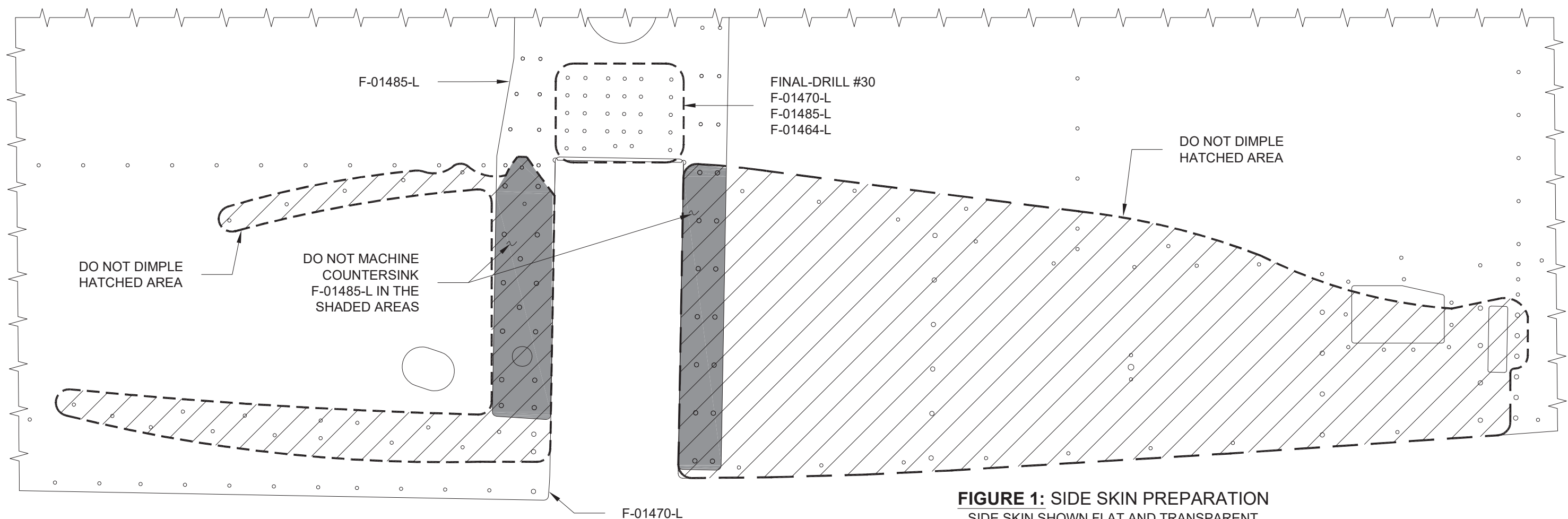

FIGURE 1: SIDE SKIN PREPARATION
SIDE SKIN SHOWN FLAT AND TRANSPARENT



Step 1: Dimple all holes in the flanges of the F-01400A-L & -R, F-01400B-L & -R and the F-01400C-L & -R Skin Stiffeners. See Figure 1.

Step 2: Label and separate the skin stiffeners as shown in Figure 1.

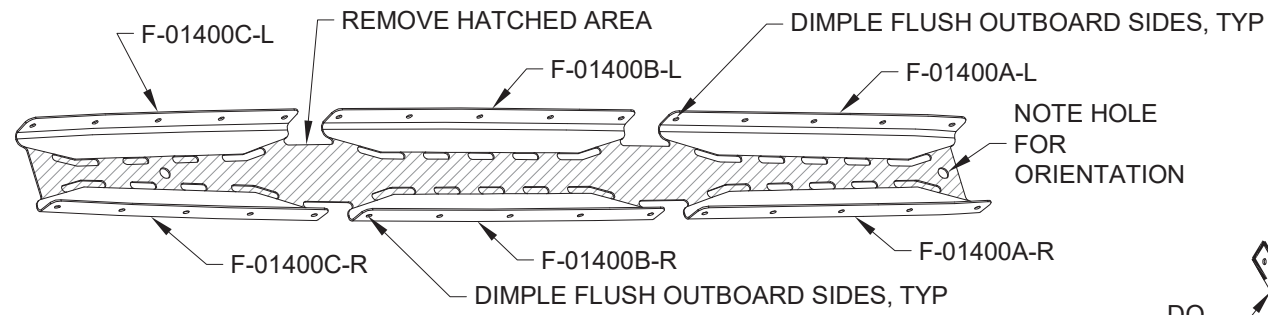

FIGURE 1: SKIN STIFFENERS

NOTE: There is only one set of C-01422 Canopy Latch Brackets.

Step 3: Dimple all holes in the flanges of the C-01422 Canopy Latch Brackets. See Figure 2.

Step 4: Label and separate the canopy latch brackets as shown in Figure 2.

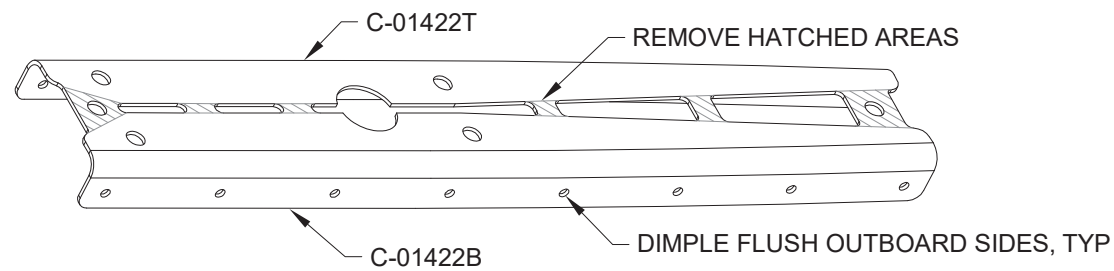

FIGURE 2: CANOPY LATCH BRACKETS

Step 5: Dimple the four holes in the F-01433 Flap Block Brackets shown in Figure 3.

Step 6: Label and separate the flap block brackets as shown in Figure 3.

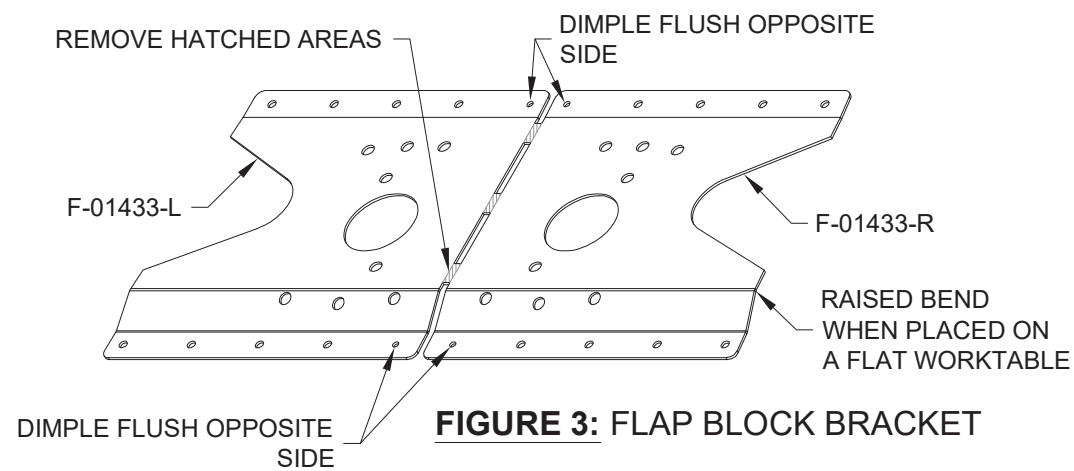

FIGURE 3: FLAP BLOCK BRACKET

Step 7: Dimple all holes in the outboard flanges of the F-01422-L & -R, F-01491-L & -R and F-01492-L & -R Fuselage Side Ribs. See Figure 4.

Step 8: Label and separate the fuselage side ribs as shown in Figure 4.

Step 9: Break the edges of the F-01422-L & -R and F-01491-L & -R Fuselage Side Ribs as indicated in Figure 4.

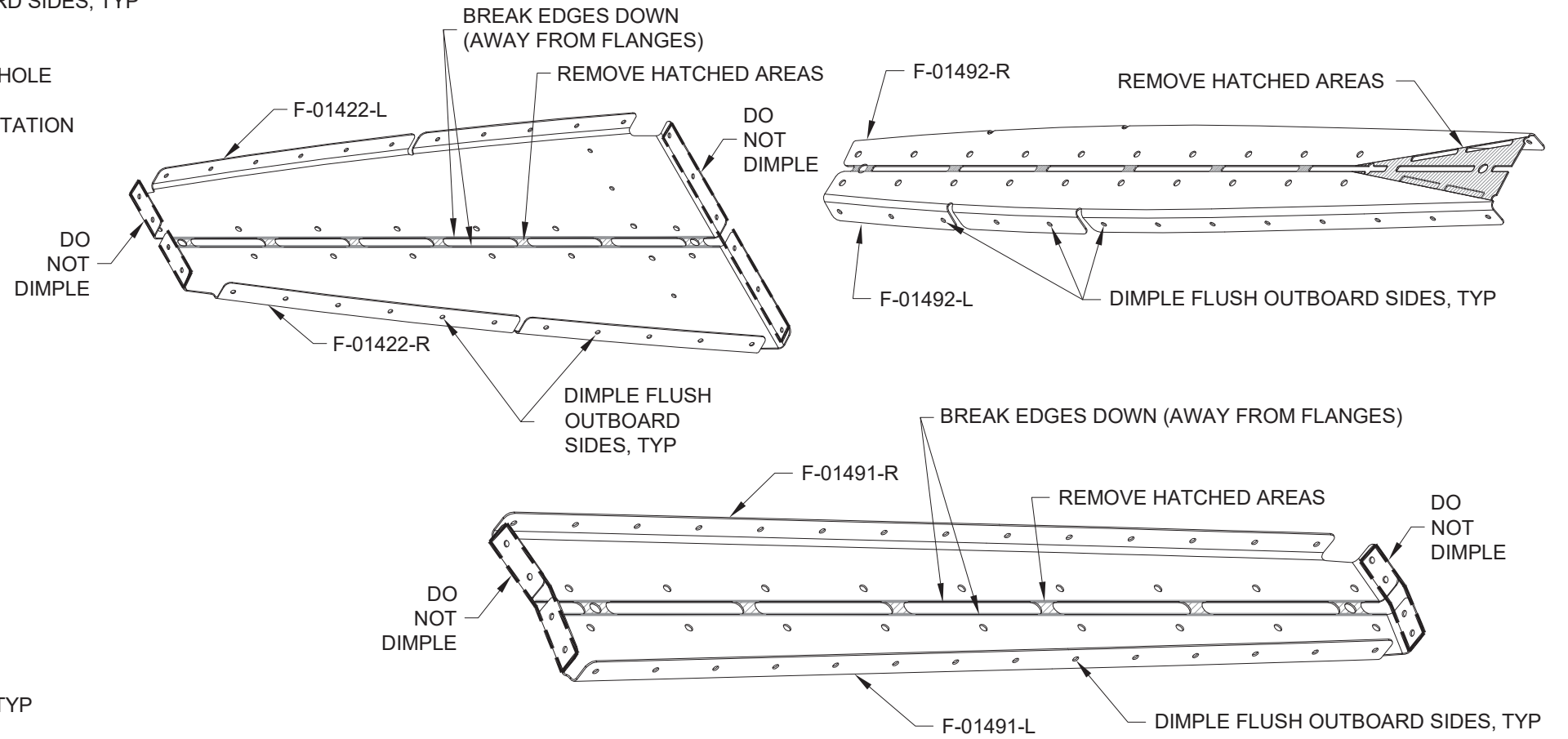

FIGURE 4: FUSELAGE SIDE RIBS

Step 10: Trim the flange of the F-01413-L Stiffener as shown in Figure 5.

Step 11: Dimple the holes in the flange of the stiffener as shown in Figure 5.

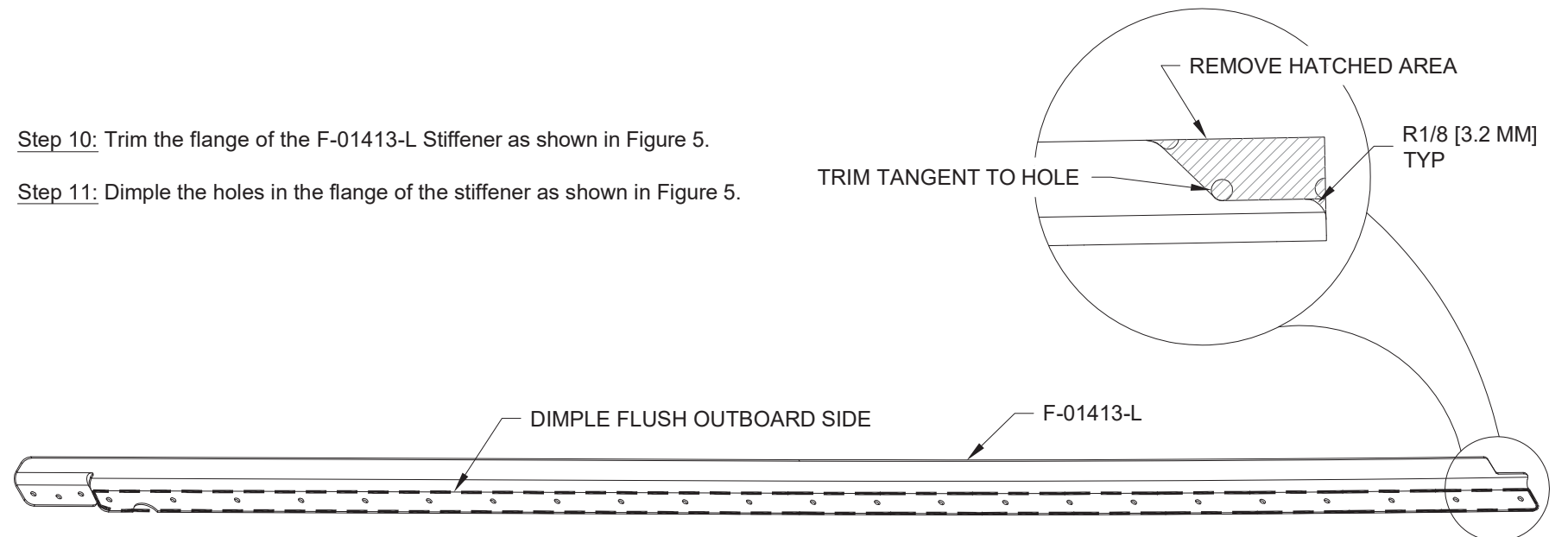
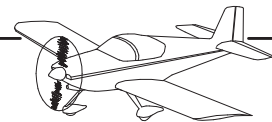

FIGURE 5: STIFFENER



Step 1: Separate the F-01461A-L & -R and F-01461B-L & -R Roll Bar Angles as shown in Figure 1.

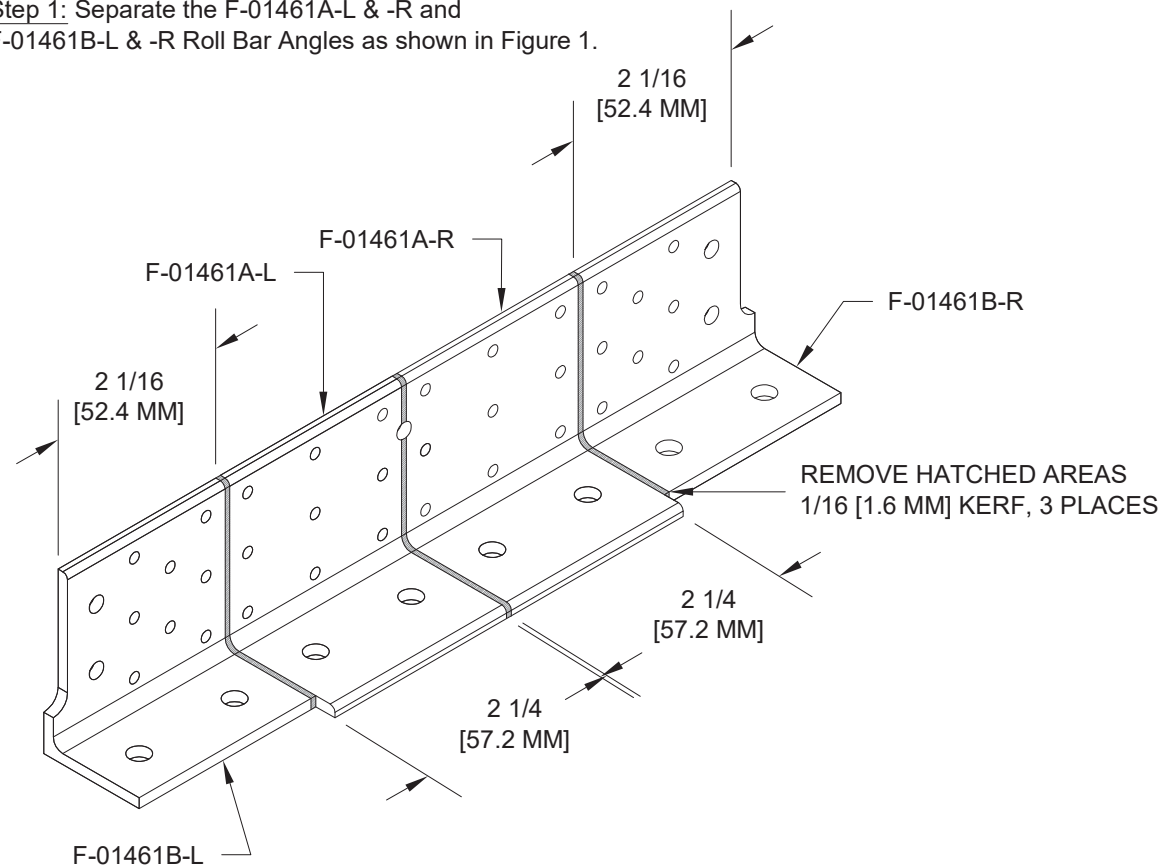

FIGURE 1: ROLL BAR ANGLES

Step 2: Chamfer the F-01461A-L & -R Roll Bar Angles as shown in Figure 2.

Step 3: Prime the F-01461A-L & -R Roll Bar Angles.

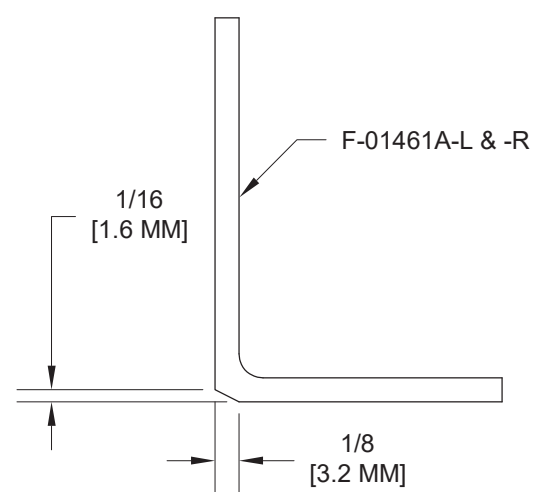

FIGURE 2: ROLL BAR ANGLE CHAMFER

Step 4: Dimple the holes in the outboard flanges of the F-01460-L Intercostal. See Figure 3 for exceptions.

Step 5: Rivet the F-01461B-L Roll Bar Angle to the intercostal as shown in Figure 3.

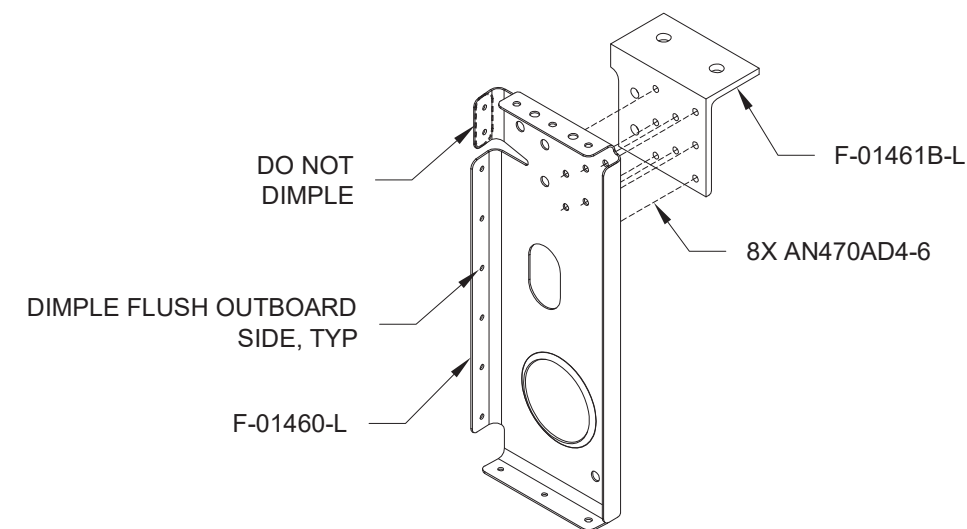

FIGURE 3: INTERCOSTAL

Step 6: Dimple the holes in the F-01420-L Arm Rest as shown in Figure 4.

Step 7: Trim the arm rest as shown in Figure 4.

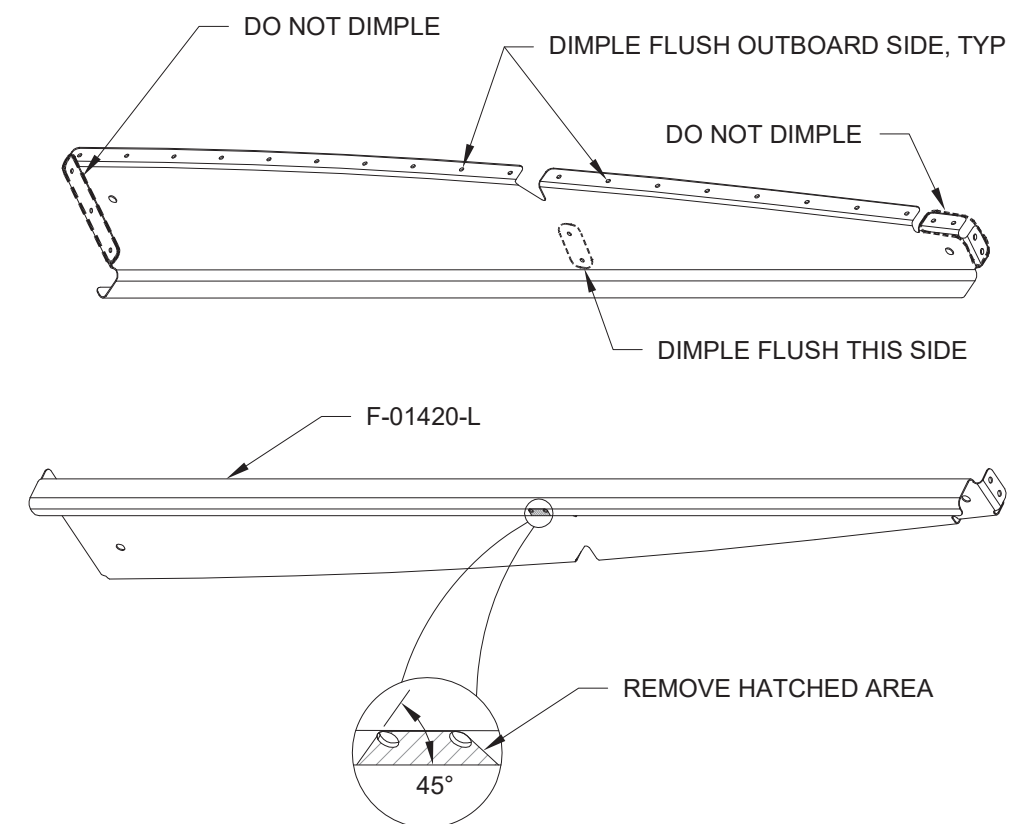

FIGURE 4: ARM REST



Step 1: Cleco the F-01491-L and F-01492-L Fuselage Side Ribs to the fuselage.

Flute the outboard flanges of the side ribs as necessary to align the holes in the flanges with the corresponding holes in the side skin.

Step 2: Rivet the fuselage side ribs to the side skin as shown in Figure 1.

The aft most holes common to the fuselage side ribs and the side skin will be left open for now.

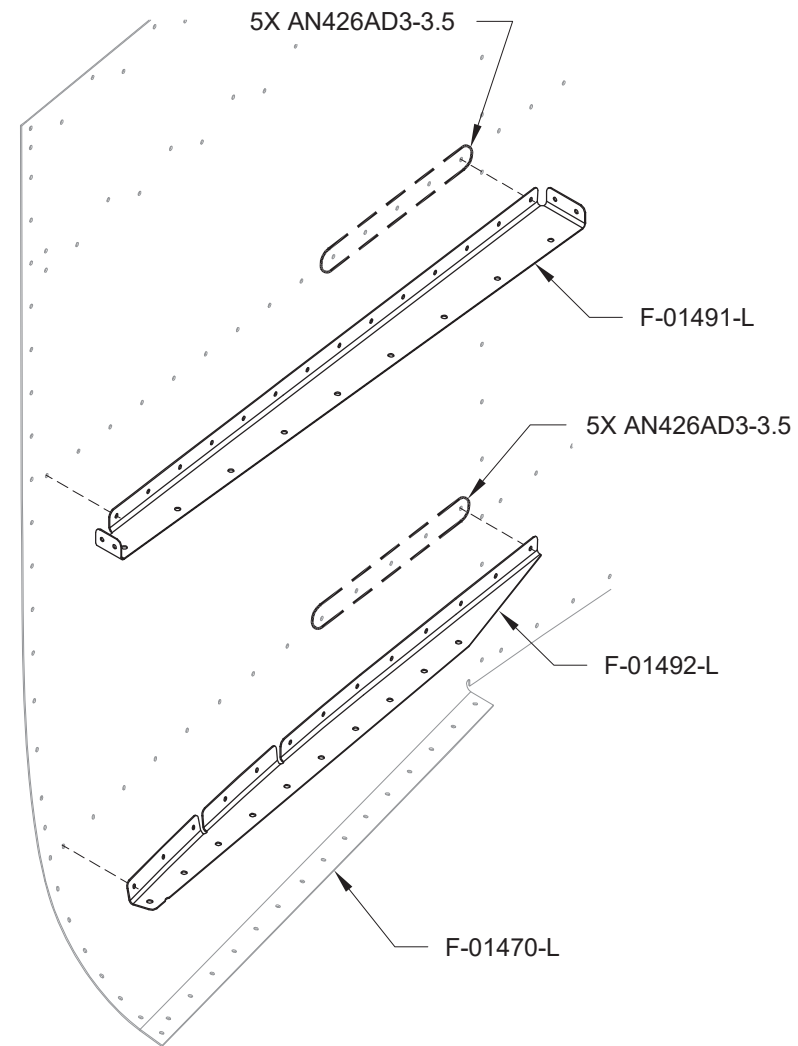

FIGURE 1: FUSELAGE SIDE RIB INSTALLATION

Step 3: Unbolt the F-01464-L Upper Drag Fitting from the fuselage.

Step 4: Cleco and rivet the F-01464-L Upper Drag Fitting, F-01485-L Center Section Side Plate and F-01413-L Stiffener to the side skin as shown in Figure 2.

The aft most holes common to the F-01413-L Stiffener and the side skin will be left open for now.

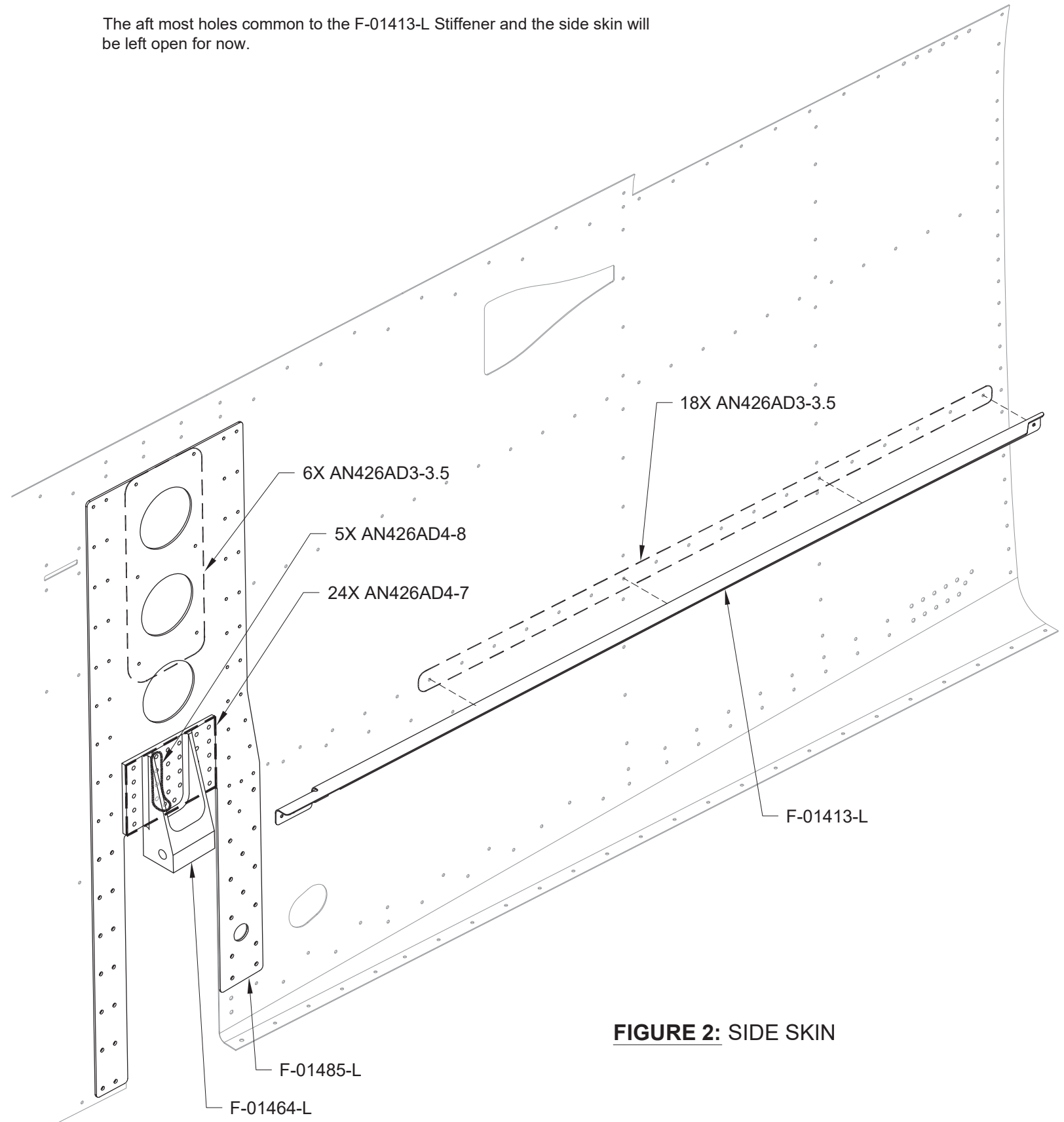
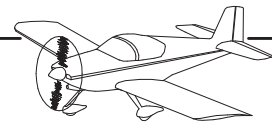

FIGURE 2: SIDE SKIN



Step 1: Rivet the nutplate to the side skin as shown in Figure 1.

Step 2: Temporarily bolt the Lower Longeron Assembly to the firewall. See Figure 1.

Step 3: Rest the side skin on top of the center section as shown in Figure 1. The side skin will be forward and high of the final position

Step 4: Bend the forward portion of the side skin outboard slightly to allow the aft portion of the F-01413 Stiffener to clear inboard of the F-01403D-L Forward Center Section Side Angle, then move the side skin aft to align the center section notch with the center section.

Gently pull the curved lower sections of the side skin outboard and slide the side skin down until it is positioned as shown in Figure 2.

Ensure the F-01491-L and F-01492-L Fuselage Side Ribs are positioned aft of the F-01458-L Side Frame.

Step 5: Cleco the Upper Longeron Assembly to the side skin as shown on Page 29-14, Figure 1.

Step 6: Cleco the side skin to the fuselage beginning at the F-01403 and F-01404 Bulkhead Assemblies and moving aft.

Step 7: Cleco the Lower Longeron Assembly to the side skin as shown in Figure 1.

Step 8: Bolt the F-01464-L Upper Drag Fitting to the fuselage as shown on Page 29-03 Figure 2. Final-Torque the bolt. See Section 5.20 for proper torque values.

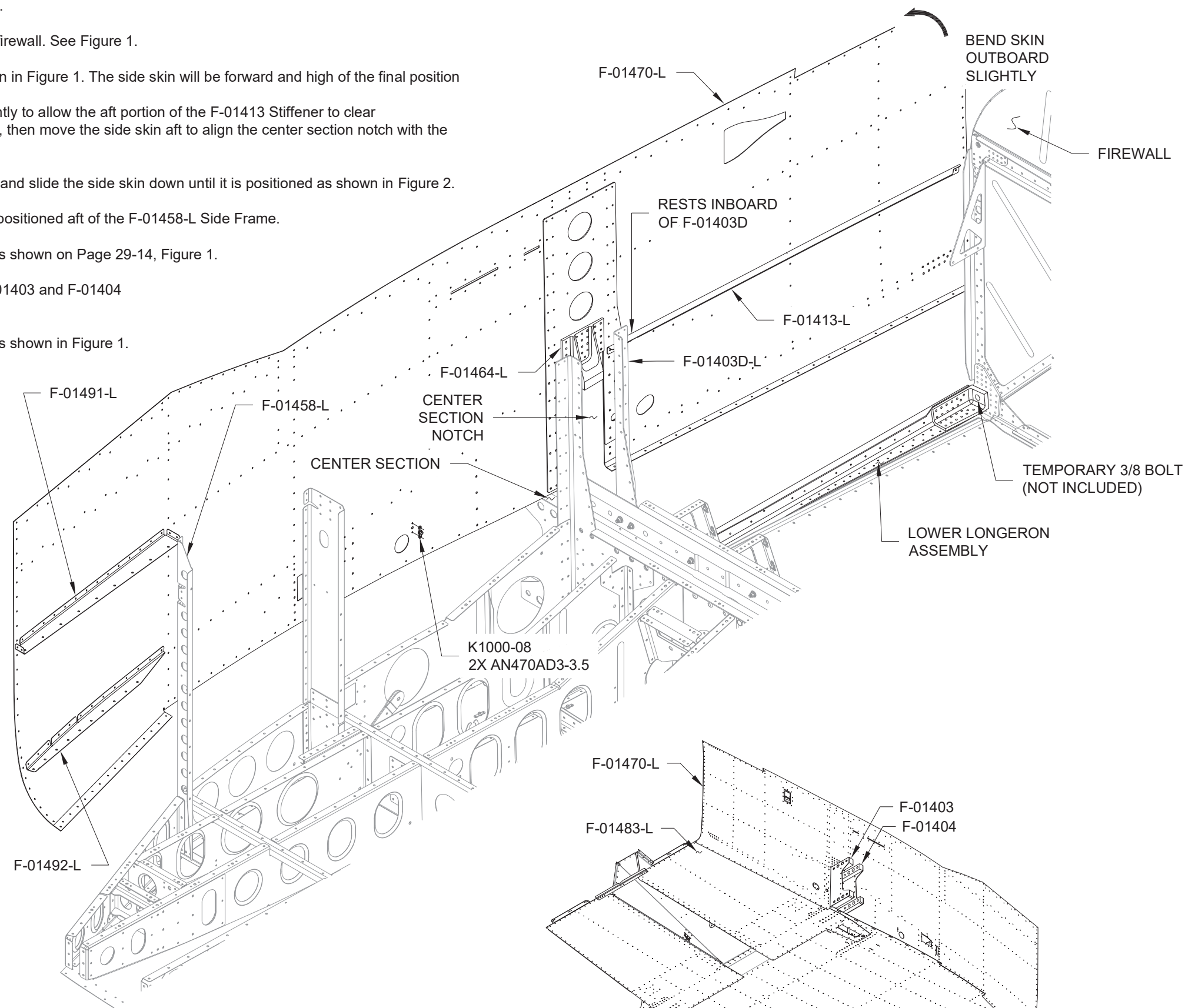

FIGURE 1: SIDE SKIN INSTALLATION

FIGURE 2: SIDE SKIN INSTALLATION (FIREWALL NOT SHOWN)



Step 1: Dimple the holes in the outboard flanges of the F-01428-L Side Frame. See Figure 3 for exceptions.

Dimple the two holes in the horizontal tab of the F-01428-L Side Frame. See Figure 3.

Step 2: Machine Countersink the holes in the outboard flange of the F-01419-L Stiffener. See Figure 2 for exceptions.

Step 3: Temporarily bolt the Upper Longeron Assembly to the firewall.

Step 4: Cleco and rivet the F-01405D-L Bulkhead Side Channel and the C-01422T and C-01422B Canopy Latch Brackets to the side skin as shown on Page 29-16, Figure 1. Flute the outboard flanges as necessary to line up the holes in the flanges with the corresponding holes in the side skin.

Step 5: Cleco the F-01428-L Side Frame, F-01422-L Fuselage Side Rib, F-01419-L Stiffener, and F-01415A-L Seat Rib Angle to the side skin as shown in Figure 1. Flute the outboard flanges as necessary to line up the holes in the flanges with the corresponding holes in the side skin.

Step 6: Cleco the FF-00006B-L Hinge and F-14134B-L Cowling Hinge Shim to the side skin and firewall as shown on Page 29-08, Figure 1.

Step 7: Run a bead of fuel tank sealant between the side skin, firewall and Upper Longeron Assembly prior to riveting in those areas. See Page 29-16, Figure 1. Wipe away any excess fuel tank sealant after riveting.

Step 8: Rivet the side skin to the fuselage, firewall, and all parts clecoed in Step 5 and Step 6. See Page 29-16, Figure 1 for rivet call-outs and exceptions. Back rivet the flush rivets where practical. Begin riveting at the center section and work aft, then forward. Remove bolts as necessary for rivet access, rivet, then reinstall.

Step 9: Rivet the F-01419-L Stiffener 2X AN470AD3-3.5 to the firewall as shown in Figure 1.

Step 10: Rivet the F-01491-L Fuselage Side Rib, F-01458-L Side Frame and F-01422-L Fuselage Side Rib together as shown in Figure 1.

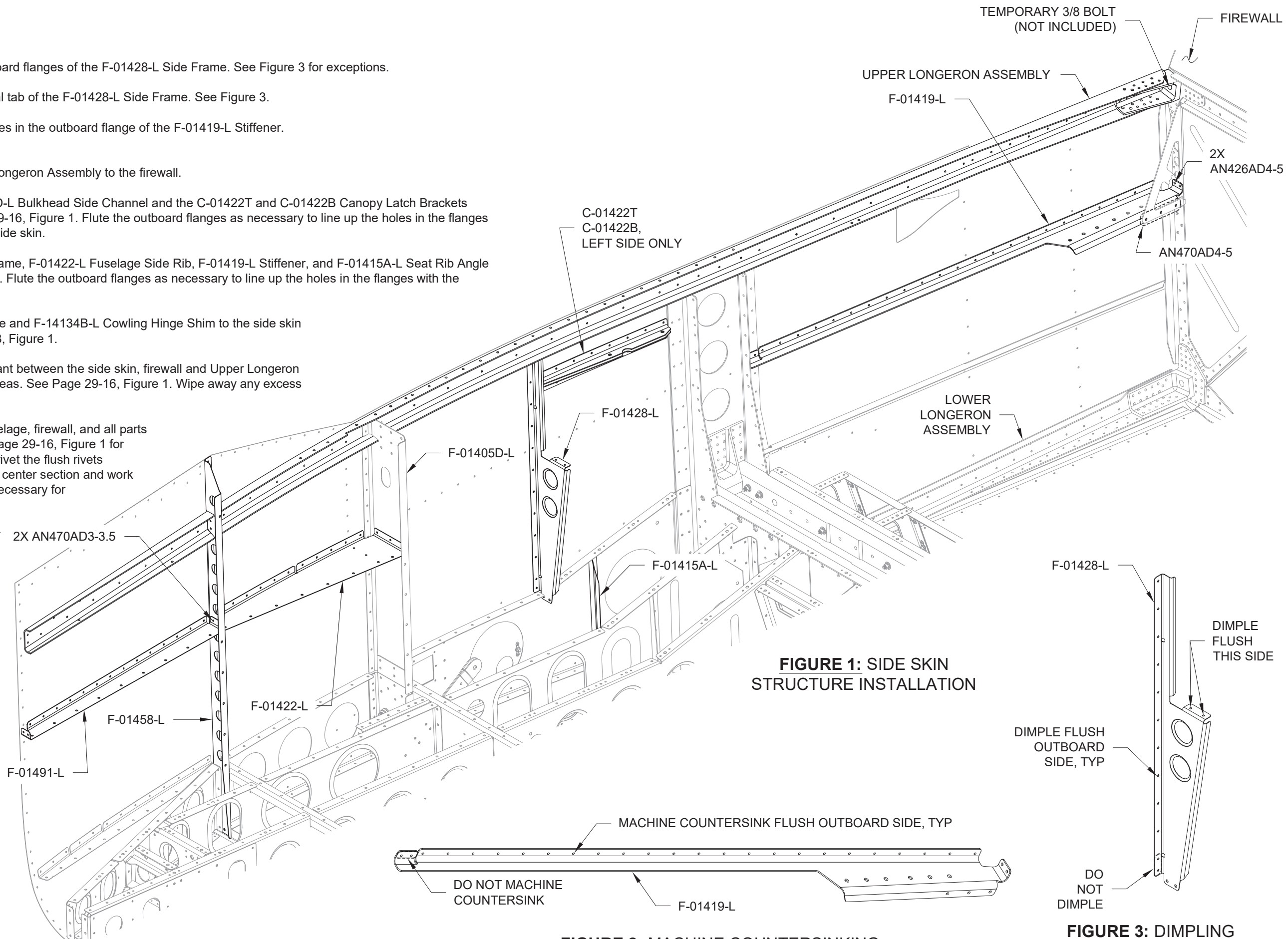

FIGURE 1: SIDE SKIN STRUCTURE INSTALLATION

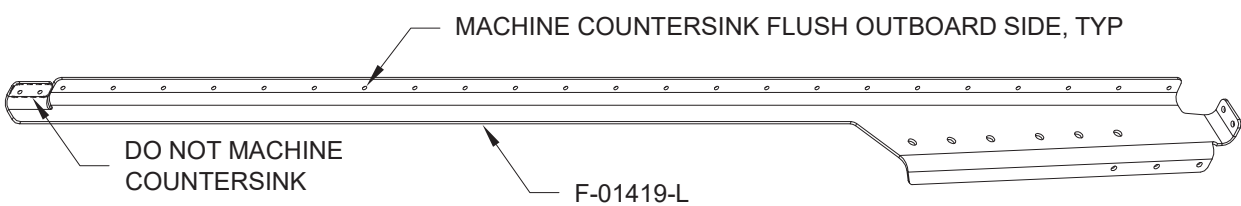

FIGURE 2: MACHINE COUNTERSINKING

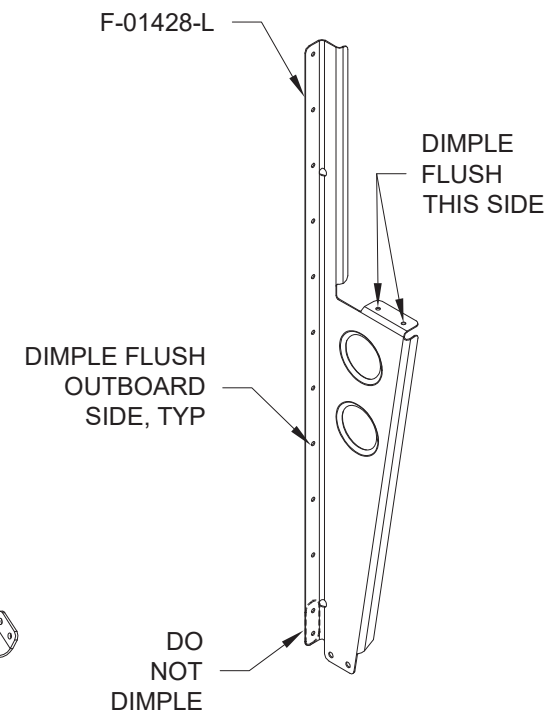

FIGURE 3: DIMPLING

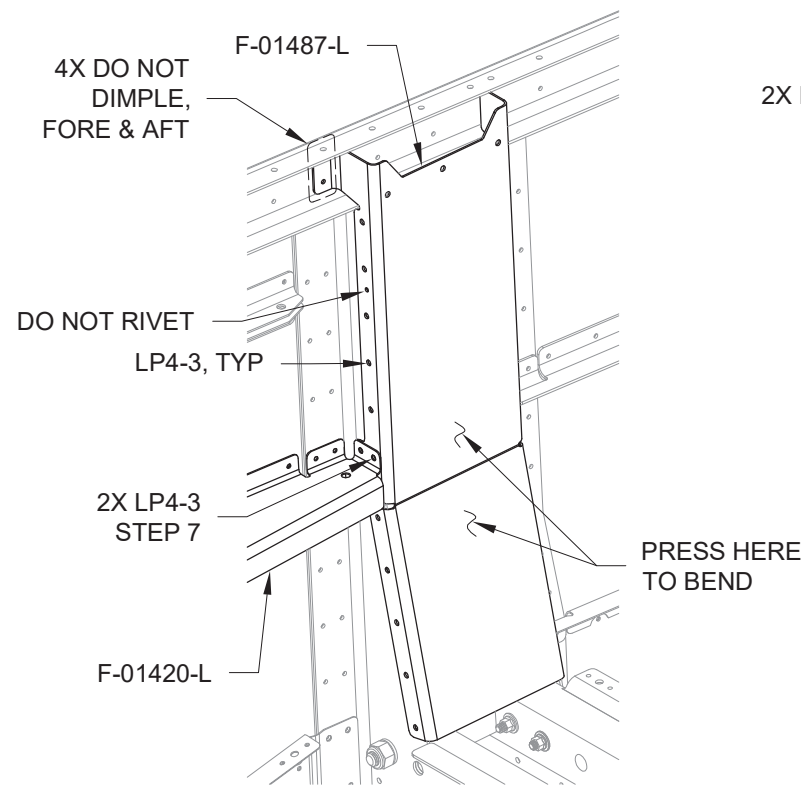
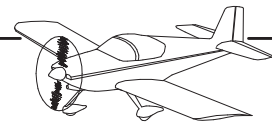

FIGURE 1: CENTER SECTION CHANNEL

Step 1: Bend the F-01487-L Center Section Channel as necessary to match the angle formed by the F-01403D and F-01404D Center Section Angles using the following method:

Align the notches in the forward and aft flanges with the sharp edge of a work table. Press on the web as shown in Figure 1. Avoid exerting force on the flanges of the channel.

Step 2: Cleco and rivet the F-01487-L Center Section Channel to the fuselage as shown in Figure 1. See Page 29-16, Figure 1 for additional rivet callouts and exceptions.

Step 3: Dimple the holes in the outboard flanges of the F-01402-L Side Frame. See Figure 2.

Step 4: Cleco and rivet the F-01420-L Arm Rest, F-01402-L Side Frame, and the F-01400A, F-01400B and F-01400C Stiffeners to the side skin as shown in Figure 2. See Page 29-16, Figure 1 for rivet call-outs. Flute the outboard flanges as necessary to line up the holes in the flanges with the corresponding holes in the side skin.

Step 5: Rivet the F-01402-L Side Frame to the Upper and Lower Longeron Assemblies. See Page 29-16, Figure 1 for rivet callouts.

Step 6: Rivet the F-01420-L Arm Rest to the F-01428-L Side Frame as shown in Figure 2.

Step 7: Rivet the F-01420-L Arm Rest to the F-01487-L Center Section Channel as shown in Figure 1.

Step 8: Rivet the F-01461A-L Roll Bar Angle to the aft side F-01405D-L Bulkhead Side Channel in the three locations shown in Figure 2.

Step 9: Rivet the F-01422-L Fuselage Side Rib to the F-01405D-L Bulkhead Side Channel and F-01420-L Arm Rest as shown in Figure 2.

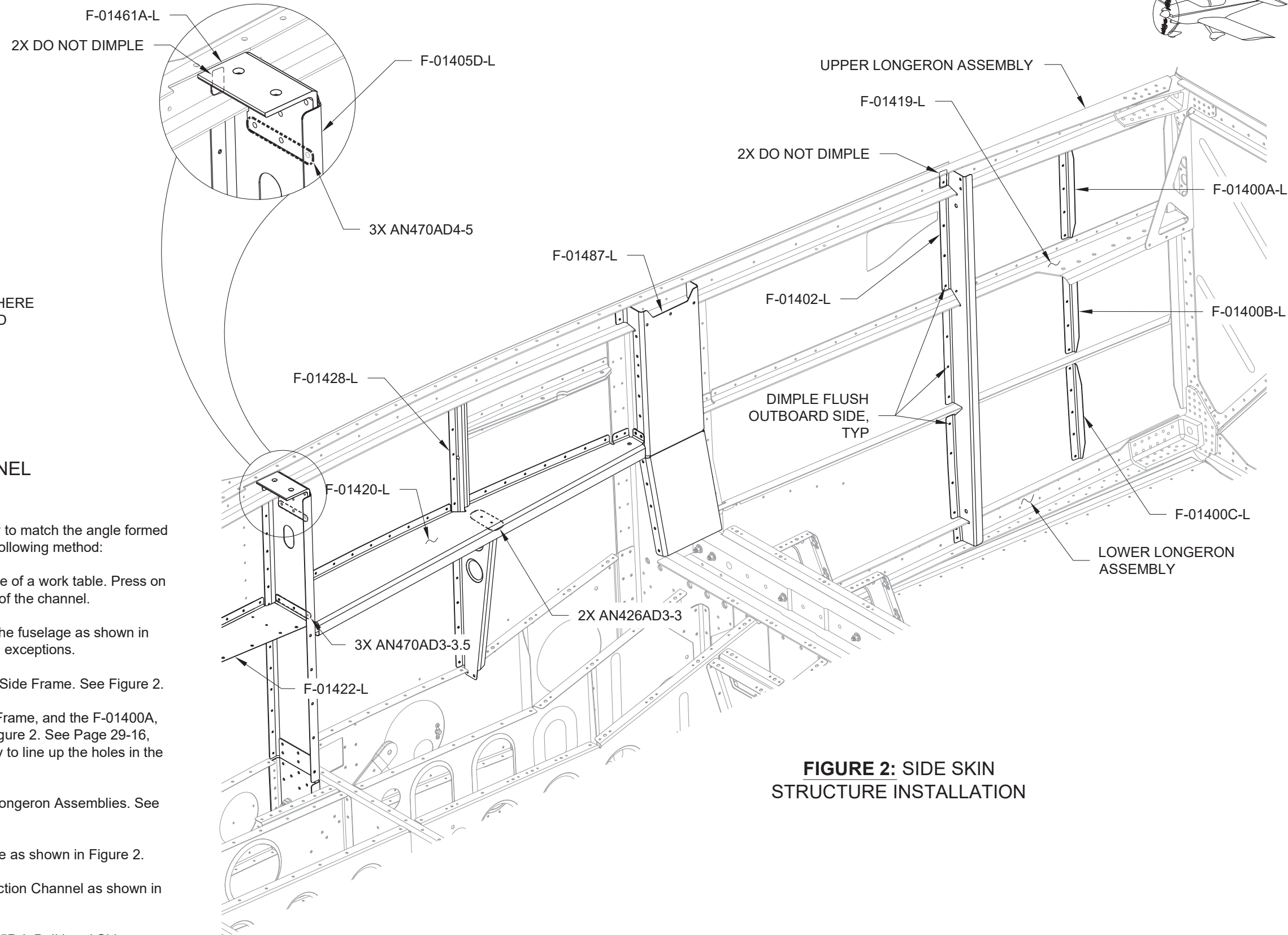

FIGURE 2: SIDE SKIN STRUCTURE INSTALLATION



NOTE: The side skin must be riveted to the fuselage prior to the installation of the F-01433-L Flap Block Bracket.

Step 1: Cleco the F-01433-L Flap Block Bracket to the inside of the fuselage as shown in Figure 1.

Step 2: Rivet the flap block bracket to the fuselage as shown in Figure 2.

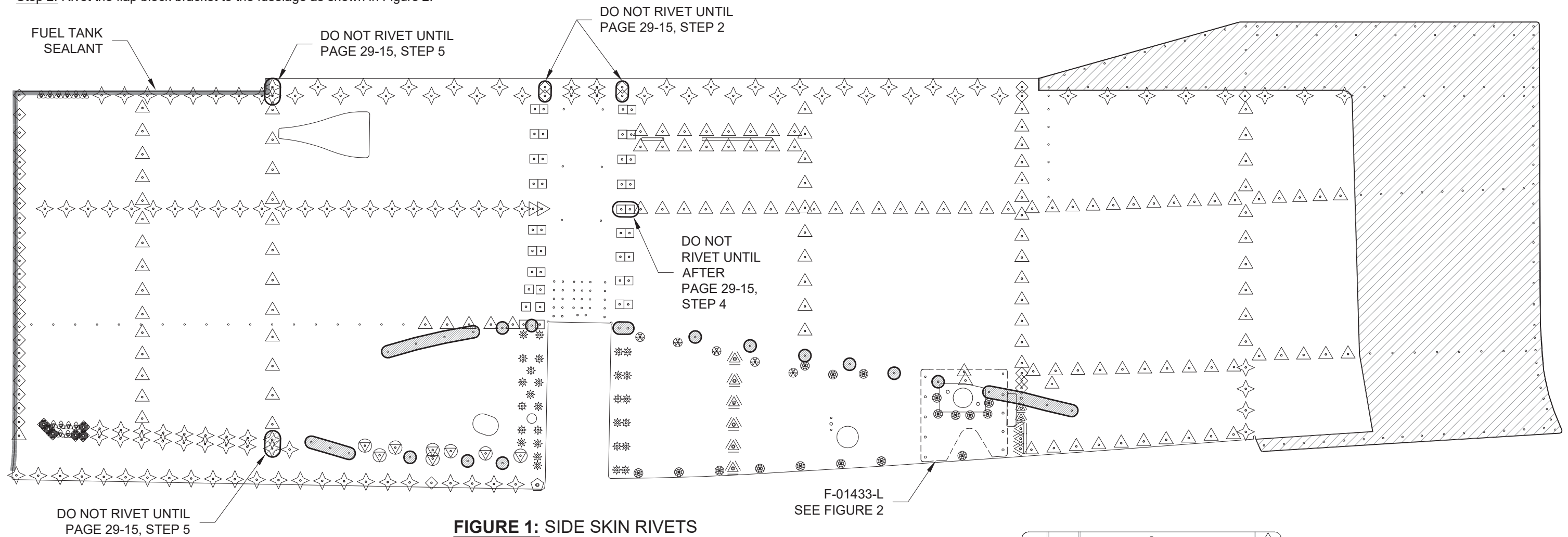

FIGURE 1: SIDE SKIN RIVETS

- | | | | |
|--|--------------|--|--------------|
| | AN470AD3-3 | | AN426AD3-3.5 |
| | AN470AD3-3.5 | | AN426AD3-4 |
| | AN470AD3-4 | | AN426AD3-4.5 |
| | AN470AD4-5 | | AN426AD3-5 |
| | AN470AD4-6 | | AN426AD3-6 |
| | CR3212-4-5 | | AN426AD4-5 |
| | DO NOT RIVET | | AN426AD4-6 |
| | | | AN426AD4-7 |

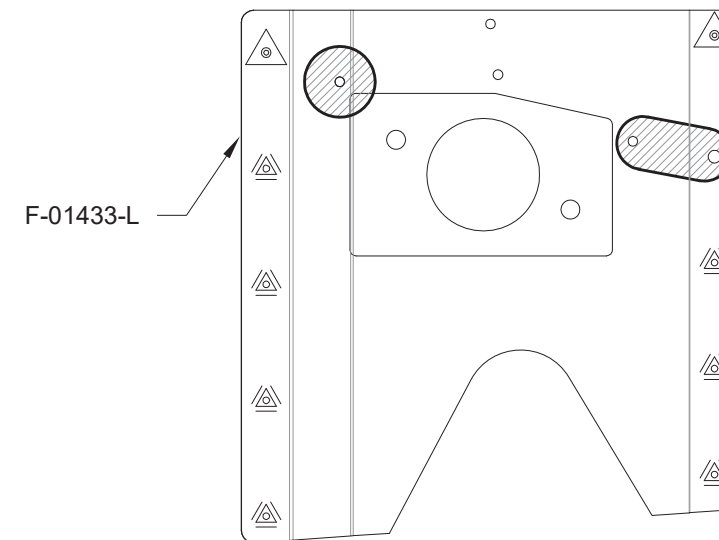
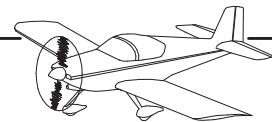

FIGURE 2: FLAP BLOCK BRACKET RIVETS



Step 1: Final-Drill #17 the holes in the flanges of the F-14119-L & -R and F-14120-L & -R Root Fairing Attach Angles.
See Figure 1 and Figure 2. Deburr the holes thoroughly before proceeding.

Step 2: Dimple the #17 Holes in the F-14119 and F-14120 Root Fairing Attach Angles as shown in Figure 1 and Figure 2.

Step 3: Dimple the #40 holes in the flanges of the F-14119-L & -R and F-14120 -L & -R Root Fairing Attach Angles.
See Figure 1, Figure 2 and Page 29-18, Figure 2 for orientation.

Step 4: Trim flanges of the the F-14120-L & -R Root Fairing Attach Angles as shown in Figure 2.

Step 5: Label and separate the F-14119-L & -R, F-14120-L & -R and F-14121-L & -R Root Fairing Attach Angles as shown in Figure 1 and Figure 2.

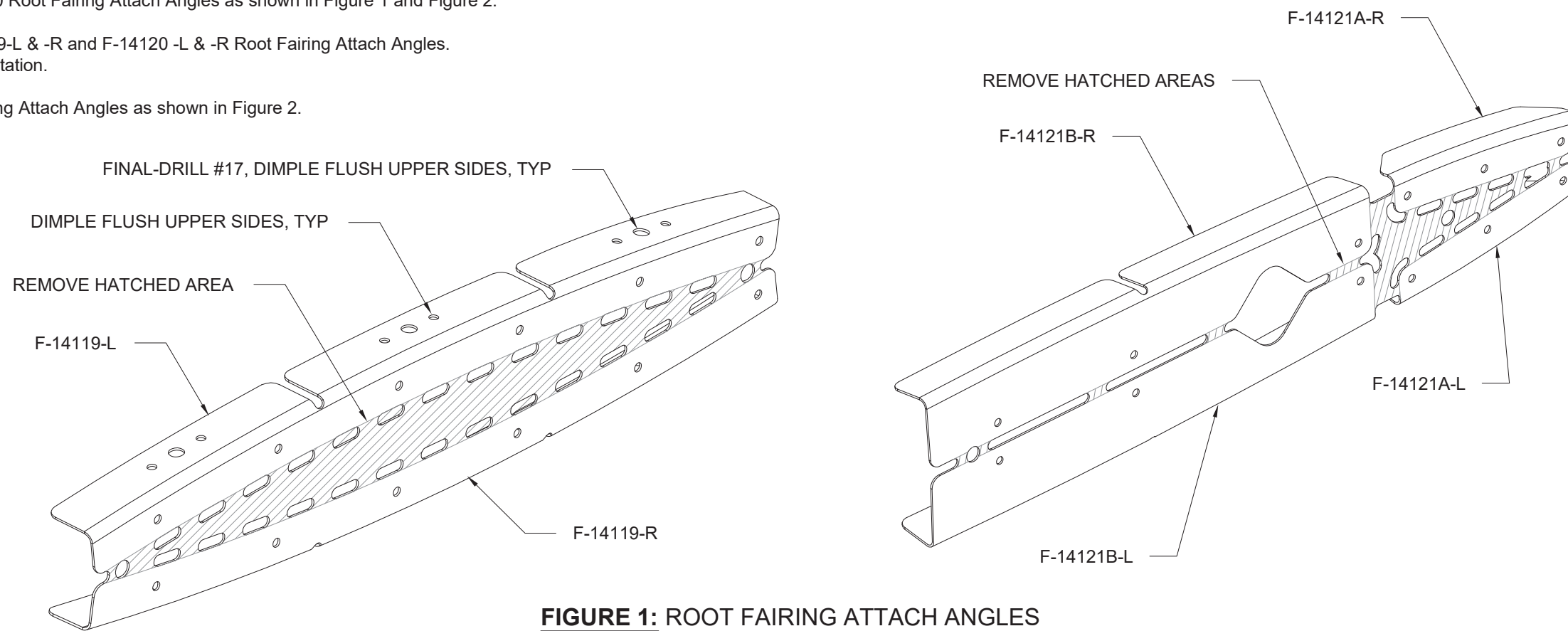
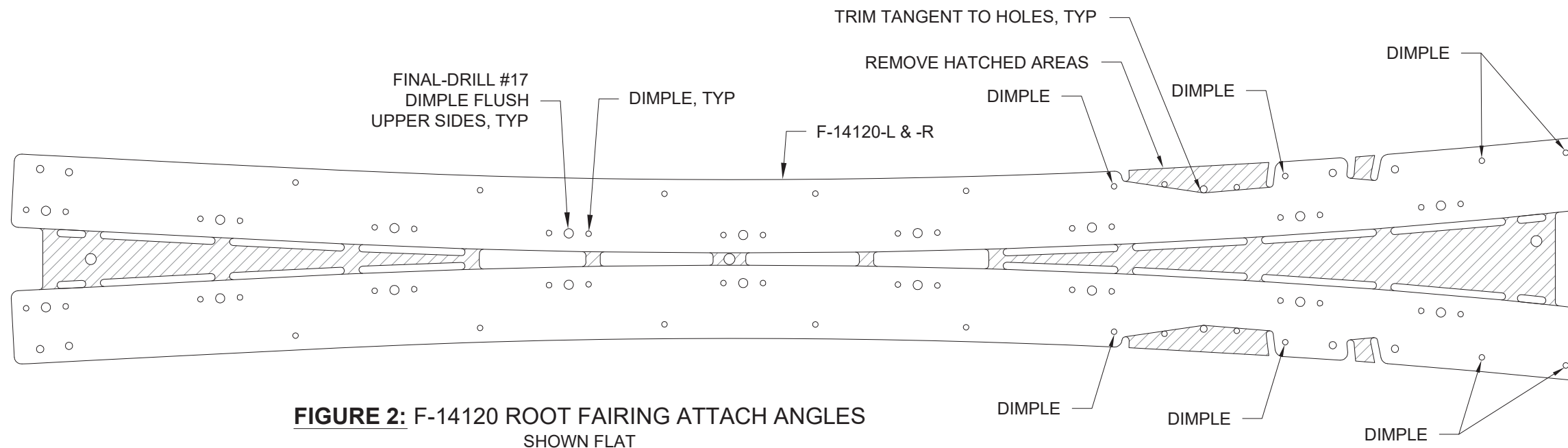

FIGURE 1: ROOT FAIRING ATTACH ANGLES



**FIGURE 2: F-14120 ROOT FAIRING ATTACH ANGLES
SHOWN FLAT**



Step 1: Separate the F-01463 Web Stiffeners. See Figure 1 for reference.

Step 2: Rivet the F-01463 Web Stiffeners to the F-01403 and F-01404 Bulkhead Assemblies as shown in Figure 1.

Step 3: Rivet the nutplates to the F-01484 Bottom Skin as shown in Figure 2. Note that one nutplate is installed between the F-01404 and F-01403 Bulkhead Assemblies.

Step 4: Rivet the seven nutplates to the F-14120-L Root Fairing Attach Angle as shown in Figure 1.

Step 5: Rivet the three nutplates to the F-14119-L Root Fairing Attach Angle as shown in Figure 1.

Step 6: Use temporary rivets in the two forward most holes in the F-14120-L Root Fairing Attach Angle as alignment pins while fluting the **vertical** flanges of the F-14120-L Root Fairing Attach Angles as necessary align the holes in the flange with the holes in the side skin. Work from the forward end and move aft, fluting as required. See Figure 3 for suggested fluting locations.

Step 7: The F-14121A & B Root Fairing Attach Angle will have nutplates match-drilled and installed in a later section. The F-14121B Root Fairing Attach Angle does not require fluting. Flutes in the F-14121A Root Fairing Attach Angle must not intrude into the nutplate location.

Flute the **horizontal** flange of the F-14121A Root Fairing Attach Angle as necessary to lay the flange flat against the fuselage. See Figure 2 for acceptable fluting locations.

Step 8: Rivet the root fairing attach angles to the fuselage as shown in Figure 1. Rivet all angles from forward to aft.

Step 9: Rivet the remaining nutplates to the F-14120-L Root Fairing Attach Angle as shown in Figure 1.

Step 10: Reinstall the F-01405B Bulkhead Bar Assemblies as shown on Page 25-02, Figure 1. Fully torque the nuts. See Section 5.20 for proper torque values.

Step 11: Reinstall and fully torque the bolts in the fuselage as shown on Page 29-03, Figure 1 and Figure 2. See Section 5.20 for proper torque values.

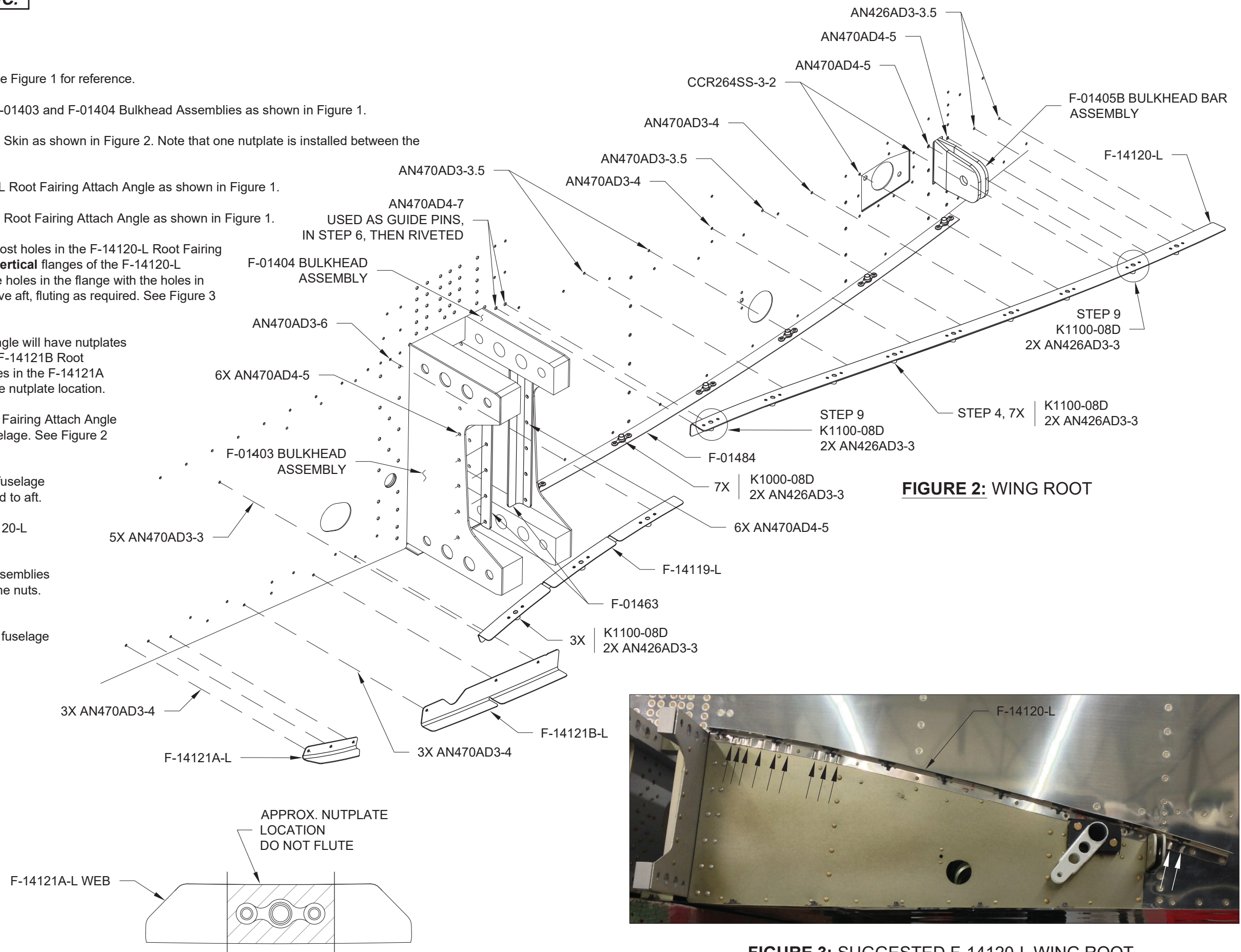

FIGURE 2: WING ROOT

FIGURE 1: WING ROOT FAIRING ATTACH ANGLE FLUTING ANGLE SHOWN BENT TO APPROXIMATE PART CURVATURE

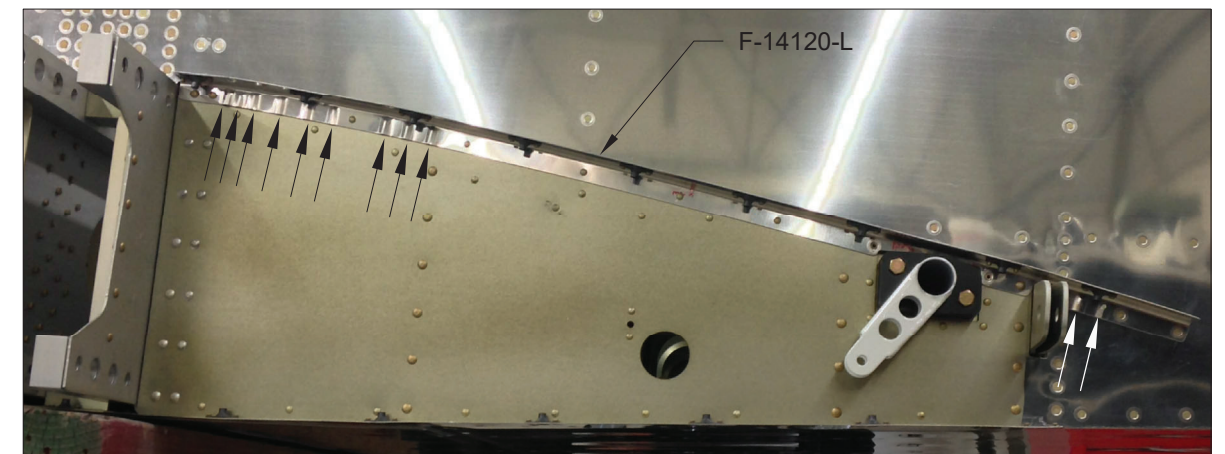

FIGURE 3: SUGGESTED F-14120-L WING ROOT FAIRING FLUTING

7C
6
1C
6
1E
2
2E
4
4
14
24



NOTE: Complete the previous steps in this section for each side of the aircraft before continuing.

Step 1: Separate four F-01405N Seat Back Adjustment Guides as shown in Figure 1.

Radius the corners of the seat back adjustment guides as shown in Figure 1.

Step 2: Machine countersink the #40 holes on the forward side of the F-01405F-1 Brace to fit the head of an AN426AD3 rivet. See Figure 2.

Step 3: Rivet the nutplates to the F-01405F-1 Brace as shown in Figure 2.

Step 4: Separate the F-01405K Guides, F-01405H Shims and F-01405J Angles. See Figure 2 for part reference.

Step 5: Machine Countersink the holes in the F-01405H Shims. See Figure 2.

Step 6: Dimple the holes in the F-01405K Guides.

Step 7: Rivet the shims, angles and guides to the F-01405F-1 Brace as shown in Figure 2.

Step 8: Attach the F-14144 Seatback Guides to the brace as shown in Figure 2.

Step 9: Clamp the F-01405N Seat Back Adjustment Guides to the brace. Set one edge flush with the forward edge of the F-01405K Guides. See Figure 2.

Step 10: Match-Drill #30 the holes in the F-01405F-1 Brace into the F-01405N Seat Back Adjustment Guides as shown in Figure 2.

Step 11: Machine countersink the holes in the seat back adjustment guides to fit the head of an AACQ-4-4 (Use a 100° machine countersink cutter with a #30 pilot).

Step 12: Rivet the seat back adjustment guides to the brace as shown in Figure 2.

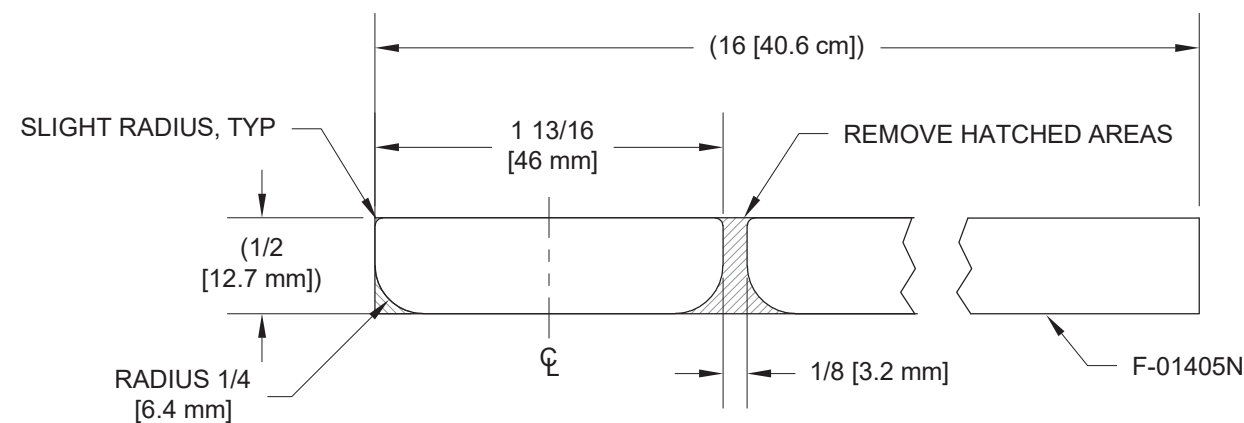

FIGURE 1: F-01405N SEAT BACK ADJUSTMENT GUIDES

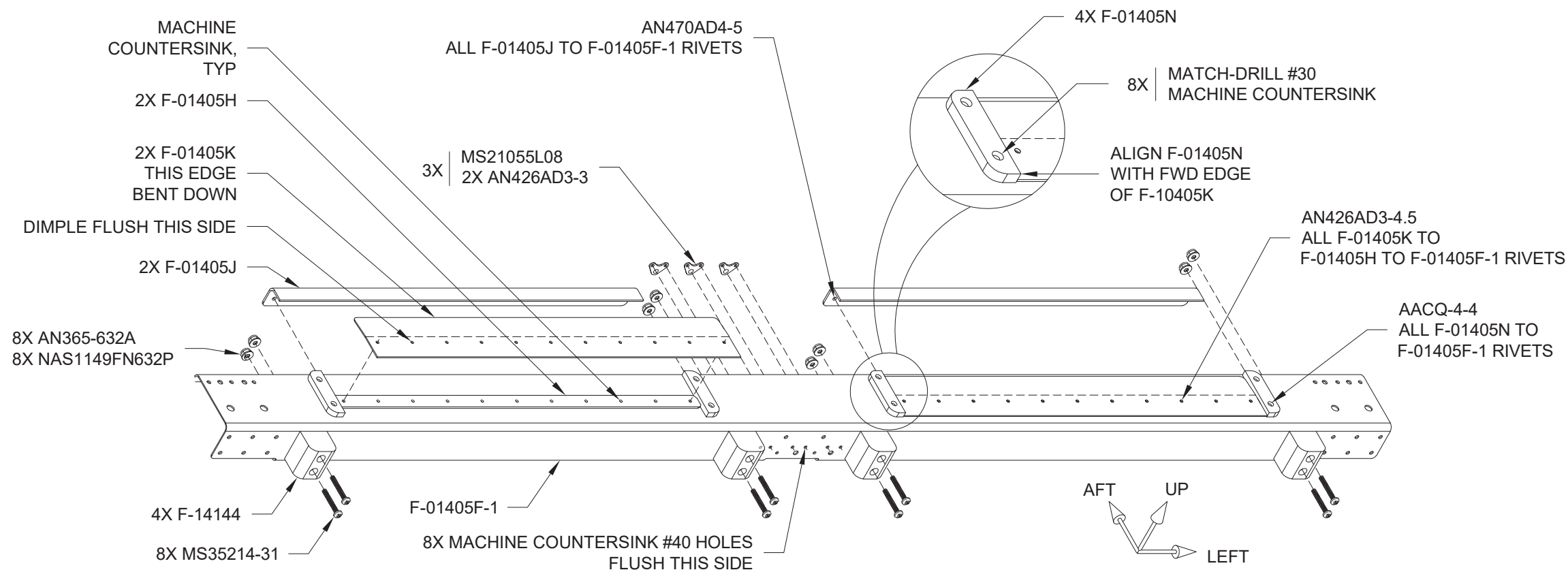

FIGURE 2: BRACE

Step 1: Cleco the #40 hole in the F-14204-L & -R Gussets to the Upper Longeron Assemblies. Rotate the gussets to overlap the outboard edge over the top edge of the side skins as shown in Figure 1.

Clamp the gussets to the Upper Longeron Assemblies.

Step 2: Final-Drill #30 and cleco the outboard holes in the gussets into the Upper Longeron Assemblies. Begin drilling at the match-drill call-out, then final-drill the remaining holes, leaving the aft most hole for last. See Figure 1.

Step 3: Final-Drill 1/4 [6.4 mm] the two holes common to the F-01461A-L & -R Roll Bar Angles, F-14204-L & -R Gussets, and F-01405D Bulkhead Side Channel. See Figure 1.

Step 4: Remove the gussets from the fuselage.

Step 5: Machine countersink the holes in the F-14204-L & -R Gussets as shown in Figure 2.

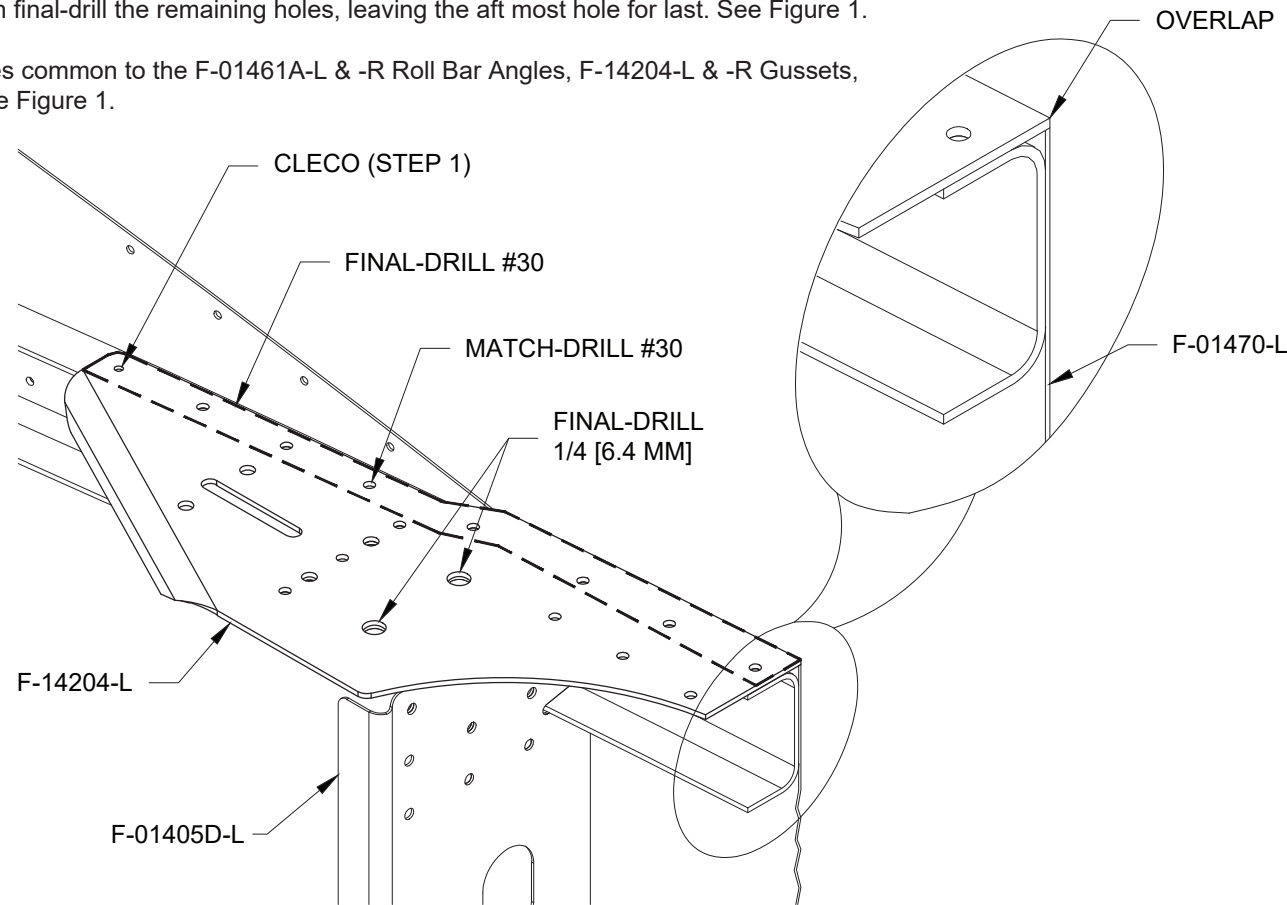

FIGURE 1: MATCH-DRILL GUSSET

Step 6: Cleco and rivet the F-01405F-1 Brace to the F-01405D-L & -R Bulkhead Side Channels as shown in Figure 3.

Step 7: Cleco, temporarily bolt, and rivet the F-14204-L & -R Gussets to the Upper Longeron Assemblies. See Figure 1, Figure 2, and Page 29-21, Figure 1.

Step 8: Remove the temporary bolts and slide the F-01460-L & -R Intercostals outboard under the F-01405F-1 Brace and F-01461A-L & -R Roll Bar Angles as shown in Figure 4.

Step 9: Cleco and rivet the F-01460-L & -R Intercostals to the Upper Longeron Assemblies and side skins as shown in Figure 4.

Step 10: Rivet the F-01460-L & -R Intercostals to the F-14204-L & -R Gussets using the rivets called-out in Figure 2.

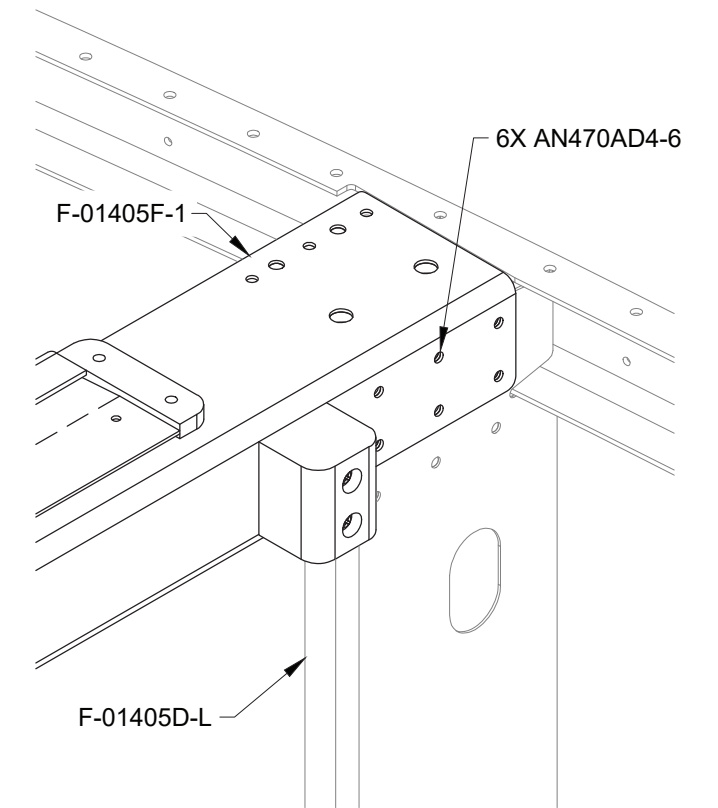

FIGURE 3: BRACE INSTALLATION

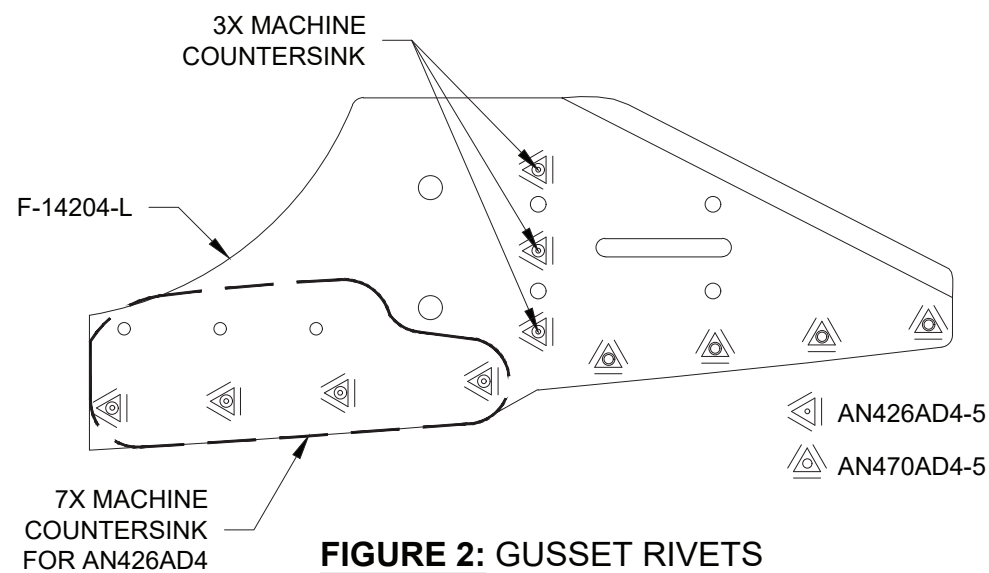

FIGURE 2: GUSSET RIVETS

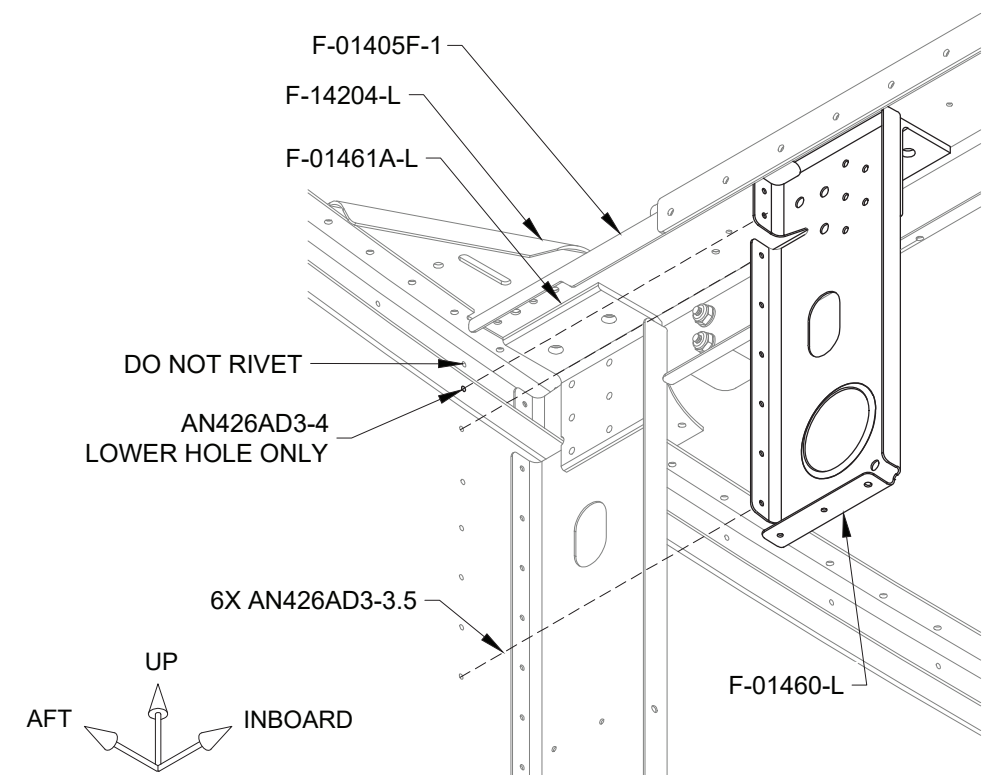
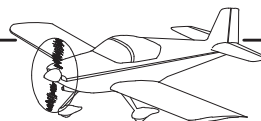

FIGURE 4: INTERCOSTAL INSTALLATION
F-01422-L NOT SHOWN



Step 1: Bolt the F-1231D Roll Bar Bases to the fuselage as shown in Figure 1. See Section 5.20 for proper torque values.

Step 2: Rivet the F-01460-L & -R Intercostals to the F-01422-L & -R Fuselage Side Ribs as shown in Figure 1.

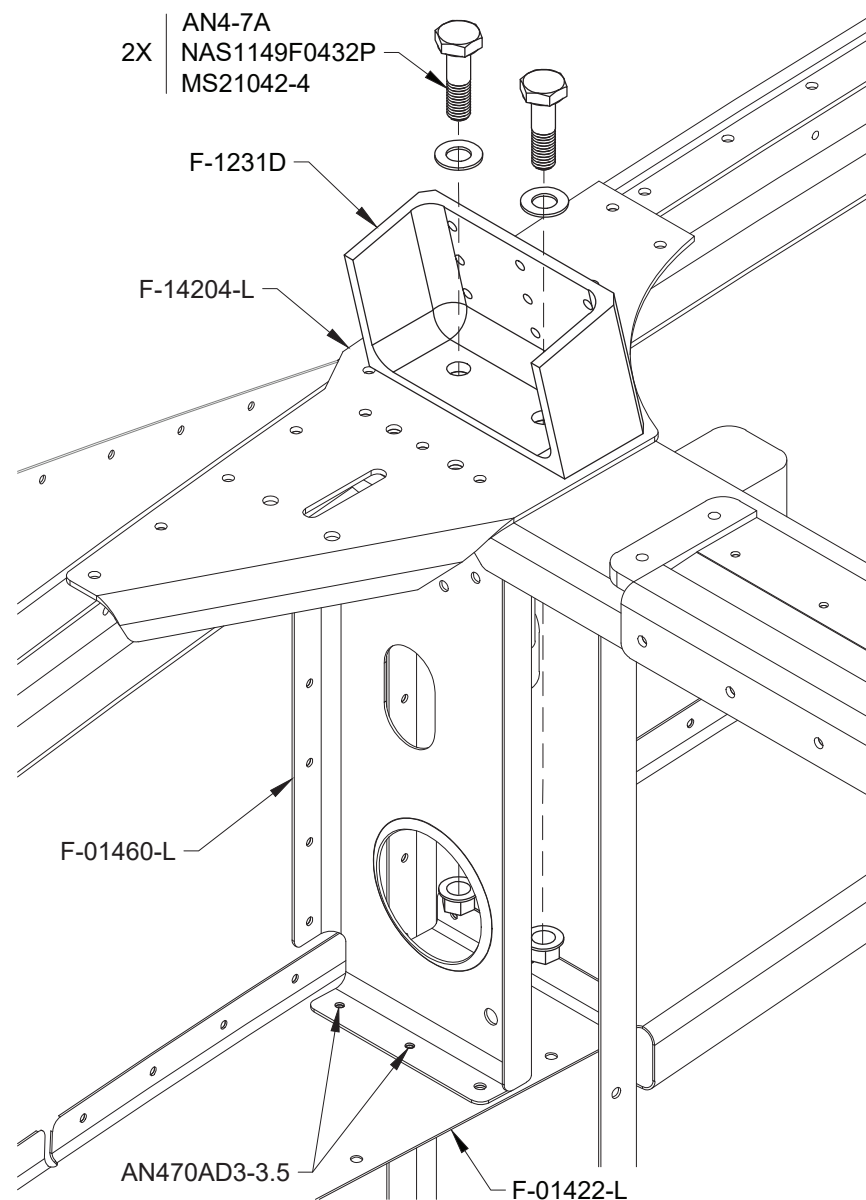

FIGURE 1: ROLL BAR BASE INSTALLATION

Step 3: Separate the F-14186-L & -R NACA Vent Brackets as shown in Figure 2.

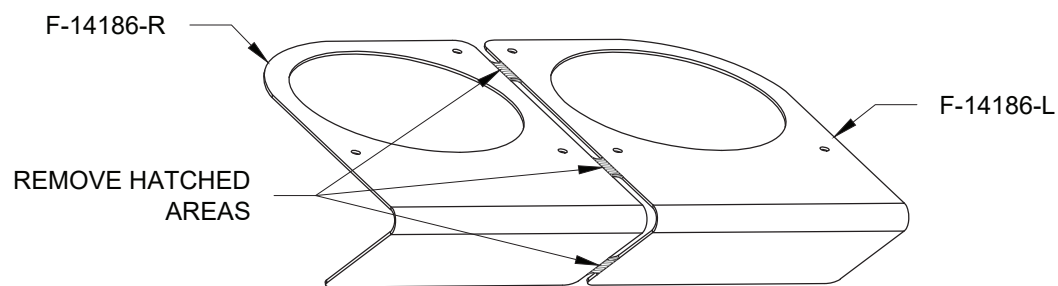

FIGURE 2: VENT BRACKET SEPARATION

NOTE: VENT SV-6 or VENT SV-7 Fresh Air Vent/Nozzle are not included in the kit. Please see Van's Aircraft web store to purchase the vents of your choice.

Step 4: File the inside of the 2 1/2 [63.5 mm] hole in the F-14186-L NACA Vent Bracket to approximately 2.6 [66 mm] or until the bracket can rest on the flange of the VENT SV-6 or VENT SV-7 without limiting movement of the vent nozzle. See Figure 4.

Step 5: Use a belt sander to trim the VENT SV-10 Fresh Air Vent as shown in Figure 3.

Step 6: Sand the aft face of the SV-10-L Vent Fresh Air until it is flat. See Figure 4.

NOTE: Scuff until no shiny areas remain.

Step 7: Scuff the outboard face of the Vent-SV-10-L Fresh Air Vent, as well as inside the chamfered perimeter inside the hole the aft flange. See Figure 4.

Step 8: Scuff the interior and exterior surfaces of the duct that will be painted. Painting may occur at any time after Step 3 on page 29-22, but do not paint any bonding surfaces.

Step 9: Scuff the forward side of the flange of the VENT SV-6 or VENT SV-7. See Figure 4.

Step 10: Scuff the outboard face of the F-14186-L NACA Vent Bracket.

Step 11: Clamp the Air Vent Assembly together as shown in Figure 4. Position the clamps inboard.

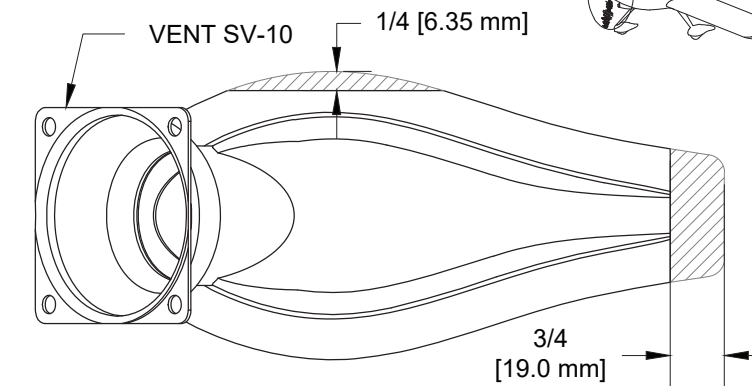

FIGURE 3: FRESH AIR VENT TRIM
(VENT SV-10-L FOR LEFT SIDE SHOWN)

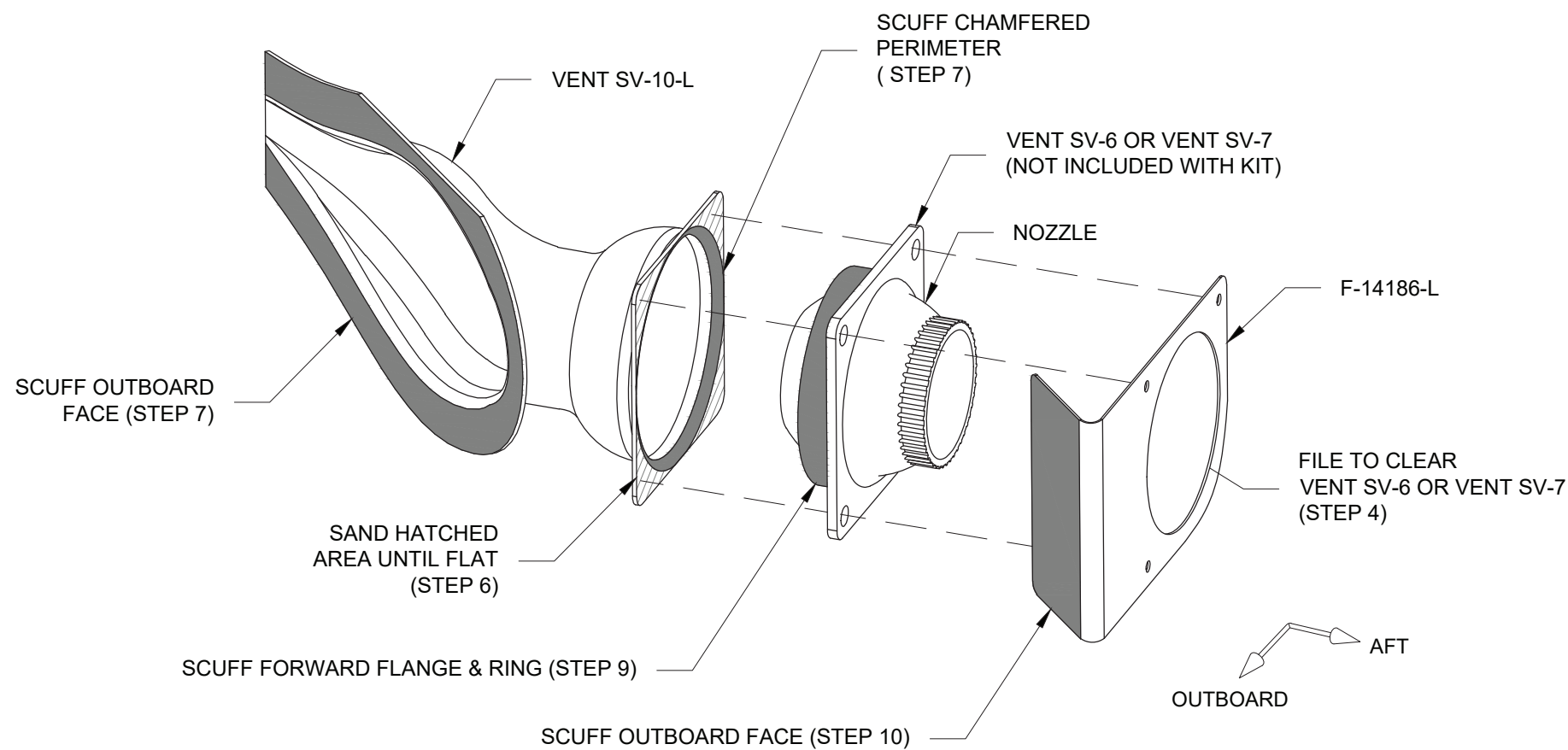

FIGURE 4: LEFT AIR VENT ASSEMBLY

NOTE: Delay the following steps until after the completion of Section 35 to eliminate the possibility of interference with the bottom of the instrument panel.

Step 1: Position the clamped together Left Air Vent Assembly to the fuselage as shown in Figure 1 and Figure 2. Ensure the outboard surfaces of the the Vent SV-10 Fresh Air Vent and F-14186-L NACA Vent Bracket are both flush with the side skin. Re-clamp as necessary.

Step 2: Mark the location of the clamped together Left Air Vent Assembly for final installation and remove it from the fuselage, keeping the assembly clamped together.

Step 3: Match Drill 9/64 [3.6 mm] the holes in the F-14186-L NACA Vent Bracket through the holes in the VENT SV-6 or VENT SV-7 and into the SV-10-L Fresh Air Vent as shown in Figure 2.

Step 4: Mark the outline of the F-14186-L NACA Vent Bracket onto the VENT SV-6 or VENT SV-7 and VENT-SV-10 Fresh Air Vent and trim as shown in Figure 2.

NOTE: Silicone repels paint. Use caution when applying near surfaces where painting may occur.

Step 5: Assemble the Left Vent Assembly as shown in Figure 3. Seal using silicone adhesive as shown. Lightly torque the nuts to prevent cracking.

Step 6: Apply a thin bead of silicone adhesive to the outboard faces of the Vent-SV-10-L Fresh Air Vent and F-14186-L NACA Vent Bracket, and use a craft stick to smooth the silicone into the surfaces prior to bonding.

Step 7: Position and clamp the Left Vent Assembly to the F-01470-L side skin, using the location marked in Step 2.

Step 8: Allow the silicone adhesive to cure before unclamping.

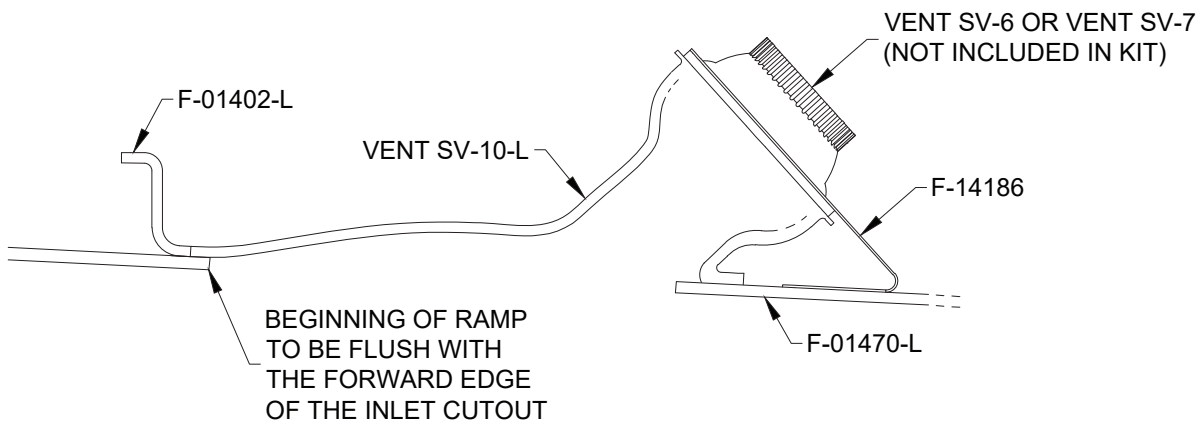

FIGURE 1: AIR VENT INSTALLATION
(SOME THICKNESSES EXAGGERATED)

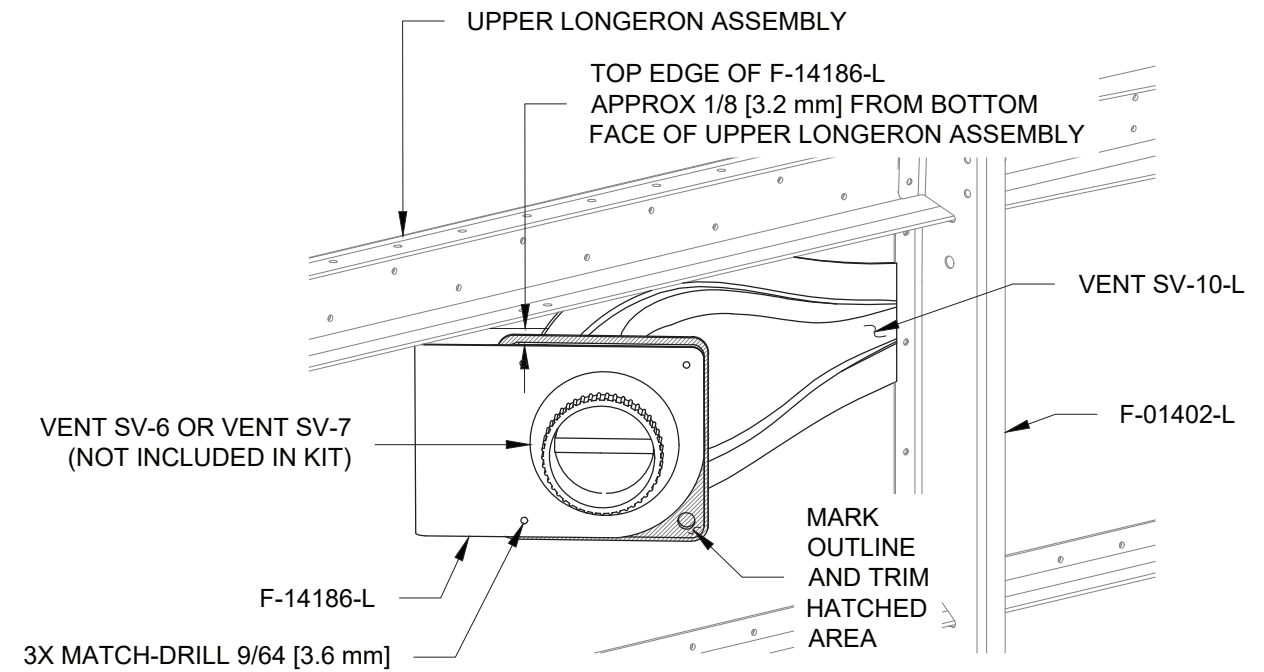

FIGURE 2: AIR VENT INSTALLATION

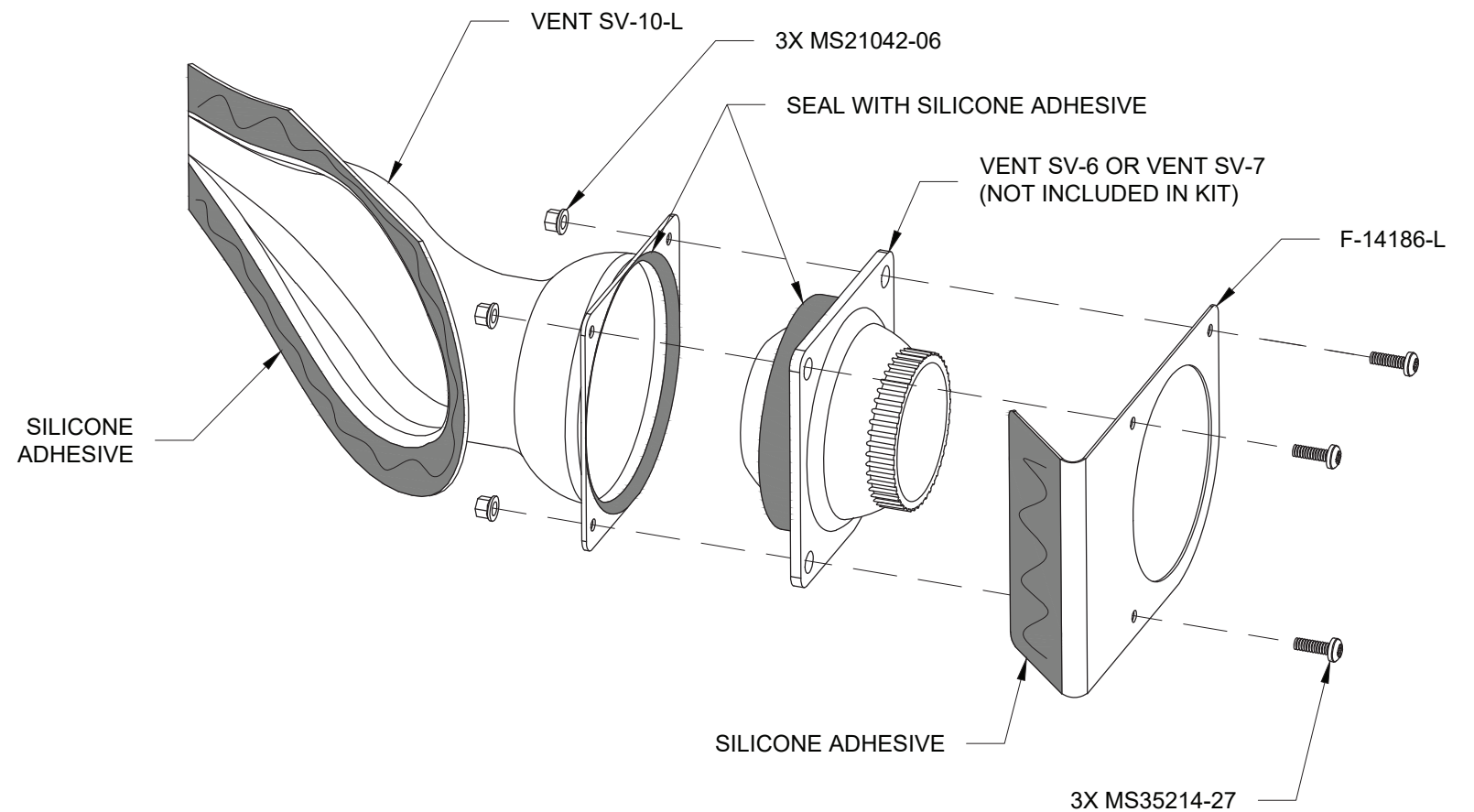

FIGURE 3: LEFT AIR VENT ASSEMBLY