

NOTE: The instructions on this page are for the retrofit of the C-01458 Guide Pin to earlier versions of the C-01427-L Aft Canopy Rail that did not include pre-punched holes for the guide pin.

NOTE: Perform the following steps on both sides of the fuselage.

Step 1: Tape the included guide pin template to the upper surface of the C-01427-L Aft Canopy Rail Flange as shown in Figure 1.

Step 2: Strike the center of the large template hole with a center punch as shown in Figure 1.

Step 3: Drill #30 the C-01427-L Aft Canopy Rail Flange where it was struck by the center punch.

Step 4: Use a step drill to enlarge the #30 hole drilled in the previous step to 5/16.

Step 5: Insert the pin of the C-01458 Guide Pin into the 5/16 hole from the top side.

Rotate the guide pin until it aligns with the template.

Securely tape the guide pin over the template.

Step 6: Match-Drill #40 the C-01458 Guide Pin holes into the C-01427-L Aft Canopy Rail Flange.

Step 7: Machine countersink the two holes on the bottom of the C-01409 -L Aft Canopy Rail Angle. See Figure 1.

Step 8: Remove the C-01458 Guide Pin and template from the C-01427-L Aft Canopy Rail Flange.

Step 9: Follow the instructions on Pages 38-37 and 38-38 to finish installation of the C-01458 Guide Pin and C-01457 Guide Plate.

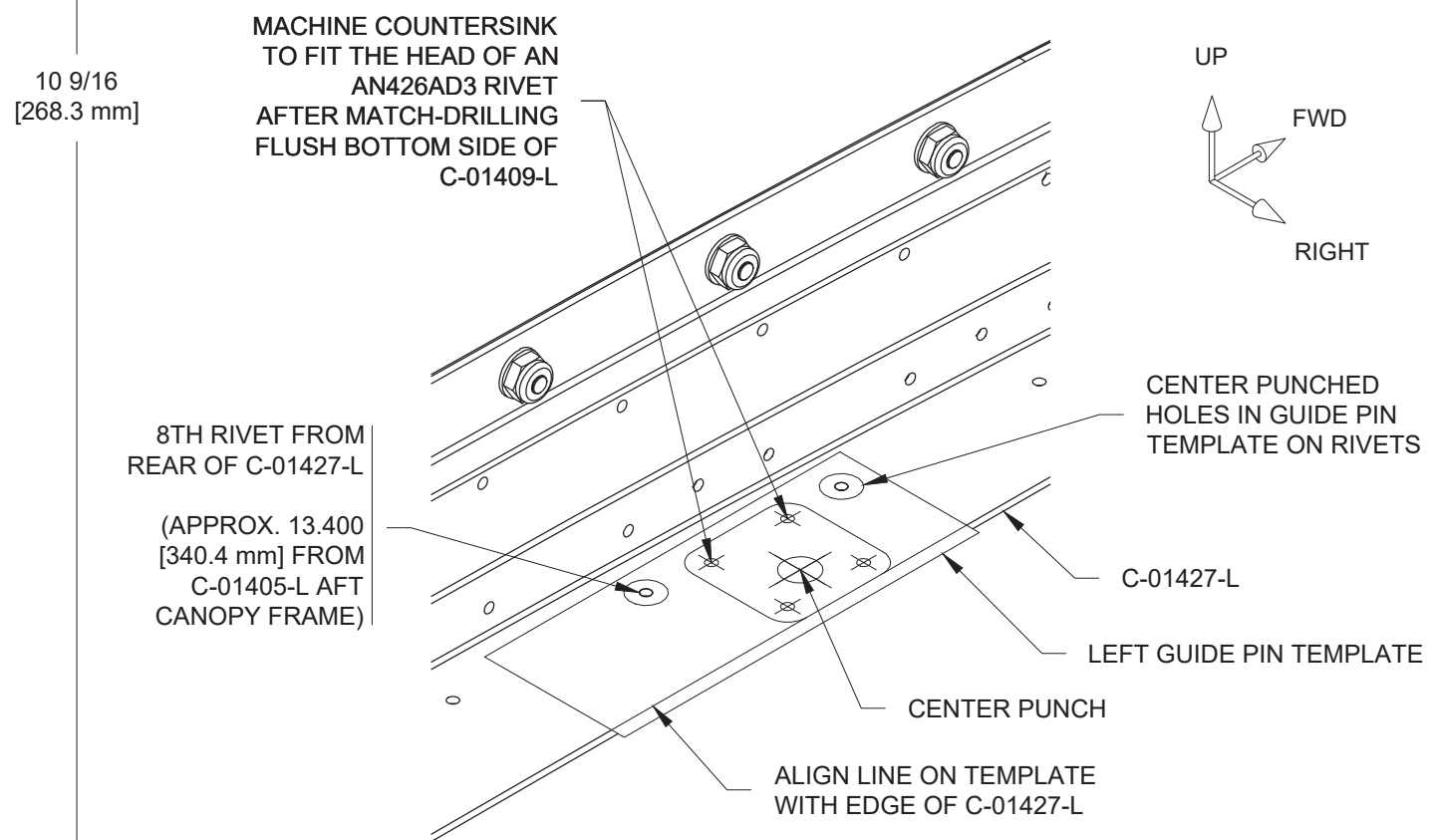
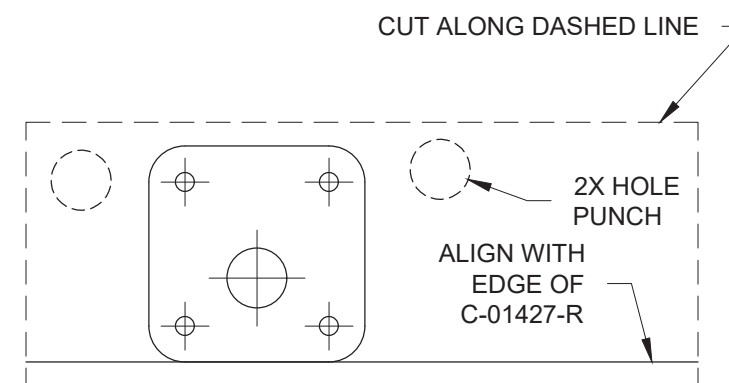
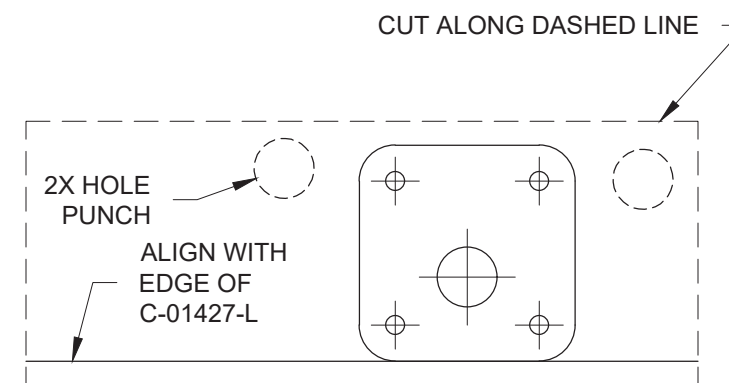

FIGURE 1: TAPE GUIDE PIN TEMPLATE

FIGURE 2: GUIDE PIN TEMPLATES
(NOTE: CHECK PRINTED SCALE 1:1 PER SECTION 3 BEFORE USING THE TEMPLATE!)