



## SERVICE BULLETIN 00036 - REV 3

<b>Date Released:</b>	February 28, 2023 (Revision 3 – Corrections made) February 25, 2023 (Revision 2 – New parts and method of compliance) February 2, 2023 (Revision 1) January 23, 2023 (Initial release)
<b>Date Effective:</b>	January 23, 2023
<b>Subject:</b>	Cracking in horizontal stabilizer rear spar at outboard elevator hinge brackets
<b>Affected Models:</b>	RV-3, RV-4, RV-6/6A, RV-9/9A, RV-10, RV-14/14A  RV-7/7A and RV-8/8A Empennage Kits shipped prior to November 2022
<b>Required Action:</b>	Inspect the rear spar web at the outboard elevator hinge bracket for cracks. If cracks are present in the spar web, replace the spar or stop drill the cracks, install doublers, and replace the elevator hinge brackets with updated parts.
<b>Time of Compliance:</b>	Inspect within 25 flight hours or at the next annual inspection, whichever is earlier.  If cracks are <u>not</u> present, you may continue to comply with this Service Bulletin via the prescribed inspection no less than every 12 months, or you may complete the modifications described in this service bulletin for aircraft without cracks.  If cracks <u>are</u> present, the modifications required by this Service Bulletin must be completed before further flight.
<b>Supersedes Notice:</b>	N/A
<b>Labor Required / SLSA Warranty Allowance:</b>	N/A
<b>Level of Certification:</b>	Check the rules of the local controlling agency and the operating limitations for your aircraft

**NOTE: Van's Aircraft shipped elevator hinge brackets to a number of customers as part of SB-00036-KIT in conjunction with the initial release of this Service Bulletin. These parts were also included in RV-4, RV-7 and RV-8 empennage kits shipped between approximately November 2022 and January 2023. The parts numbers affected are HS-00715C, HS-00715D, HS-00715E, and HS-00715F. These parts should be discarded and are not to be installed. If you received these parts and have already installed them, replace them with the revised parts described in this document.**

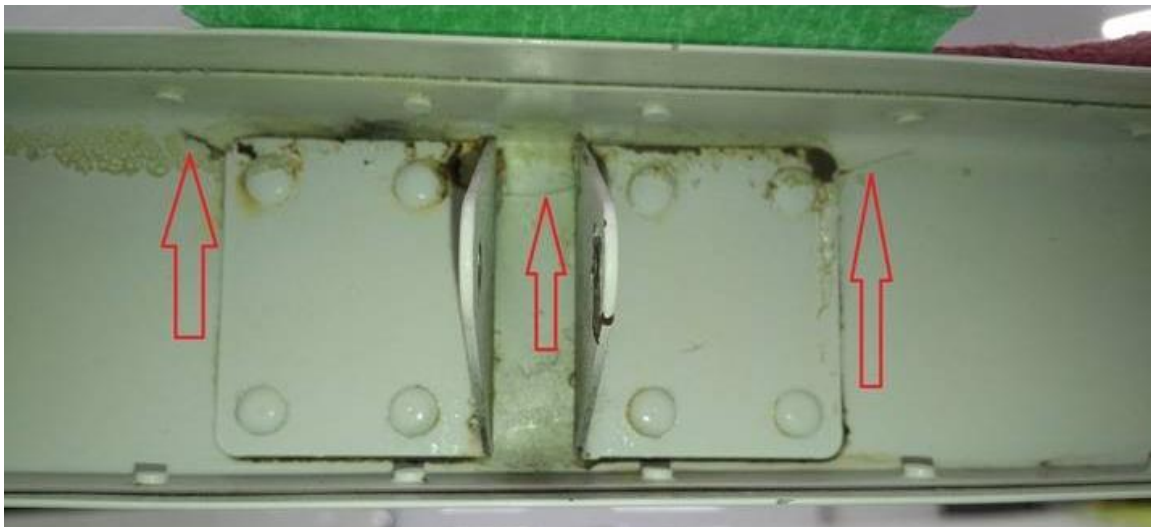
**Synopsis:**

Van's Aircraft has received reports of cracks forming in the outboard elevator hinge bracket areas of the horizontal stabilizer rear spar. See Figures 1 through 4 below for visual examples of cracks.

Formation of these cracks is caused by loads from the elevator hinge pushing and pulling on the web of the rear spar. This has been observed and reported on multiple RV-3, RV-4, RV-6, RV-7 and RV-8 aircraft, in many cases where aerobatics were performed and the airframe total times were near 2,000 hours, although cracks have since been reported on aircraft with a variety of total times and operations.

Potential causes include but are not limited to:

- stiffness of the original design
- misalignment of the elevator hinge brackets
- poor hole deburring
- airframe vibrations interacting with the elevator
- failure to dynamically balance the propeller



**FIGURE 1: EXAMPLE 1 - CRACK LOCATIONS – AFT SIDE OF SPAR**



**FIGURE 2:** EXAMPLE 1 - CRACK LOCATIONS - FWD SIDE OF SPAR



**FIGURE 3:** EXAMPLE 2 - CRACK LOCATIONS - FWD SIDE OF SPAR



**FIGURE 4:** EXAMPLE 2 - CRACK LOCATIONS - FWD SIDE OF SPAR

## Materials Required:

The following materials are required to complete the steps necessary to achieve compliance with this Service Bulletin, if cracks are found in RV-3, RV-4, RV-6, RV-7, or RV-8 airframe:

**RV-3:** Order SB-00036-KIT3

**RV-4:** Order SB-00036-KIT4

**RV-6:** Order SB-00036-KIT6-NONPP

**RV-6 (with pre-punched tail), RV-7, RV-8:** Order SB-00036-KITPP

## Method of Compliance:

**NOTE: Cracks may be present, but not visible from the aft side of the spar. It is imperative that the forward side of the spar is inspected.**

**NOTE: The horizontal stabilizer rear spar on the RV-9/10/14 aircraft is designed differently than the other models covered by this Service Bulletin. Parts for the RV-9/10/14 are being evaluated and this service bulletin will be revised when new parts are released. If cracks are observed on RV-9/10/14 aircraft, please contact Van's Technical Support and supply photos of crack(s), airframe hours and aircraft type.**

**NOTE: If no cracks are observed, you may either proceed to Step 55 to complete the service bulletin via ongoing inspections, or you may retrofit the rear spar with replacement hinge brackets and spar doubler(s), as described below.**

**NOTE: When installing the Cherrymax pulled rivets included this service bulletin, please refer to [KAI Section 5](#) (Page 05-06) and the Van's Aircraft [video about preparing the rivets](#) for installation.**

Step 1: Inspect the outboard elevator hinge bracket area on the forward surface of the horizontal stabilizer rear spar for cracks. Examples of cracks are shown in Figures 1 through 4.

For RV-3/4/6/7/8 aircraft, the aft tooling hole in the horizontal stabilizer outboard rib can be enlarged to 7/16 to accommodate a borescope for inspection of the forward side of the rear spar. If no tooling hole is present, a hole no larger than 7/16 can be added to the outboard stabilizer rib located on the centerline of the rib 1.00 forward of the aft face of the spar. Refer to Figure 15.

For RV-9/10/14 aircraft, inspection is accomplished through the lightening holes in the rear spar and outboard stabilizer rib.

**NOTE: If cracks are found, it is important to determine the severity of the cracks. Refer to Kit Assembly Instructions (KAI) Section 5, available at <https://www.vansaircraft.com/service-information-and-revisions/5/> for rivet removal techniques and practice as needed before removing the hinge brackets.**

Step 2: Remove the outboard elevator hinge brackets to allow full inspection of the

cracks. For RV-3, RV-4, and RV-6, take care to not damage these brackets as they will be used as a template in later steps for locating holes in the new hinge brackets.

**NOTE: Typically, a crack in aluminum aircraft structure extends beyond the point where it is visible with the naked eye. Stop-drilling at the apparent visible endpoint could miss the end of the crack, allowing it to continue to propagate. Therefore, when stop-drilling a crack, the center point of the stop-drill hole should be positioned slightly beyond the apparent visual end of the crack. This way, if the crack continues to propagate, it will do so toward the hole and then stop.**

**NOTE: If spar replacement is required, refer to the applicable section of the kit plans, applicable technical drawings, and KAI. Once the new spar has been prepared, continue with the following steps to install the updated parts.**

**NOTE: Horizontal Stabilizer Rear Spar Part Numbers**

- **RV-3 - HS-303**
- **RV-4 - HS-403**
- **RV-6 Non Pre-Punched - HS-603**
- **RV-6PP/7/8 - HS-603PP**

Step 3: Evaluate the cracks in the rear spar.

Cracks meeting the following conditions mandate replacement of the spar:

- Cracks that have propagated into the bend of the spar
- Cracks that span from one rivet hole to another rivet hole

Cracks that do not meet the spar replacement criteria must be stop-drilled using a #40 hole at the extreme end of the crack. This hole must be at least .098 from the edge of any rivet hole and may not extend into the bend of the spar. If you cannot meet these minimum distance requirements when drilling, replace the rear spar.

**Use the following table to determine the applicable next Step for your aircraft model**

<b>IMPORTANT: Skip ahead to the applicable Step for your RV model:</b>	
RV-3	Start at Step 4, below
RV-4	Skip to Step 18
RV-6 (non pre-punched only)	Skip to Step 30
RV-6 (pre-punched), RV-7 and RV-8	Skip to Step 40

**NOTE: Steps 4-17 are applicable only to RV-3**

**NOTE: Any cracks in the rear spar require the installation of a repair doubler on the forward side of the rear spar. Additionally, any tails built from non pre-punched parts require access to the forward side of the rear spar in order to match drill the hinge bracket holes. To facilitate both of these situations, a sufficient number of rivets attaching the horizontal stabilizer skin to the spar and ribs must be removed to allow access.**

Step 4 (RV-3): Drill out the rivets common to the horizontal stabilizer skin and rear spar as well as the horizontal stabilizer skin and ribs to allow access to the forward side of the rear spar and the installation of the repair doubler on the forward side of the rear spar.

**NOTE: The HS-00316 Nested Spar Doubler Blank provides material to fabricate the nested spar doubler for the RV-3. The blank is tapered to match the rear spar and is longer than the required nested spar doubler. This allows the desired part to be cut/trimmed from a section of the blank to fit in the rear spar at the location of the outboard elevator hinge brackets. This part was designed using a CNC bent spar at Van's, and as such it may not fit builder-produced parts on RV-3 aircraft. If it does not fit, you will need to fabricate a doubler as described starting in Step 5 below.**

Step 5 (RV-3): Fabricate a bent doubler from HS-00316 Nested Spar Doubler Blank or from .040 2024-T3 that will nest into the rear spar at the outboard hinge brackets. The doubler should be centered on the hinge brackets location.

See Figure 10 for an example flat pattern. This example shows holes that will be in the doubler when it is ready for installation.

See Figure 11 for bending guidelines.

See Figure 12 for trimming guidelines. Trim after bending. The minimum length of the doubler is 7.00. The doubler must also capture at least three rivets on each side of outboard hinge brackets.

**NOTE: Original RV-3 and some RV-4 hinge brackets only had two holes common to the rear spar and were fabricated from aluminum angle. The new hinge brackets have four holes in each bracket common to the rear spar and are to be fabricated from 4130 Condition N Steel. The original hinge bracket holes are to be match drilled into the new hinge brackets while the two additional holes in each hinge bracket will need to be located as stated below.**

Step 6 (RV-3): Fabricate outboard elevator hinge brackets from .063 4130 Condition N Steel. See Figures 13 and 14 for guidelines.

Step 7 (RV-3 – If cracks are present): Fabricate a repair doubler from .063 2024-T3 (or trim a HS-00718B Repair Doubler) to fit the forward side of the rear spar captures all holes from the hinge brackets. See Figure 9 for an example.

Step 8 (RV-3): Clamp the nested spar doubler into the appropriate location in the spar. See Figure 5 for an example installation.

Step 9 (RV-3): Match drill the holes common to the skin and rear spar into the nested spar doubler. The doubler should capture at least six rivets from the skin and rear spar in each flange of the doubler. The doubler must be at least 7.00 in length. See Figure 5 for an example installation and Figure 12 for final trimming guidelines.

Step 10 (RV-3): Remove the nested spar doubler from the rear spar.

Step 11 (RV-3 – If cracks are present): Clamp the HS-00718B Repair Doubler on the forward side of the rear spar centered on the rivet hole pattern for the hinge brackets.

Step 12 (RV-3 – If cracks are present): Match drill the repair doubler to the rear spar.

Step 13 (RV-3): Drill the holes common to the hinge brackets and the rear spar in the new outboard elevator hinge brackets using the original hinge brackets that were removed from the rear spar as a template. Reference Figure 13.

Step 14 (RV-3): Match drill the two new holes in the hinge brackets to the nested spar doubler, rear spar, and repair doubler (if required). Reference Figure 13.

**NOTE: Use the original Outboard Elevator Hinge Brackets that were removed from the spar as a template for locating the AN3 bolt pivot hole.**

Step 15 (RV-3): Place a new hinge bracket and a .040 thick spacer, that is fabricated to fit the same footprint as the hinge bracket, onto a flat surface. See Figure 7.

Step 16 (RV-3): Clamp the triangular flange of the new hinge bracket and sheet assembly to a corresponding original hinge bracket. See Figure 7.

Step 17 (RV-3): Match drill the hole for the AN3 pivot bolt that goes through the elevator rod end. See Figure 7.

----- **PROCEED TO STEP 44** -----



**NOTE: Steps 18-29 are applicable only to RV-4**

**NOTE: Any cracks in the rear spar require the installation of a repair doubler on the forward side of the rear spar. Additionally, any tails built from non pre-punched parts require access to the forward side of the rear spar in order to match drill the hinge bracket holes. To facilitate both of these situations, a sufficient number of rivets attaching the horizontal stabilizer skin to the spar and ribs must be removed to allow access.**

Step 18 (RV-4): Drill out the rivets common to the horizontal stabilizer skin and rear spar as well as the horizontal stabilizer skin and ribs to allow access to the forward side of the rear spar and the installation of the repair doubler on the forward side of the rear spar.

Step 19 (RV-4 – If cracks are present): Fabricate a repair doubler from .063 2024-T3 or trim a HS-00718B Repair Doubler to fit the forward side of the rear spar. See Figure 9 for an example.

**NOTE: The HS-00416 Nested Spar Doubler Blank provides material to fabricate a nested spar doubler for the RV-4. The blank is tapered to match the rear spar and is longer than the required nested spar doubler. This allows the doubler to be cut from a section of the blank material to provide a proper fit in the rear spar for the location of the outboard elevator hinge brackets.**

Step 20 (RV-4): Slide the HS-00416 Nested Spar Doubler Blank into the spar to produce a tight fit and provide enough material to meet the guidelines in Figure 10 and Figure 12. See Figure 5 for an example final installation.

Step 21 (RV-4): Match drill the holes common to the skin and rear spar into the nested spar doubler. The doubler should capture at least six rivets from the skin and rear spar in each flange of the doubler. See Figure 5 for an example installation.

Step 22 (RV-4): Trim the nested spar doubler. The holes in the flanges of the nested spar doubler will drive the total length of the doubler, but it must be 7.00 in length at a minimum. See Figure 12 for trimming guidelines.

Step 23 (RV-4): Remove the nested spar doubler from the rear spar.

Step 24 (RV-4 – If cracks are present): Clamp the HS-00718B Repair Doubler on forward side of the rear spar. Center the doubler on the rivet hole pattern for the hinge brackets.

Step 25 (RV-4 – If cracks are present): Match drill the repair doubler using the rear spar.

**NOTE: Original RV-3 and some RV-4 hinge brackets only had two holes common to the rear spar and were fabricated from aluminum angle. The new hinge brackets have four holes in each bracket common to the rear spar and are to be fabricated from 4130 Condition N Steel. The original hinge bracket holes are to be match drilled into the new hinge brackets while the two additional holes in each hinge bracket will need to be located as stated below.**



**NOTE: HS-00717B Outboard Elevator Hinge Brackets that are powder coated have a .063 hole from the factory. This hole is used in the manufacturing process and is not to be riveted.**

Step 26 (RV-4): Drill the holes common to the hinge brackets and the rear spar in the new HS-00717B Outboard Elevator Hinge Brackets using the original hinge brackets that were removed from the rear spar as a template.

**NOTE: Use the original Outboard Elevator Hinge Brackets that were removed from the spar as a template for locating the AN3 bolt pivot hole.**

Step 27 (RV-4): Place a HS-00717B hinge bracket and a .040 thick spacer, that is fabricated to fit the same footprint as the hinge bracket, onto a flat surface. See Figure 7.

Step 28 (RV-4): Clamp the triangular flange of the HS-00717B hinge bracket and sheet assembly to a corresponding original hinge bracket. See Figure 7.

Step 29 (RV-4): Match drill the hole for the AN3 pivot bolt that goes through the elevator rod end. See Figure 7.

----- **PROCEED TO STEP 44** -----

**NOTE: Steps 30-39 are applicable only to non pre-punched RV-6. If the horizontal stabilizer skins, rear spar, and outboard elevator hinge brackets on your aircraft are pre-punched parts, SB-00036-KITPP should be used instead, along with the RV-7/8 instructions, starting at Step 39, later in this document.**

**NOTE: RV-6 aircraft that do not have a pre-punched empennage require the use of a HS-00716B Nested Spar Doubler. It nests into the existing rear spar, but contains no holes, which allows the holes to be match drilled using the existing rear spar holes.**

**NOTE: Any cracks in the rear spar require the installation of a Repair Doubler on the forward side of the rear spar. Additionally, any tails built from non pre-punched parts require access to the forward side of the rear spar in order to match drill the hinge bracket holes. To facilitate both of these situations, a sufficient number of rivets attaching the horizontal stabilizer skin to the spar and ribs must be removed to allow access.**

Step 30 (RV-6): Drill out the rivets common to the horizontal stabilizer skin and rear spar as well as the horizontal stabilizer skin and ribs to allow access to the forward side of the rear spar and the installation of the repair doubler on the forward side of the rear spar.

Step 31 (RV-6): Clamp the HS-00716B Nested Spar Doubler into the appropriate location centered on the hinge bracket hole pattern. See Figure 5 for an example installation.

Step 32 (RV-6): Match drill the holes common to the skin and rear spar into the nested spar doubler. The doubler should capture at least six rivets from the skin and rear spar in each flange of the doubler. See Figure 5 for an example installation.

Step 33 (RV-6): Remove the nested spar doubler from the rear spar.

Step 34 (RV-6 – If cracks are present): Clamp the HS-00718B Repair Doubler on forward side of the rear spar. Center the doubler on the rivet hole pattern for the hinge brackets.

Step 35 (RV-6 – If cracks are present): Match drill the repair doubler using the rear spar.

**NOTE: HS-00717B Outboard Elevator Hinge Brackets that are powder coated have a .063 hole from the factory. This hole is used in the manufacturing process and is not to be riveted.**

Step 36 (RV-6): Drill the holes common to the hinge brackets and the rear spar in the new HS-00717B Outboard Elevator Hinge Brackets using the original hinge brackets that were removed from the rear spar as a template.

**NOTE: Use the Outboard Elevator Hinge Brackets that were removed from the spar as a template for locating the AN3 bolt pivot hole.**

Step 37 (RV-6): Place a HS-00717B hinge bracket and a .040 thick spacer, that is fabricated to fit the same footprint as the hinge bracket, onto a flat surface. See Figure 7.

Step 38 (RV-6): Clamp the triangular flange of the HS-00717B hinge bracket and sheet assembly to a corresponding original hinge bracket. See Figure 7.

Step 39 (RV-6): Match drill the hole for the AN3 pivot bolt that goes through the elevator rod end. See Figure 7.

----- **PROCEED TO STEP 44** -----

**NOTE: Steps 40-43 apply to RV-6 with pre-punched empennage, all RV-7, and all RV-8 aircraft.**

**NOTE: Any cracks in the rear spar require the installation of a repair doubler on the forward side of the rear spar. To facilitate the installation, a sufficient number of rivets attaching the horizontal stabilizer skin to the spar and ribs must be removed to allow access.**

Step 40 (RV-6PP/7/8 - If cracks are present): Drill out the rivets common to the horizontal stabilizer skin and rear spar as well as the horizontal stabilizer skin and ribs to allow access to the forward side of the rear spar for installation of the repair doubler.

**NOTE: See Figure 6 for a section view of the assembly.**

Step 41 (RV-6PP/7/8): Cleco the HS-00716A Nested Spar Doubler to the rear spar and match drill the holes common to the skin, rear spar, hinge brackets.

Step 42 (RV-6PP/7/8 – If cracks are present): Cleco the HS-00718A Repair Doubler to the forward side of the rear spar and match drill the holes common to the rear spar, nested spar doubler, and hinge brackets.

Step 43 (RV-6PP/7/8): Cleco the HS-00717A Outboard Elevator Hinge Brackets to the rear spar and match drill the holes common to the rear spar, nested spar doubler, and repair doubler (if required). See Figure 5.

----- **PROCEED TO STEP 44** -----

**NOTE: The remaining steps apply to all RV models.**

Step 44: Deburr holes in all parts.

Step 45: Dimple the holes in the flanges of the nested spar doubler.

Step 46: Prime the steel outboard elevator hinge brackets if they are not already coated.

Step 47: Prime all aluminum parts if desired.

Step 48: Cleco the nested spar doubler to the rear spar and skin.

Step 49: Cleco the hinge brackets to the rear spar and nested spar doubler. See Figure 5 and Figure 6 for reference.

Step 50 (If cracks are present): Cleco the repair doubler to the forward side of the rear spar. See Figure 6 for reference.

Step 51: Rivet the holes common to the hinge brackets, nested spar doubler, rear spar, and repair doubler (if required). See Figures 5 and 6.

Step 52: Rivet the holes common to the skins, rear spar, and nested spar doubler. See Figure 5 for rivet callouts.

Step 53: Match drill the .189 hole in the hinge brackets to .191.

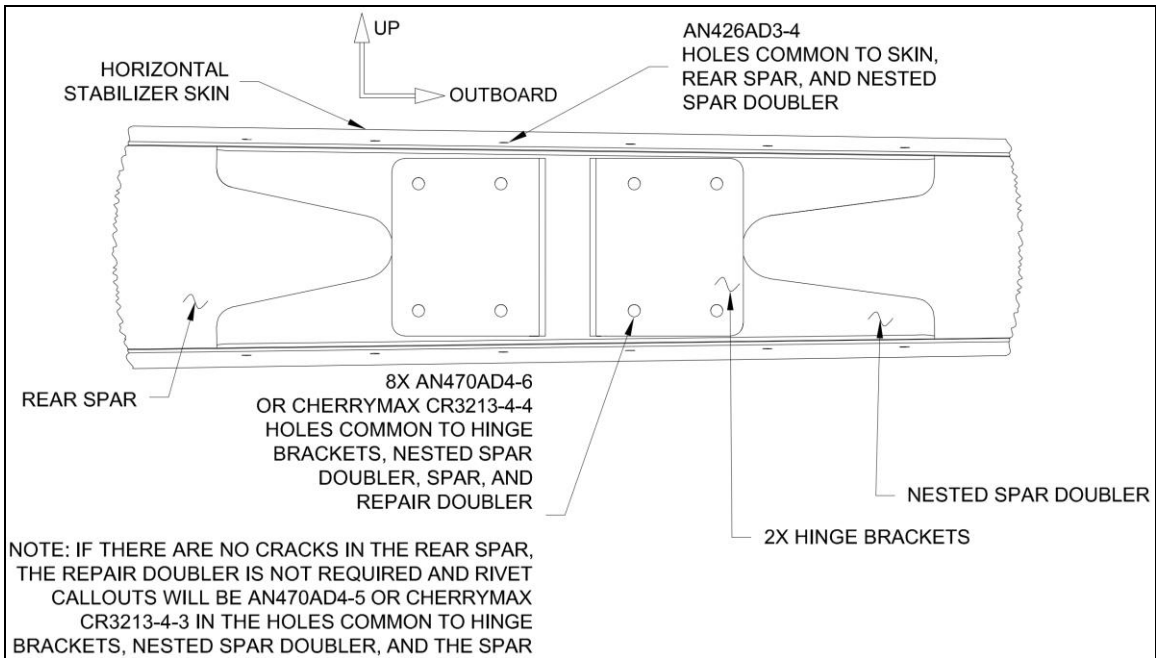
**NOTE: If the skin was not separated from the spar for doubler installation, the tooling hole that was enlarged for the borescope in Step 1 can be used to insert a vacuum tube into the horizontal stabilizer.**

Step 54: Vacuum interior of horizontal stabilizer to clean up any debris from the rivet removal process.

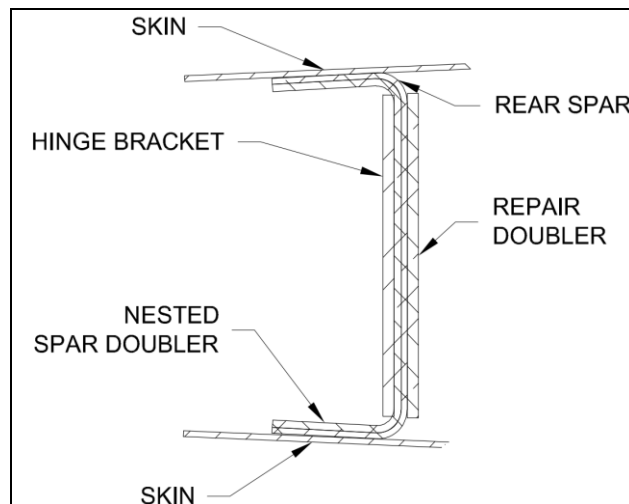
Step 55: Make a logbook entry indicating compliance with service document, method of compliance (inspection or parts replacement), and what parts were installed (if any) per the requirements of the controlling authority/agency.

If you are no longer in possession of this aircraft, please forward this information to the present owner/operator and immediately notify Van's Aircraft, Inc. via email at [registrations@vansaircraft.com](mailto:registrations@vansaircraft.com).

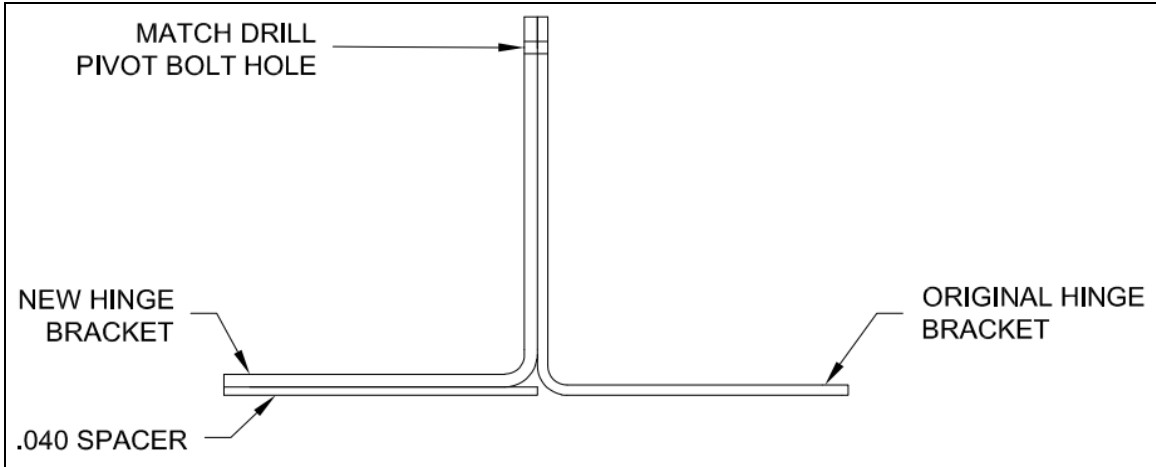
Information regarding establishing/transferring aircraft ownership, registration and licensing is available at: <https://www.vansaircraft.com/gr/transfer-of-ownership/>



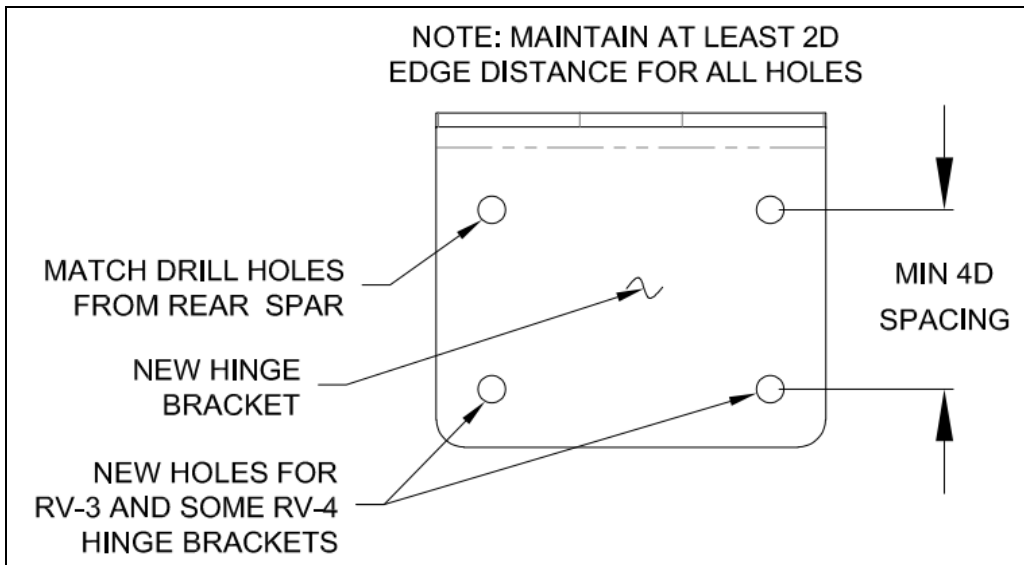
**FIGURE 5:** RIVET CALLOUTS AND REAR SPAR AFT VIEW



**FIGURE 6:** REAR SPAR SECTION VIEW

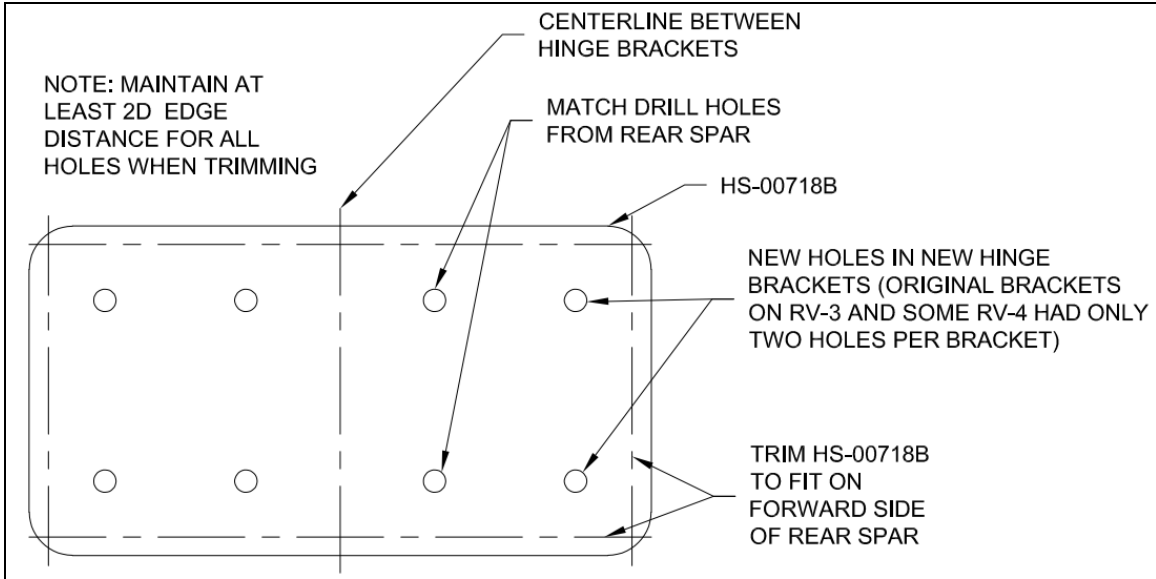


**FIGURE 7:** MATCH DRILLING PIVOT BOLT HOLE

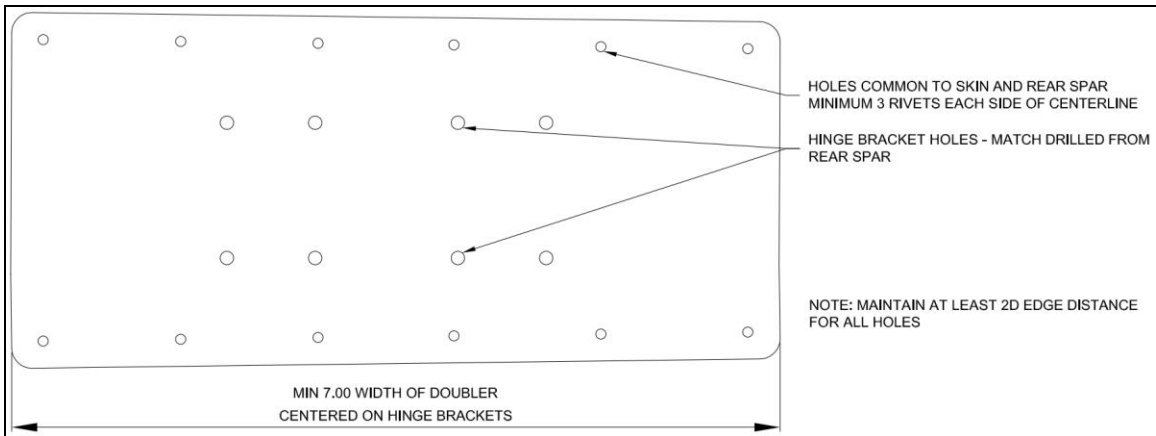


**FIGURE 8:** HINGE BRACKET RIVET LOCATIONS FOR NON PRE-PUNCHED KITS

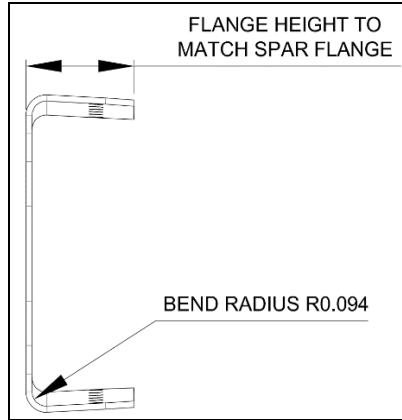




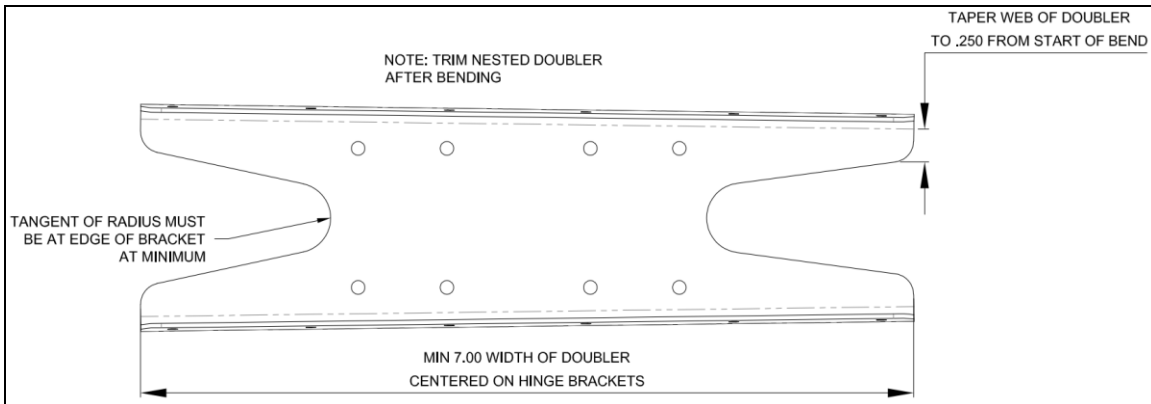
**FIGURE 9:** EXAMPLE HS-00718B REPAIR DOUBLER



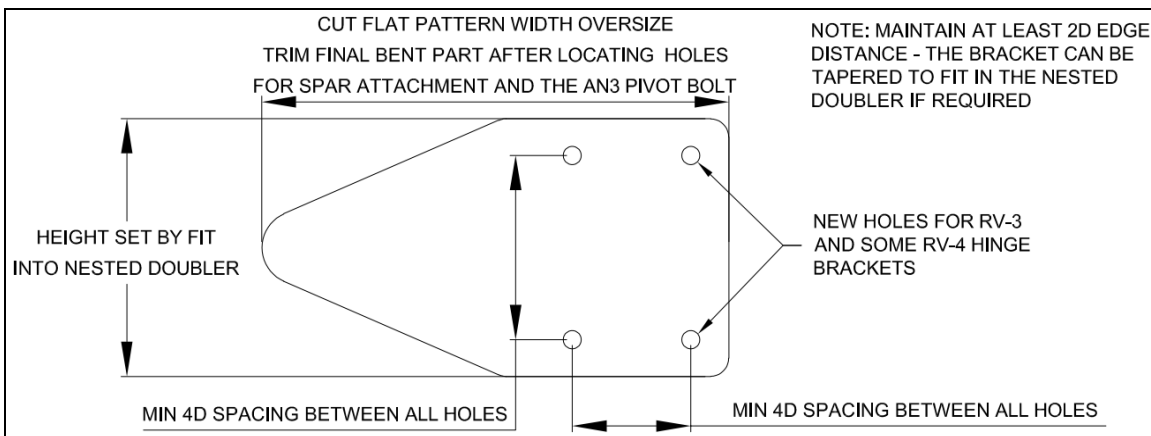
**FIGURE 10:** EXAMPLE NESTED SPAR DOUBLER FLAT PATTERN



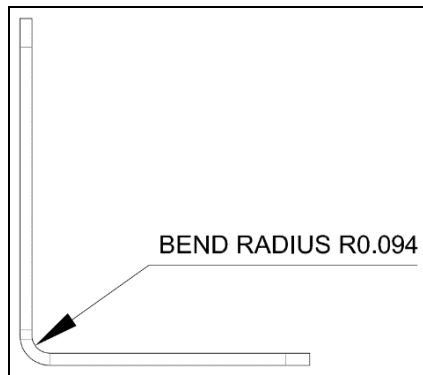
**FIGURE 11:** BEND PROFILE – NESTED SPAR DOUBLER



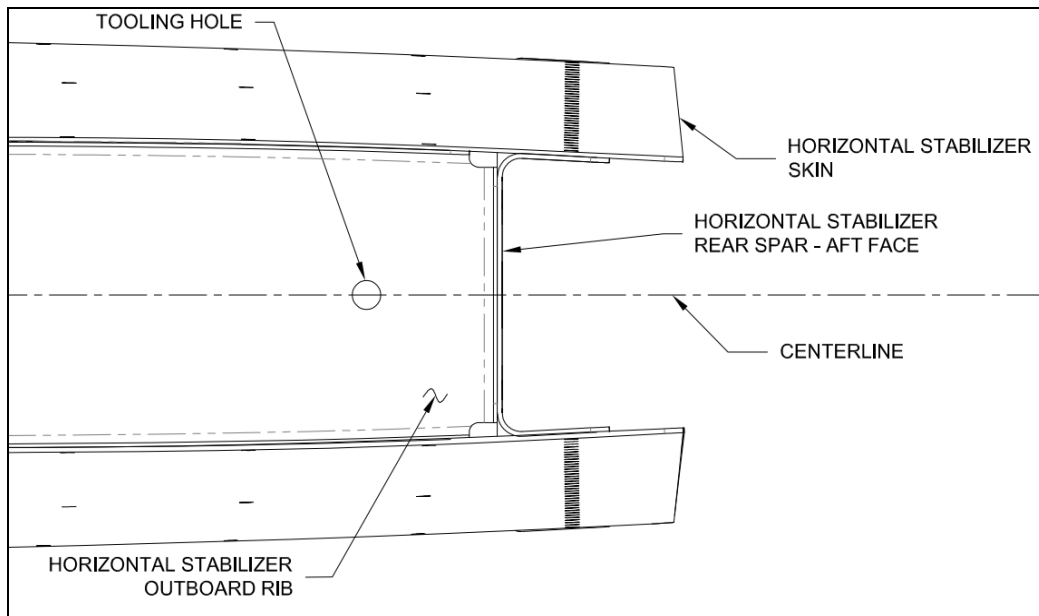
**FIGURE 12:** NESTED SPAR DOUBLER TRIM GUIDELINES



**FIGURE 13:** HINGE BRACKET FLAT PATTERN GUIDELINES



**FIGURE 14:** HINGE BRACKET BEND GUIDELINES



**FIGURE 15:** TOOLING HOLE

(VIEW LOOKING INBOARD FROM TIP OF HORIZONTAL STABILIZER)