

SECTION 48: EXHAUST SYSTEM

NOTE:
ENGINE INSTALLATION
SHOWN FOR REFERENCE
ONLY AS SOME DETAILS
MAY BE OMITTED OR OBSOLETE

NOT SHOWN:
EX-00044D
CYLINDER #4
EXHAUST

NOT SHOWN:
EX-00044B
RV-12 CYL
#2 EXHAUST
ASSEMBLY

EX-00044C
RV-12 CYL #3
EXHAUST
ASSEMBLY

EGT PROBE
(PART OF DYNON
ENGINE SENSOR KIT)

EX-00044A
RV-12 CYL #1
EXHAUST
ASSEMBLY

938 795
SPRING,
8 PLACES

EX-00044E MUFFLER
ASSEMBLY, RV-12

DATE OF COMPLETION: _____

PARTICIPANTS: _____

DATE: 12/12/22 | REVISION: 3 | RV-12 | PAGE 48-01

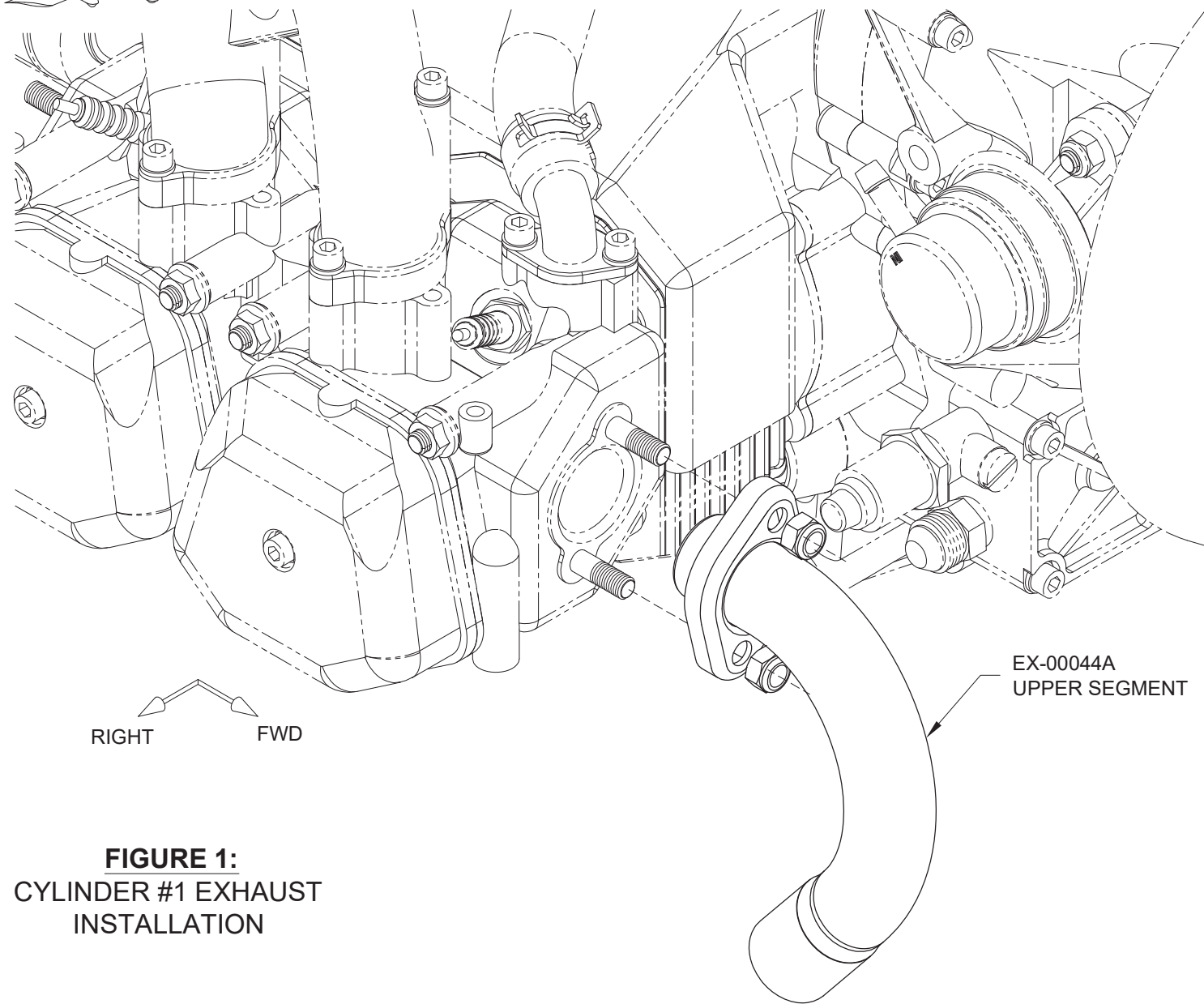
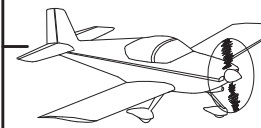

FIGURE 1:
CYLINDER #1 EXHAUST
INSTALLATION

NOTE: Details of the engine installation that do not pertain to the exhaust system are shown for reference only as some features may have been omitted or are obsolete.

Step 1: Remove the exhaust port plugs and exhaust stud nuts from all four cylinders of the engine. Discard the plugs but keep the nuts for use in this section.

Step 2: Install the upper segment of the EX-00044A RV-12 Cyl #1 Exhaust Assembly into the right side forward exhaust port as shown in Figure 1. Start the exhaust stud nuts onto the studs but do not tighten further than the point at which the exhaust stud begins to extend beyond the end of the nut.

Step 3: Install the EX-00044B RV-12 Cyl #2 Exhaust Assembly into the left side forward exhaust port as shown in Figure 2. Start the exhaust stud nuts onto the studs but do not tighten further than the point at which the exhaust stud begins to extend beyond the end of the nut.

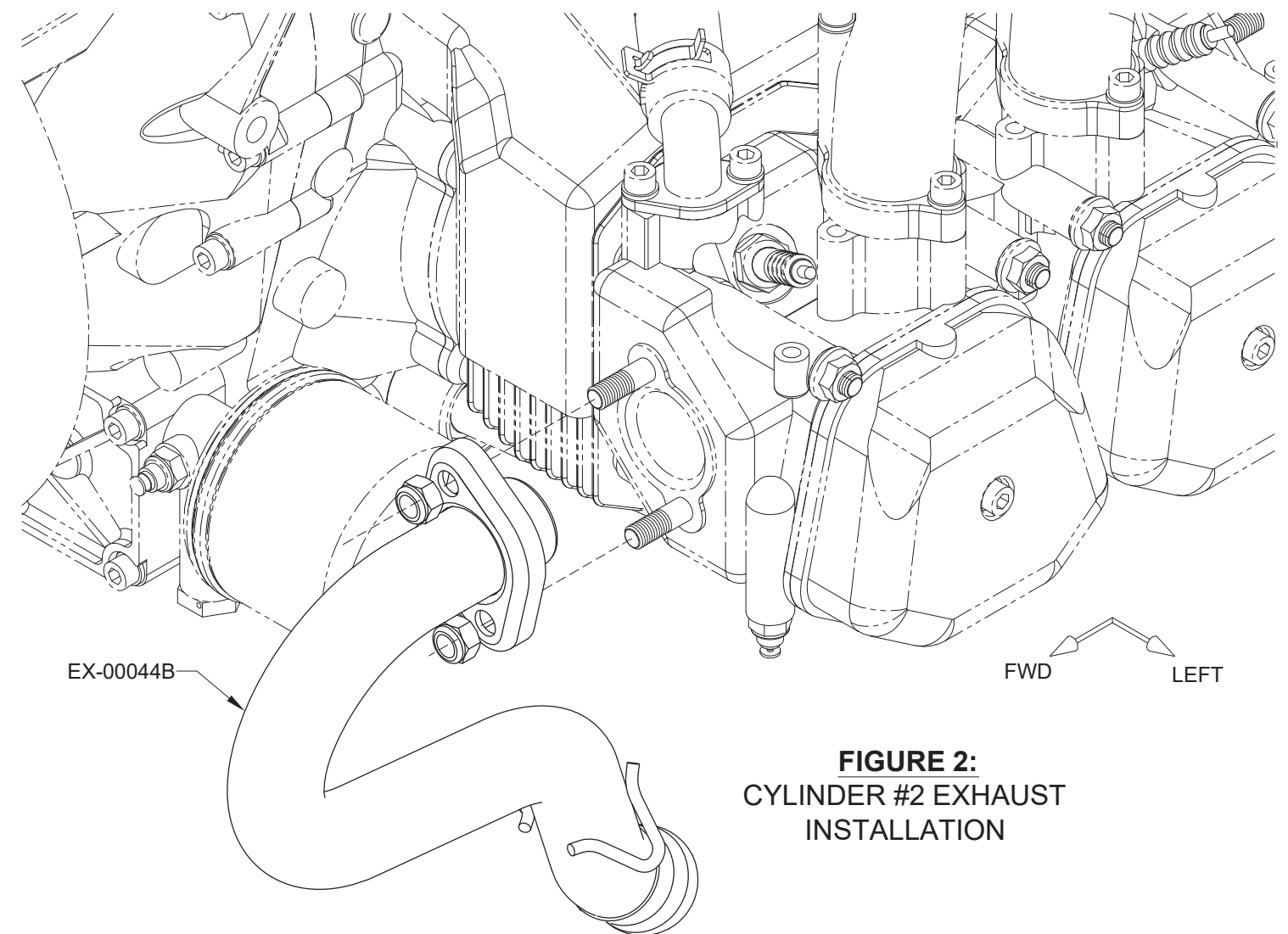
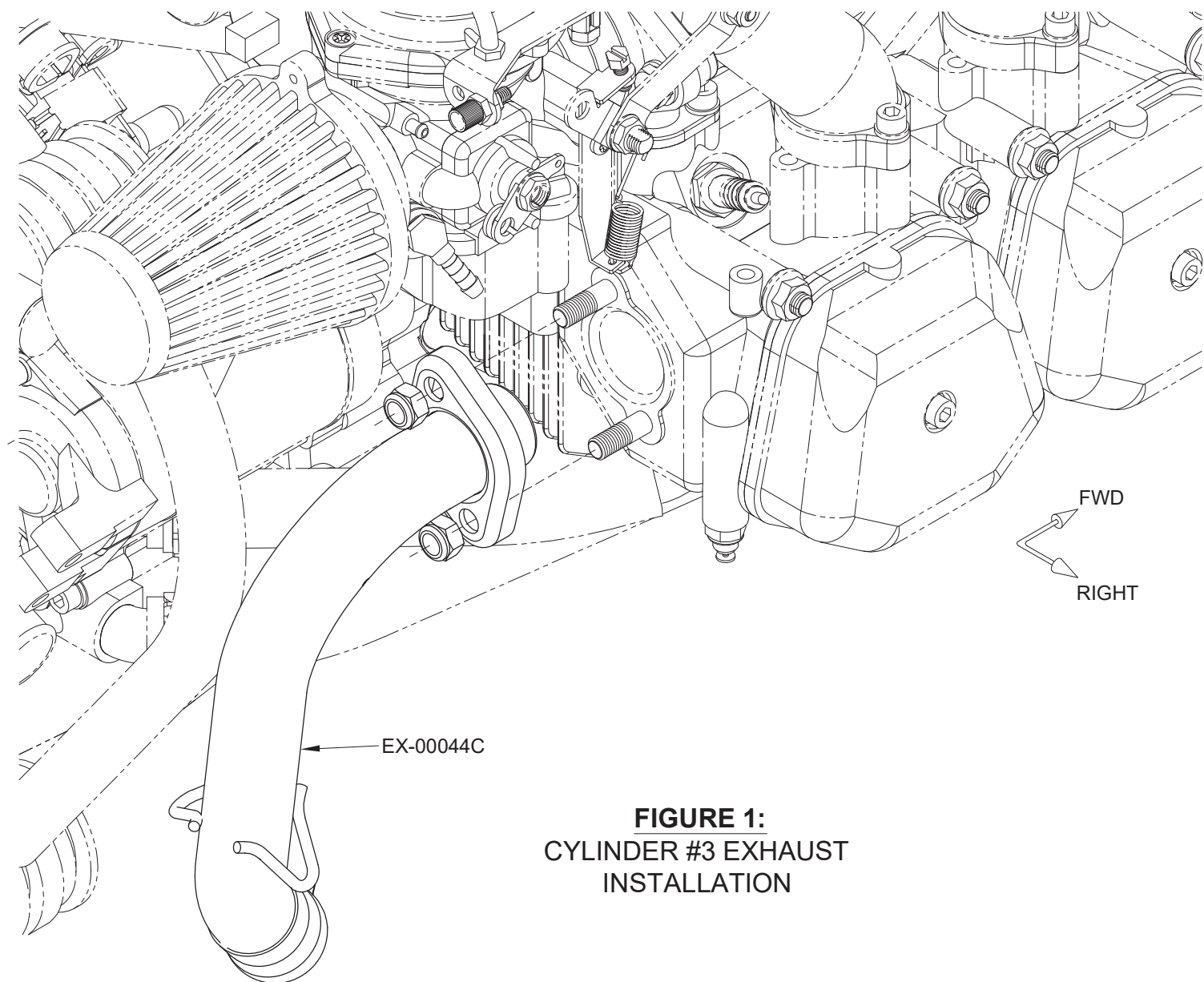

FIGURE 2:
CYLINDER #2 EXHAUST
INSTALLATION



**FIGURE 1:
CYLINDER #3 EXHAUST
INSTALLATION**

Step 1: Install the EX-00044C RV-12 Cyl #3 Exhaust Assembly into the right side aft exhaust port as shown in Figure 1. Start the exhaust stud nuts onto the studs but do not tighten further than the point at which the exhaust stud begins to extend beyond the end of the nut.

Step 2: Install the EX-00044D RV-12 Cyl #4 Exhaust Assembly into the left side aft exhaust port as shown in Figure 2. Start the exhaust stud nuts onto the studs but do not tighten further than the point at which the exhaust stud begins to extend beyond the end of the nut.

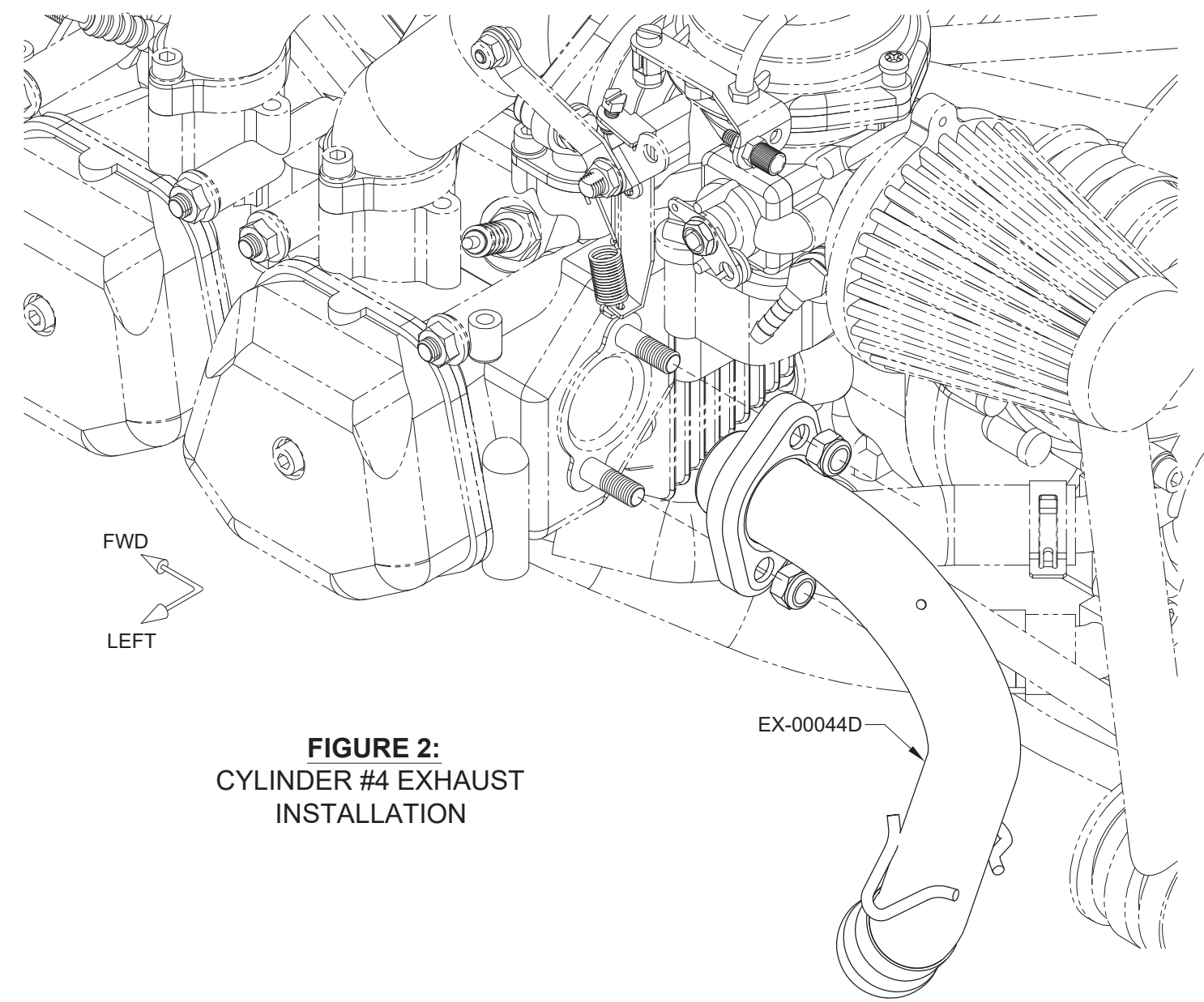

**FIGURE 2:
CYLINDER #4 EXHAUST
INSTALLATION**

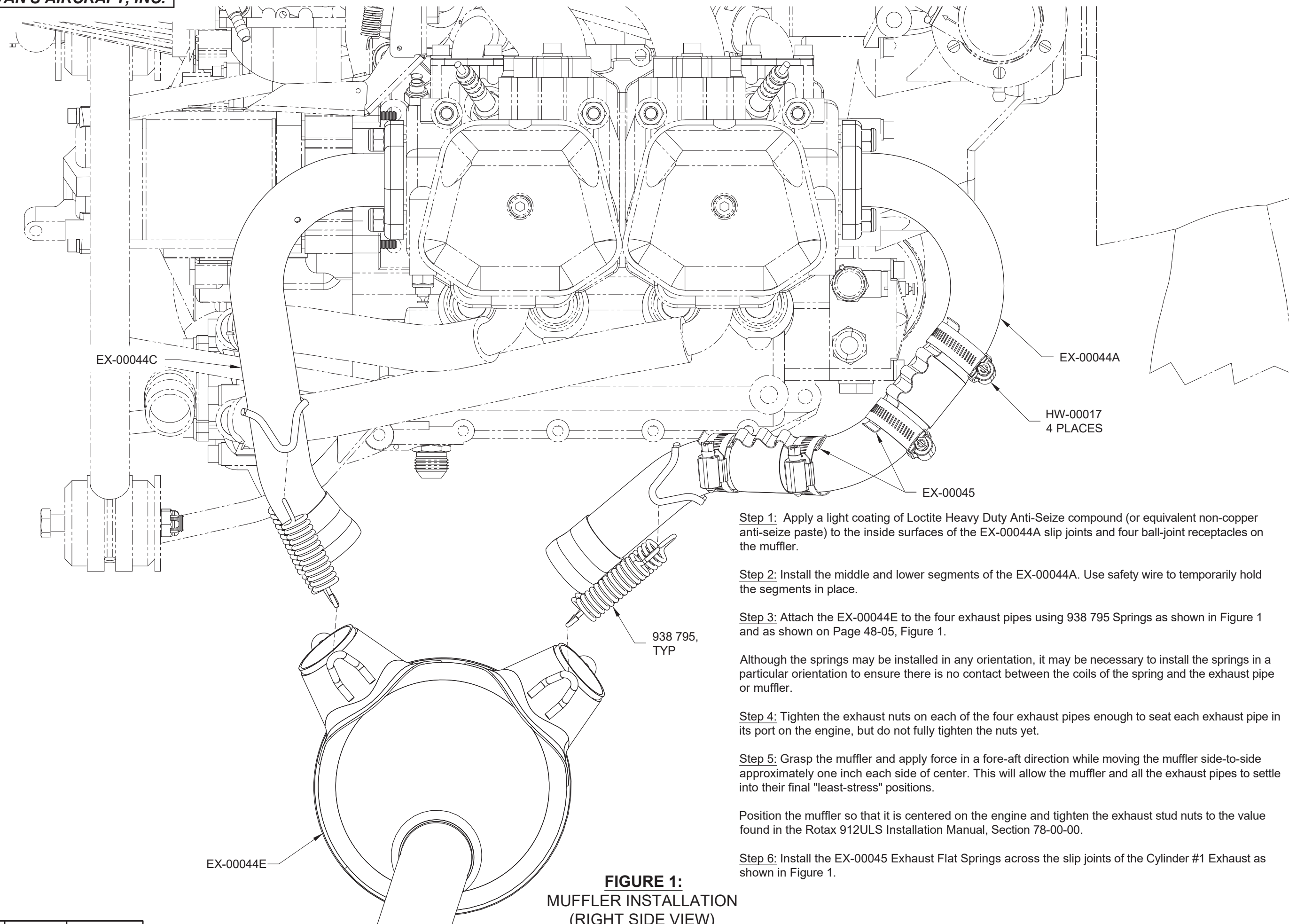

Step 1: Apply a light coating of Loctite Heavy Duty Anti-Seize compound (or equivalent non-copper anti-seize paste) to the inside surfaces of the EX-00044A slip joints and four ball-joint receptacles on the muffler.

Step 2: Install the middle and lower segments of the EX-00044A. Use safety wire to temporarily hold the segments in place.

Step 3: Attach the EX-00044E to the four exhaust pipes using 938 795 Springs as shown in Figure 1 and as shown on Page 48-05, Figure 1.

Although the springs may be installed in any orientation, it may be necessary to install the springs in a particular orientation to ensure there is no contact between the coils of the spring and the exhaust pipe or muffler.

Step 4: Tighten the exhaust nuts on each of the four exhaust pipes enough to seat each exhaust pipe in its port on the engine, but do not fully tighten the nuts yet.

Step 5: Grasp the muffler and apply force in a fore-aft direction while moving the muffler side-to-side approximately one inch each side of center. This will allow the muffler and all the exhaust pipes to settle into their final "least-stress" positions.

Position the muffler so that it is centered on the engine and tighten the exhaust stud nuts to the value found in the Rotax 912ULS Installation Manual, Section 78-00-00.

Step 6: Install the EX-00045 Exhaust Flat Springs across the slip joints of the Cylinder #1 Exhaust as shown in Figure 1.

FIGURE 1:
MUFFLER INSTALLATION
(RIGHT SIDE VIEW)

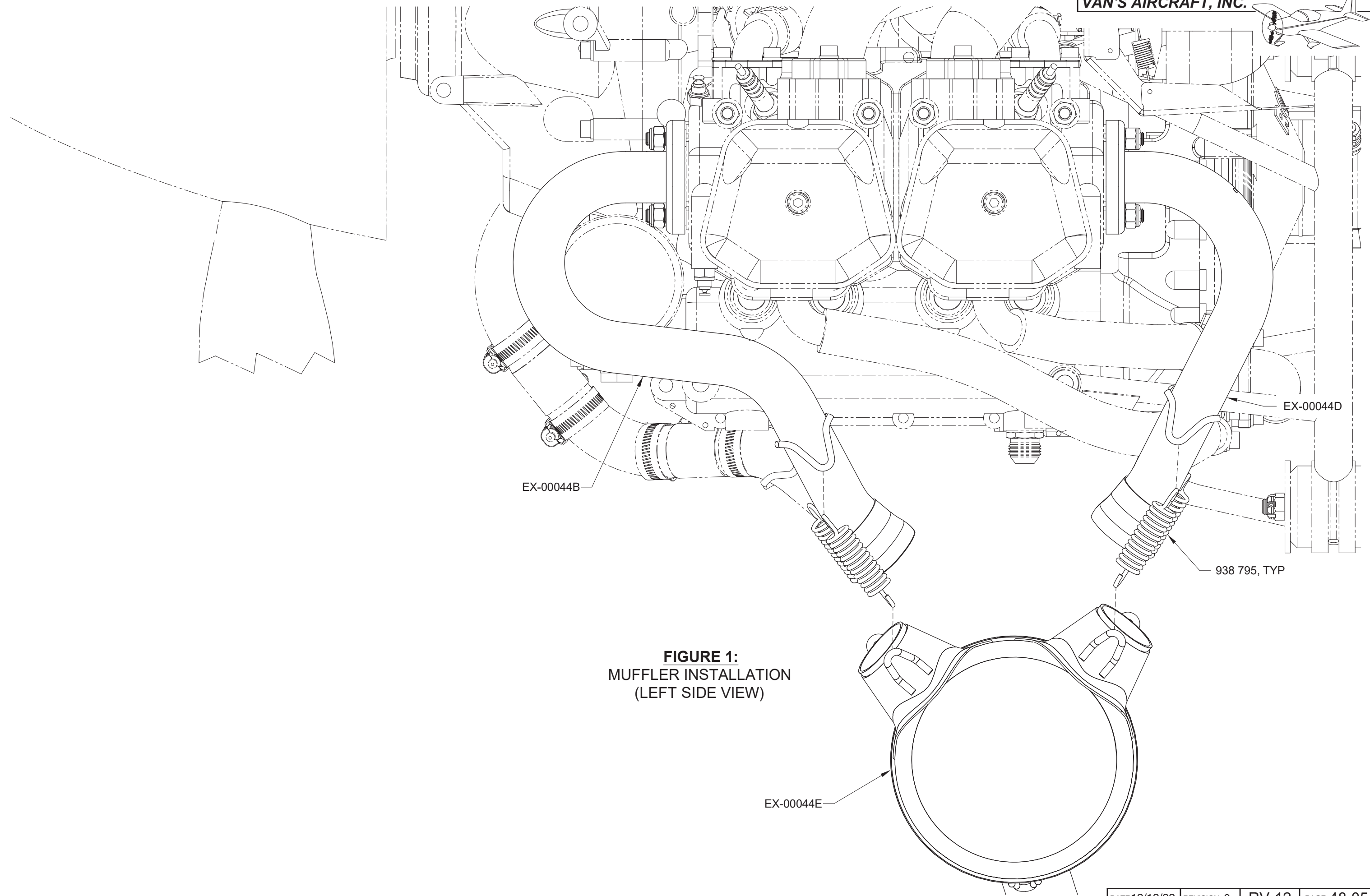
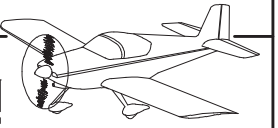
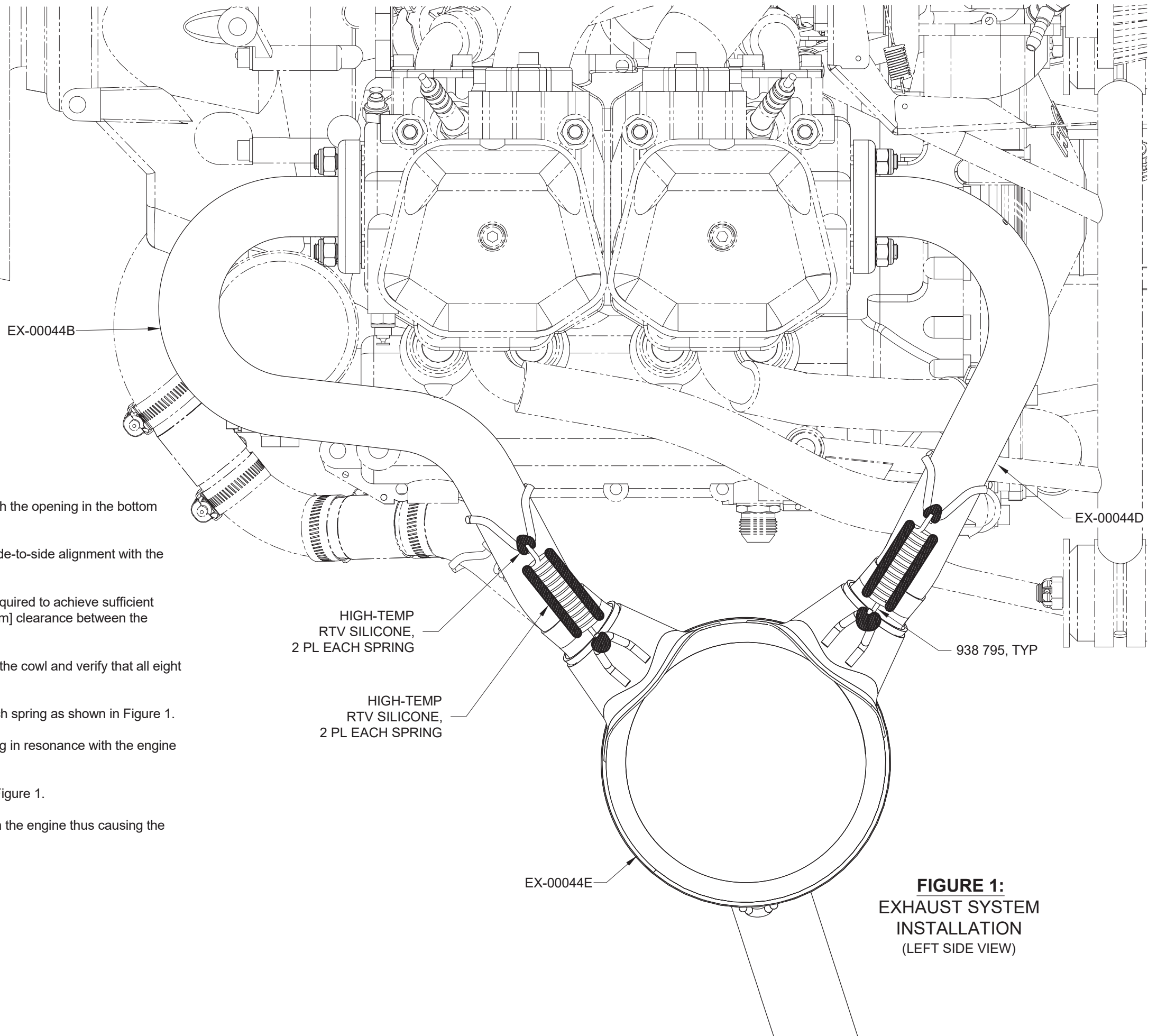
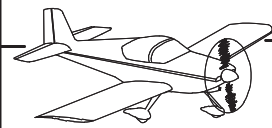

FIGURE 1:
MUFFLER INSTALLATION
(LEFT SIDE VIEW)



Step 1: Install the bottom cowl. Check that the exhaust pipe lines-up with the opening in the bottom cowl.

Adjust the side-to-side position of the muffler if/as required to achieve side-to-side alignment with the cowl opening.

Enlarge the exhaust pipe opening in the bottom cowl forward or aft as required to achieve sufficient opening to install/remove the cowl and to provide at least 3/4 in. [19.1 mm] clearance between the exhaust pipe and the edge of the opening in the cowl when installed.

When satisfied with the fit of the bottom cowl and exhaust pipe, remove the cowl and verify that all eight exhaust nuts are properly torqued.

Step 2: Apply a bead of RTV Sealant to the forward and aft sides of each spring as shown in Figure 1.

Applying a bead of RTV to both sides of the spring keeps it from vibrating in resonance with the engine thus causing contact wear or premature failure of the spring.

Step 3: Place a small amount of RTV over the spring ends as shown in Figure 1.

RTV on the spring ends keeps the spring from rotating in resonance with the engine thus causing the "hooks" on the exhaust pipes and muffler to wear

FIGURE 1:
EXHAUST SYSTEM
INSTALLATION
(LEFT SIDE VIEW)

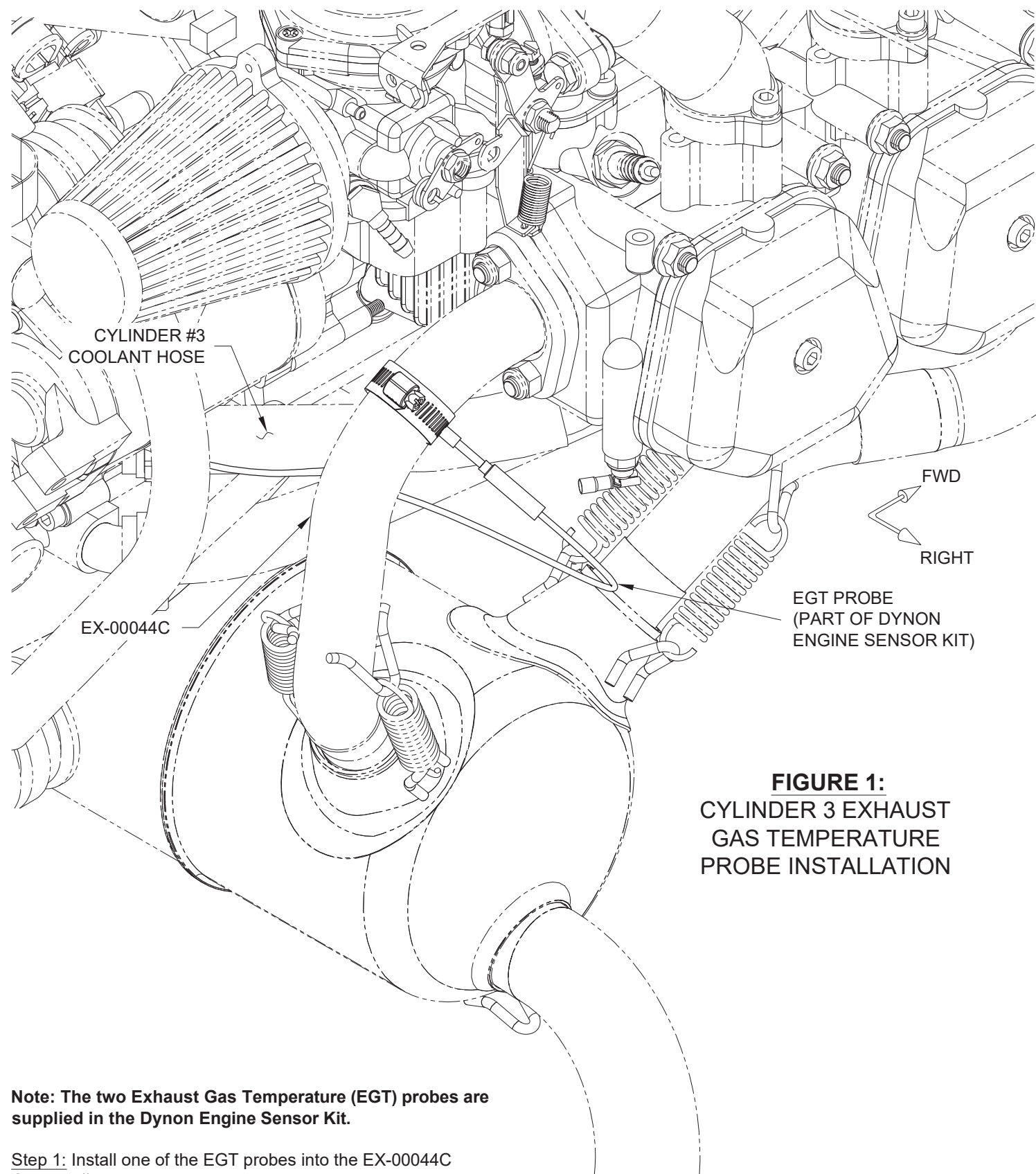
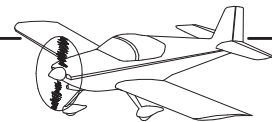

FIGURE 1:
CYLINDER 3 EXHAUST
GAS TEMPERATURE
PROBE INSTALLATION

Note: The two Exhaust Gas Temperature (EGT) probes are supplied in the Dynon Engine Sensor Kit.

Step 1: Install one of the EGT probes into the EX-00044C Cylinder #3 Exhaust as shown in Figure 1.

The EGT probe wire is routed from the exhaust along the cylinder #3 coolant hose aft and inboard to where it then follows the gascolator to fuel pump hose upward to the top of the engine where its spade connectors are mated to the EGT-R wires coming from the aft side of the firewall.

The EGT probe wire follows the routing of the CHT-R and oil pressure transducer wires and is secured to the engine using the same tie-wraps.

Step 2: Install the remaining EGT probe into the EX-00044D as shown in Figure 2.

The EGT probe wire is routed from the exhaust along the left carburetor fuel hose (not shown in Figure 2) upward and inboard to the top of the engine where it then follows the gascolator to fuel pump hose aft and down to the point where its spade connectors are mated to the EGT-L wires coming from the aft side of the firewall.

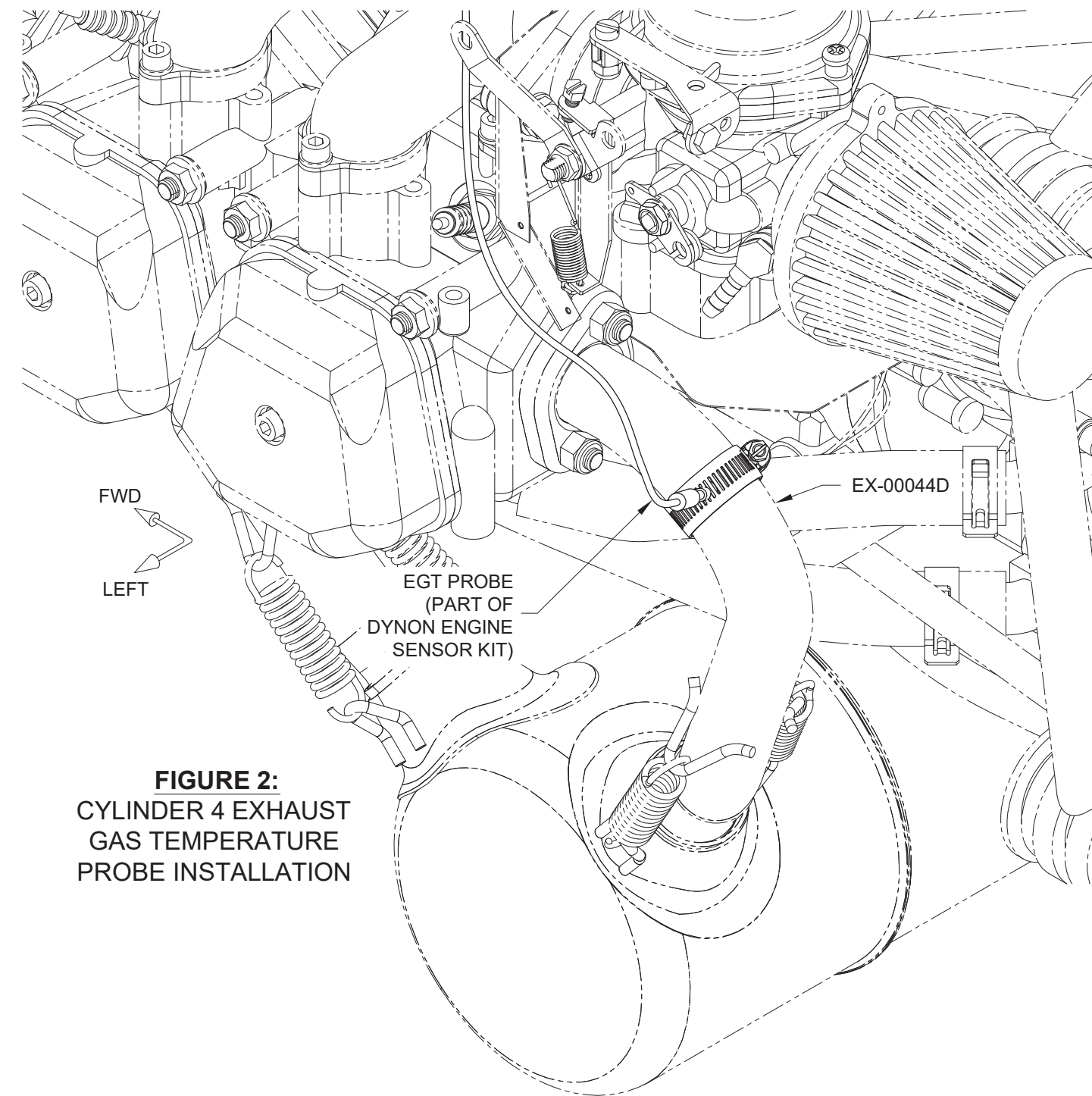
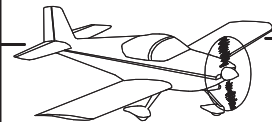

FIGURE 2:
CYLINDER 4 EXHAUST
GAS TEMPERATURE
PROBE INSTALLATION



THIS PAGE INTENTIONALLY LEFT BLANK