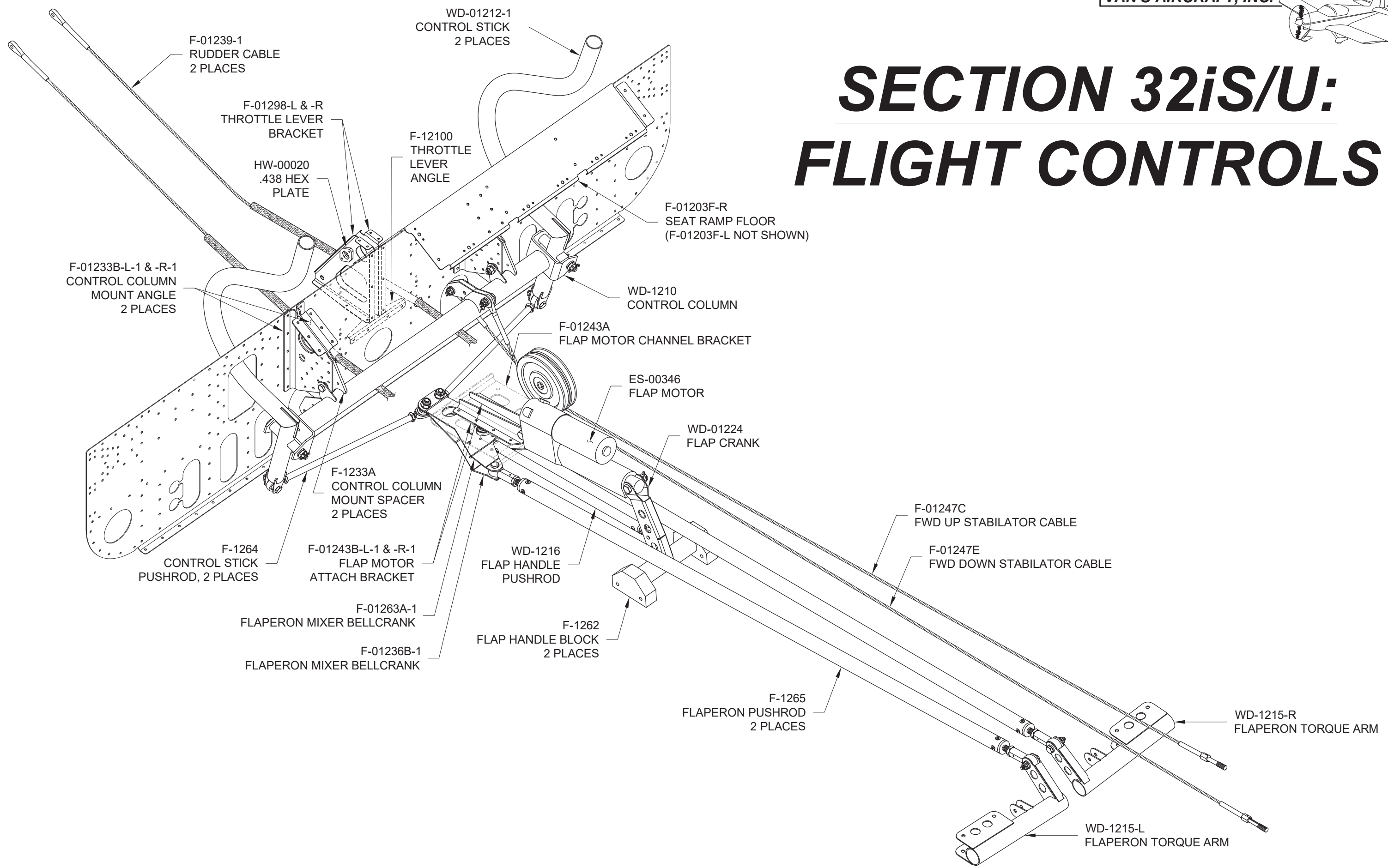


# SECTION 32iS/U: FLIGHT CONTROLS



DATE OF COMPLETION: _____			
PARTICIPANTS: _____			
DATE: 12/12/22	REVISION: 2	RV-12iS	PAGE: 32iS/U-01



Step 1: Bolt the VA-107 Brake Reservoir to the F-01201A-1 as shown in Figure 1.

Step 2: After coating the external threads with pipe thread sealant, thread the FLF-00004 into the VA-107 as shown in Figure 2.

Step 3: Mark the free ends of the F-1289A-L & -R 1/2 in. [12.7 mm] from the end of each line.

Step 4: Insert the free ends of the F-1289A-L & -R into the FLF-00004 up to the marks as shown in Figure 2. The marks must reach/touch the ends of the FLF-00004.

Step 5: Secure the F-1289A-L & -R and F-1289B-L & -R (the four brake lines attached to the right side master cylinders) to the bottom of the F-01202B-1 as shown in Figure 2.

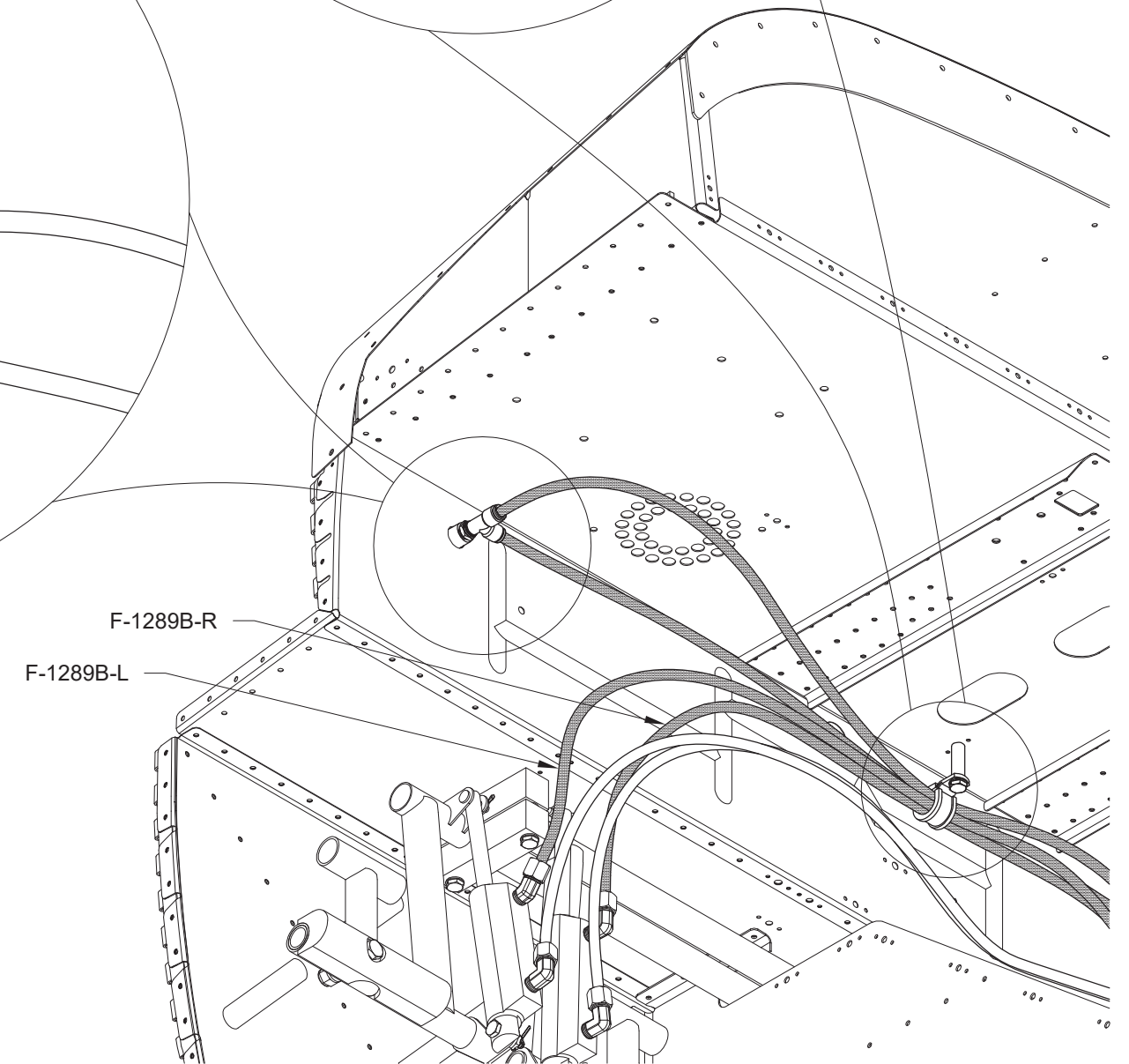
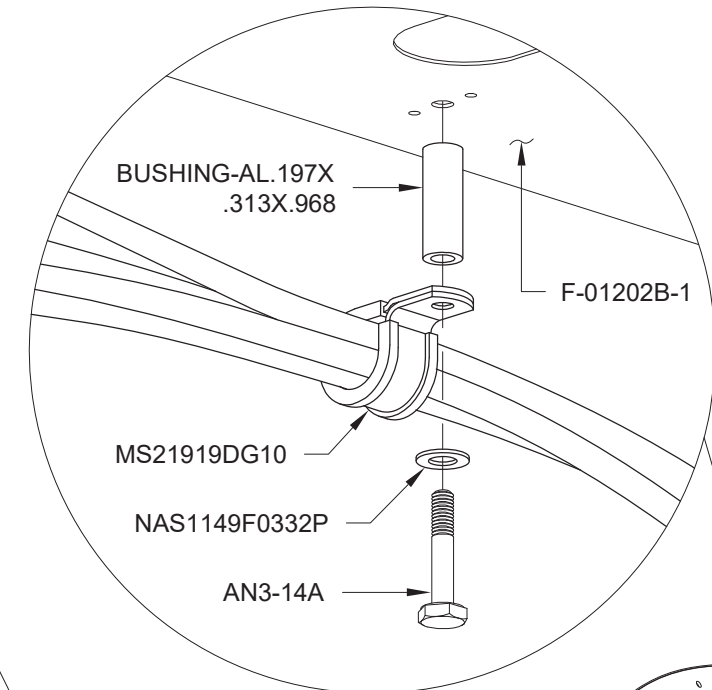
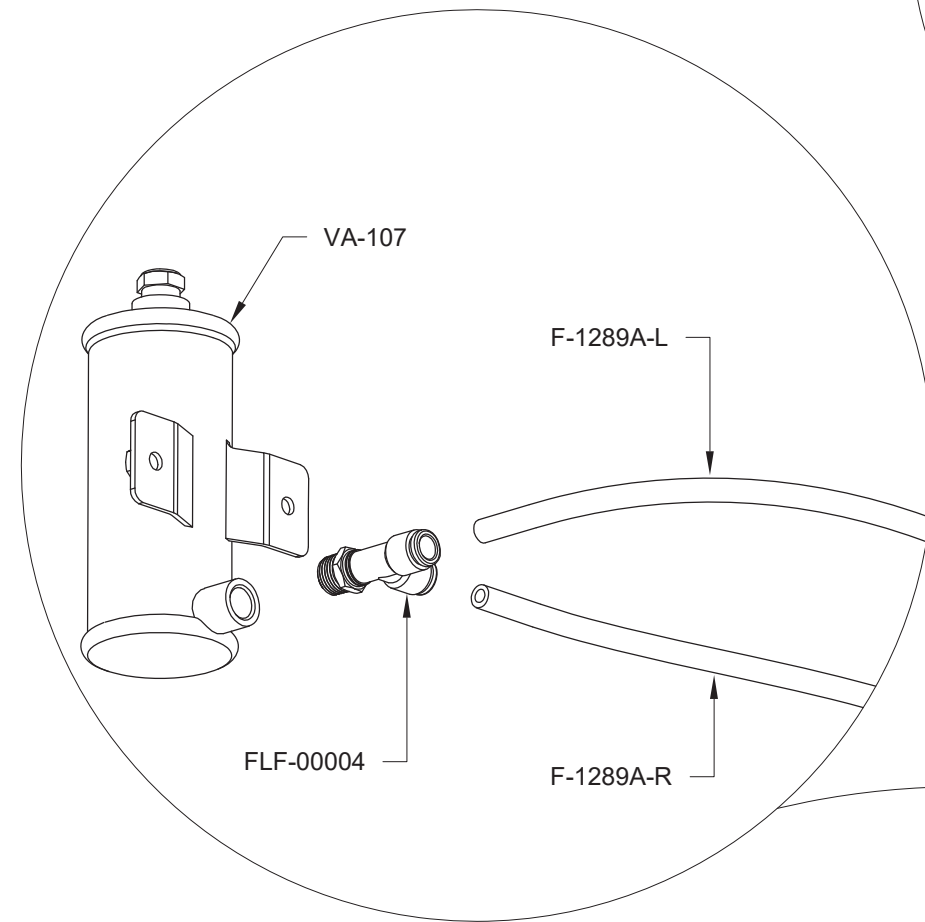
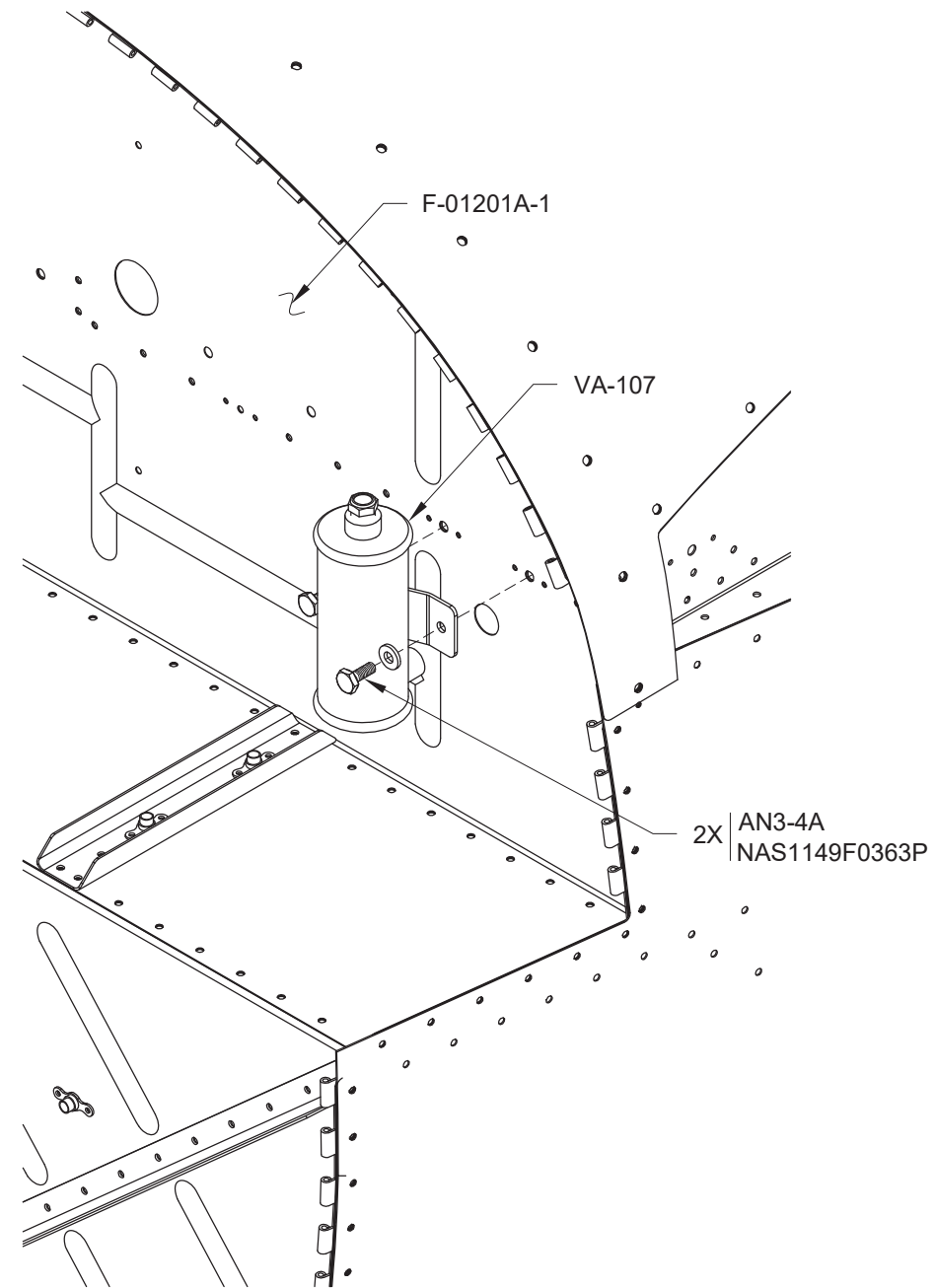


FIGURE 1: ATTACHING THE BRAKE RESERVOIR

FIGURE 2: SECURING THE BRAKE LINES



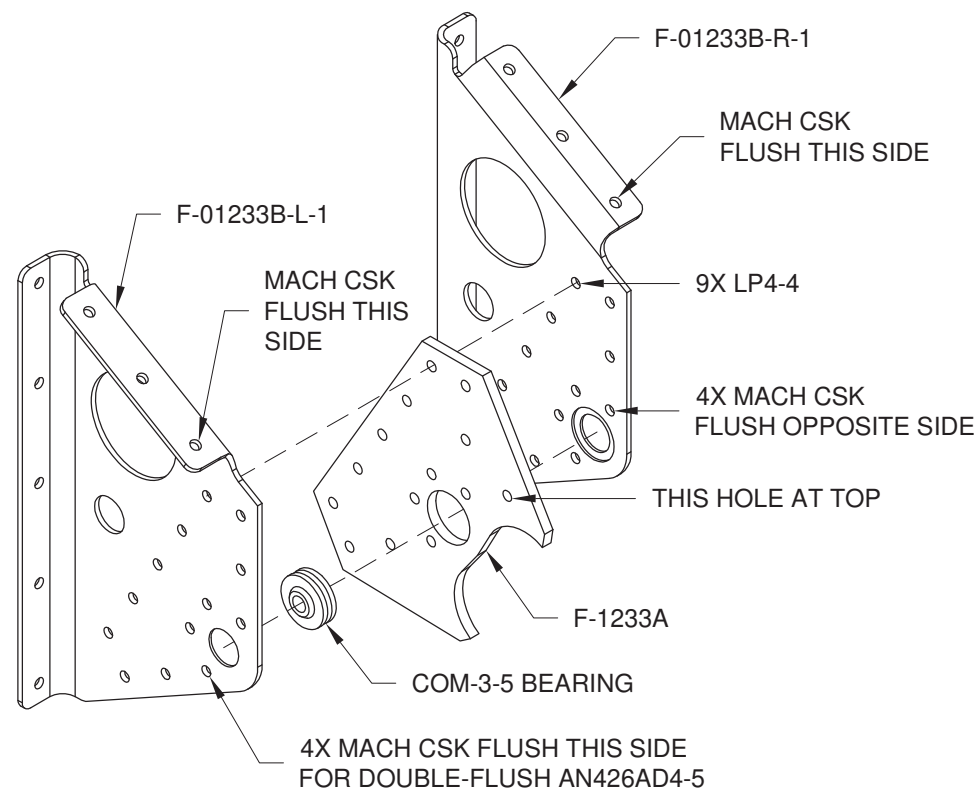
**NOTE: Use the parts shown in Figure 1 to produce two Control Column Mount Assemblies as follows:**

**Step 1:** Carefully deburr the edges and holes of the F-1233A and F-01233B-L-1 & -R-1 so that the parts fit together tightly.

**Step 2:** Machine countersink the four holes surrounding the bearing hole in each F-01233B-L-1 & -R-1 for the double flush rivets called out.

Machine countersink the indicate #30 hole in the sloped flange of the F-01233B-L-1 & -R-1 for the dimples in the F-01203F (see Page 32iS/U-09).

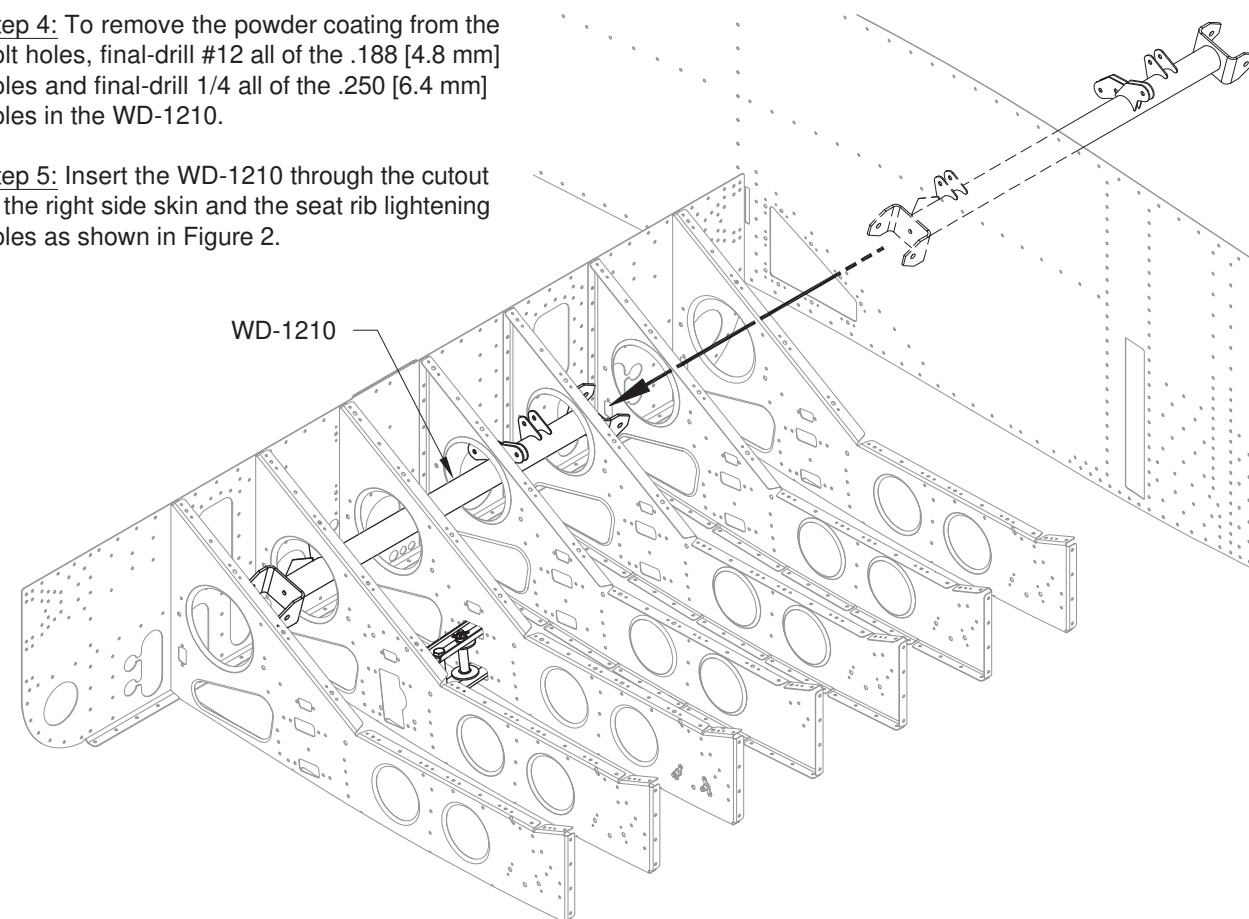
**Step 3:** Assemble and rivet the parts as shown. Note the location of the indicated hole that orients the top of the F-1233A.



**FIGURE 1: CONTROL COLUMN MOUNT ASSEMBLY (TWO ASSEMBLIES REQUIRED)**

**Step 4:** To remove the powder coating from the bolt holes, final-drill #12 all of the .188 [4.8 mm] holes and final-drill 1/4 all of the .250 [6.4 mm] holes in the WD-1210.

**Step 5:** Insert the WD-1210 through the cutout in the right side skin and the seat rib lightening holes as shown in Figure 2.

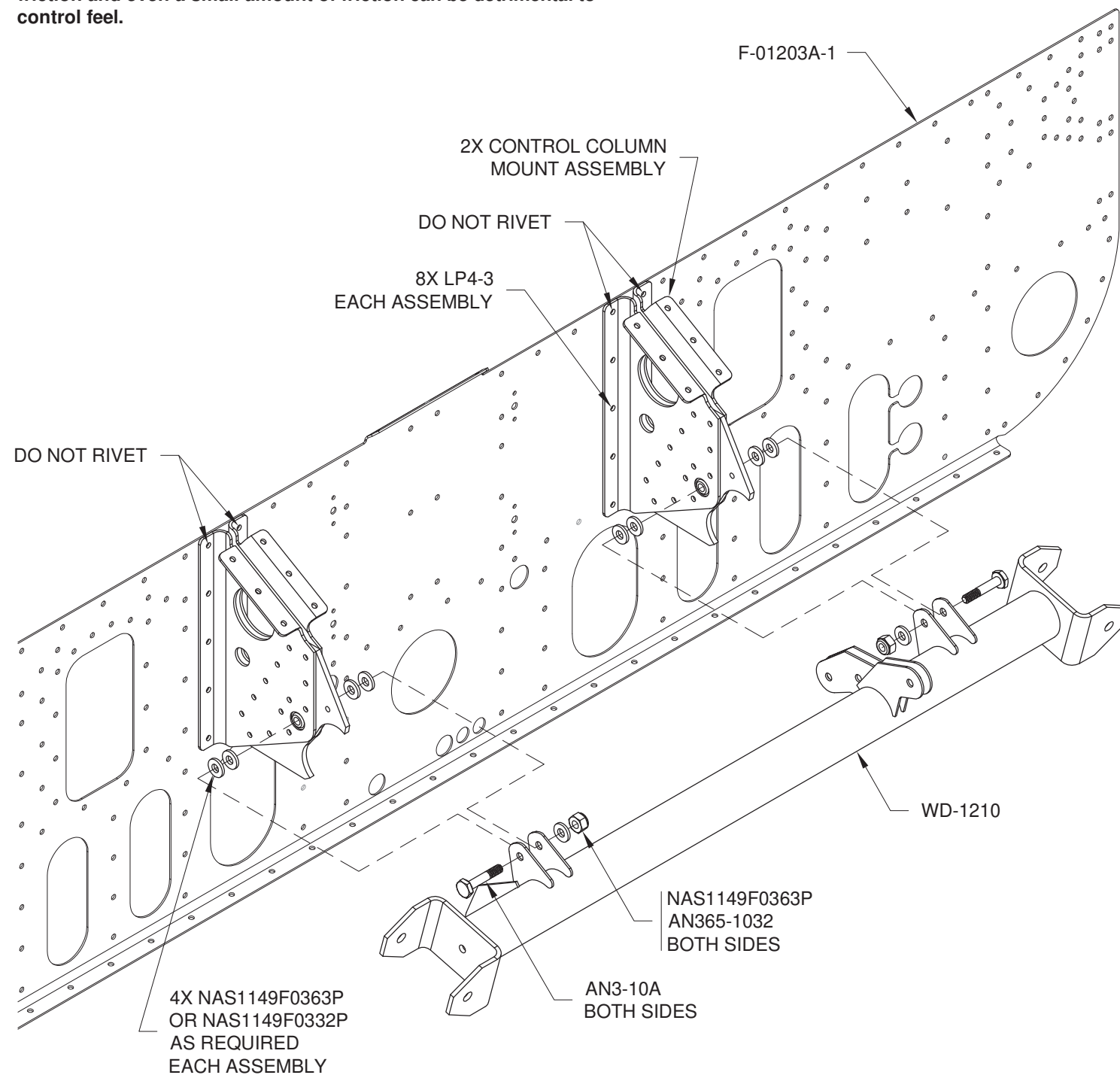


**FIGURE 2: INSERTING THE CONTROL COLUMN**

**Step 6:** Except for the indicated top holes, rivet the Control Column Mount Assemblies to the F-01203A-1 Bulkhead as shown in Figure 3. Place the manufactured heads on the bulkhead.

**Step 7:** Attach the WD-1210 to the Control Column Mount Assemblies as shown in Figure 3. Use the thick/thin washers to adjust the spacing in order to minimize the side load on the bearings after the bolts are torqued. Small pieces of tape can be used to hold the washer pairs during installation. Attach one side first, then the other side.

**NOTE: A small side load on a bearing can dramatically increase friction and even a small amount of friction can be detrimental to control feel.**



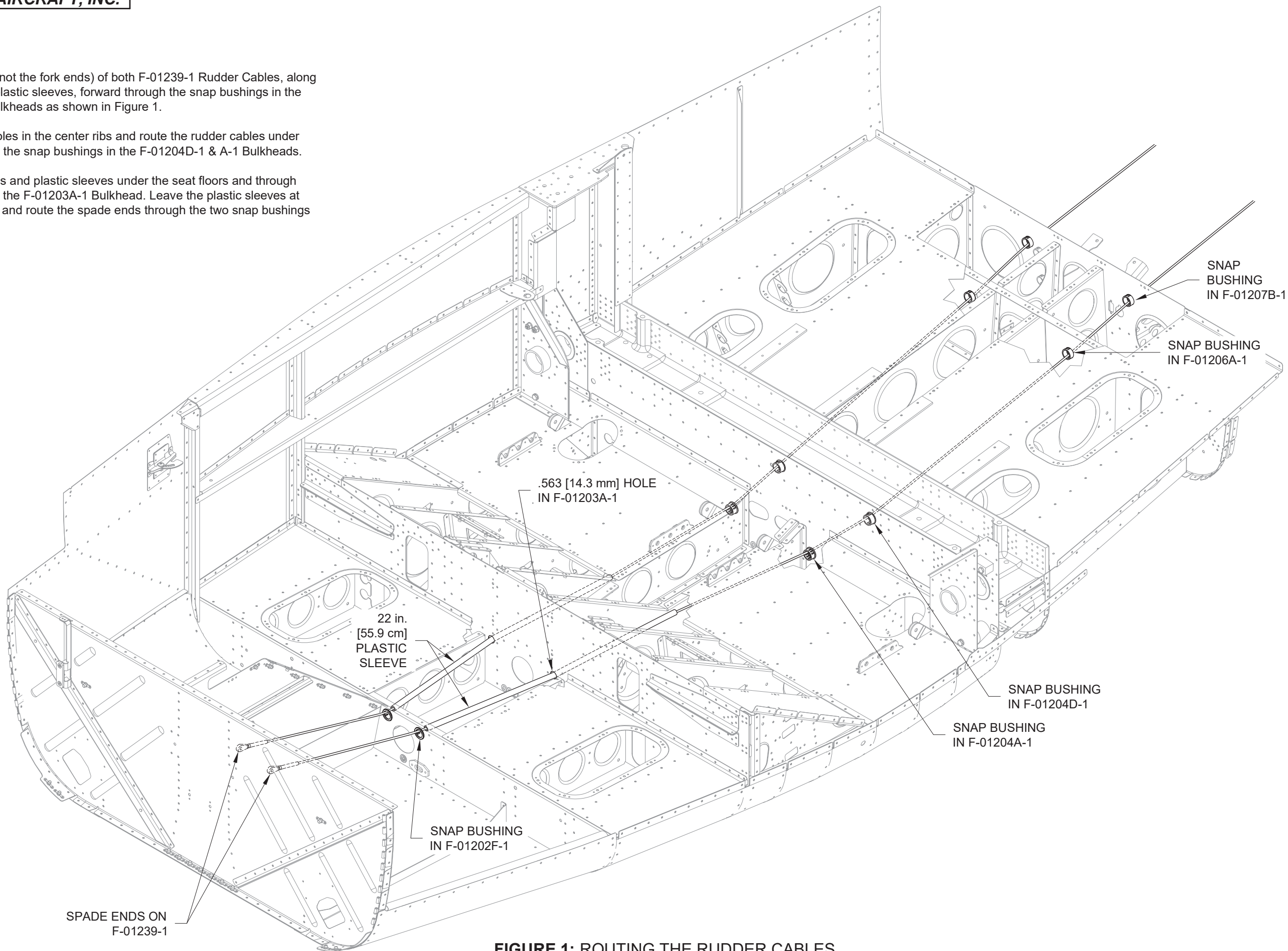
**FIGURE 3: ATTACHING THE CONTROL COLUMN**



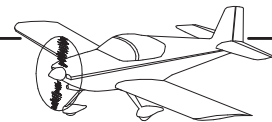
Step 1: Route the spade ends (not the fork ends) of both F-01239-1 Rudder Cables, along with their 22 in [55.9 cm] long plastic sleeves, forward through the snap bushings in the F-01207B-1 and F-01206A-1 Bulkheads as shown in Figure 1.

Reach through the lightening holes in the center ribs and route the rudder cables under the baggage floors and through the snap bushings in the F-01204D-1 & A-1 Bulkheads.

Continue routing the spade ends and plastic sleeves under the seat floors and through the two .563 [14.3 mm] holes in the F-01203A-1 Bulkhead. Leave the plastic sleeves at the locations shown in Figure 1 and route the spade ends through the two snap bushings in the F-01202F-1 Bulkheads.

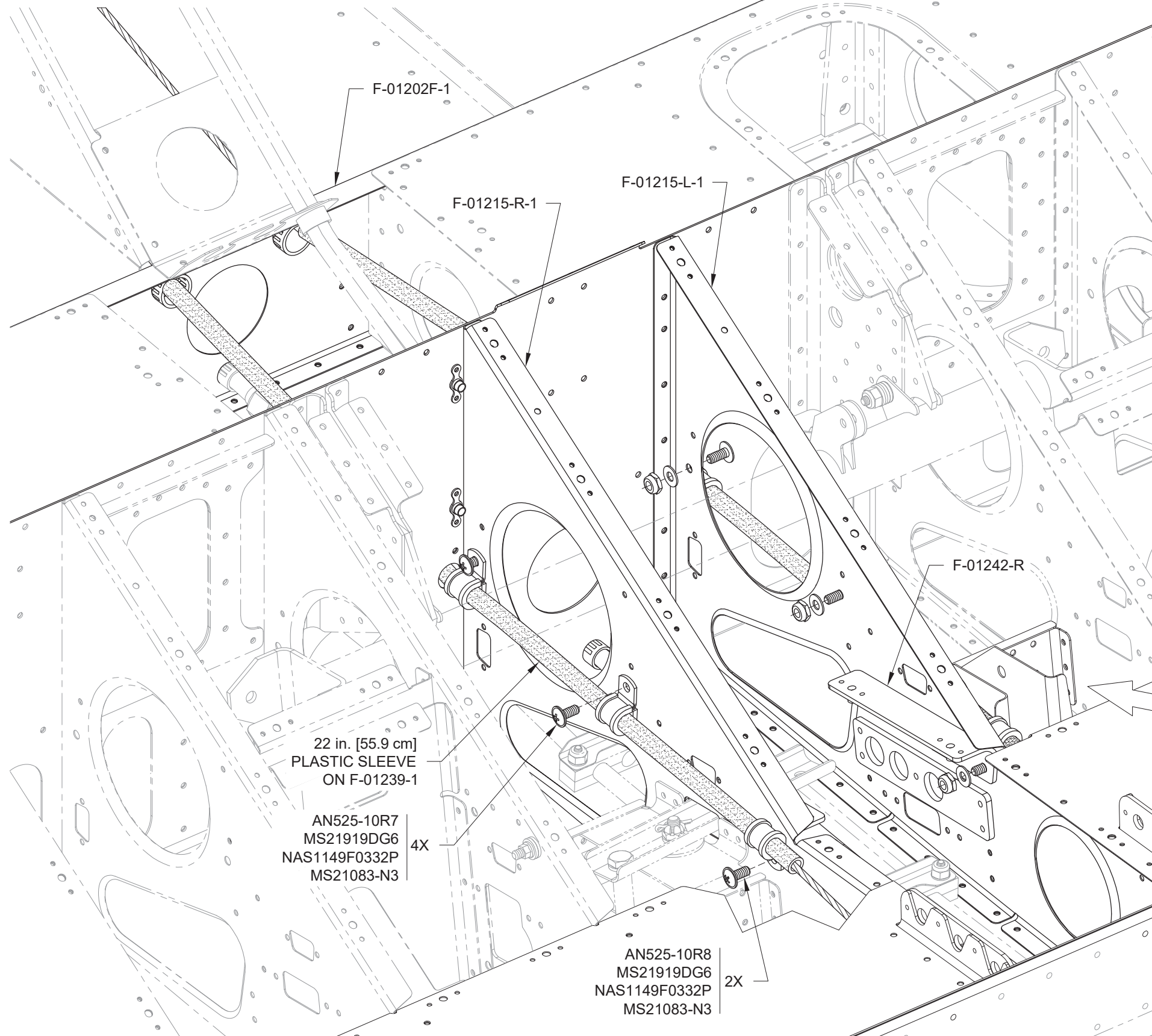


**FIGURE 1: ROUTING THE RUDDER CABLES**



Step 1: Install the bushing shown in Figure 3 between the F-1250-L & -R using the hardware called out.

Step 2: Slide both 22 in. [55.9 cm] plastic sleeves forward along the F-01239-1 Rudder Cables until they contact the aft end of the snap bushings in the F-01202F-1, then secure them to the F-01215-L-1 & -R-1 as shown in Figure 1. Note the orientation of the aft cushioned clamps that get attached to the F-01242-L & -R.

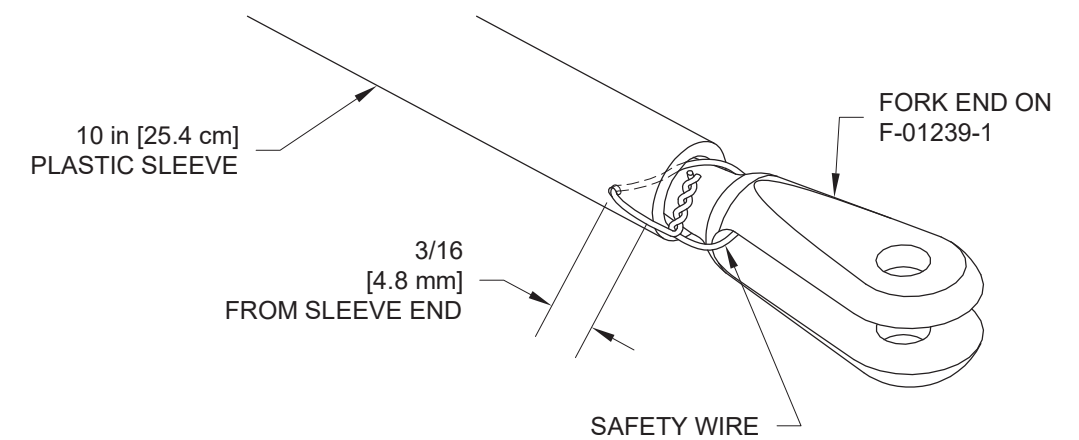


**FIGURE 1: SECURING THE RUDDER CABLE FORWARD PLASTIC SLEEVES**

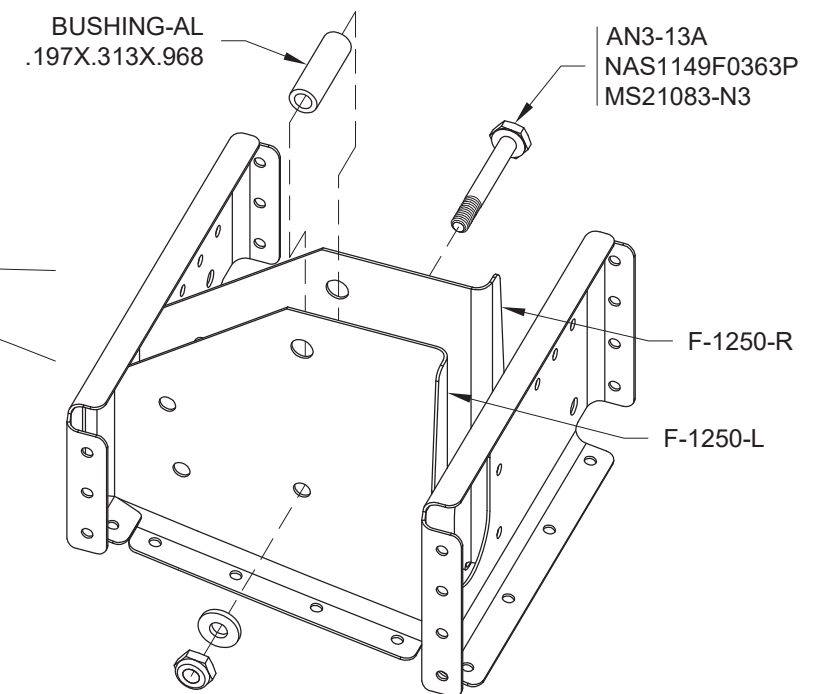
Step 3: Drill #40 both of the 10 in. [25.4 cm] plastic sleeves on the aft end of the rudder cables as shown in Figure 2.

Step 4: Pull the plastic sleeves over the shaft of the fork ends and safety wire them to the fork ends as shown.

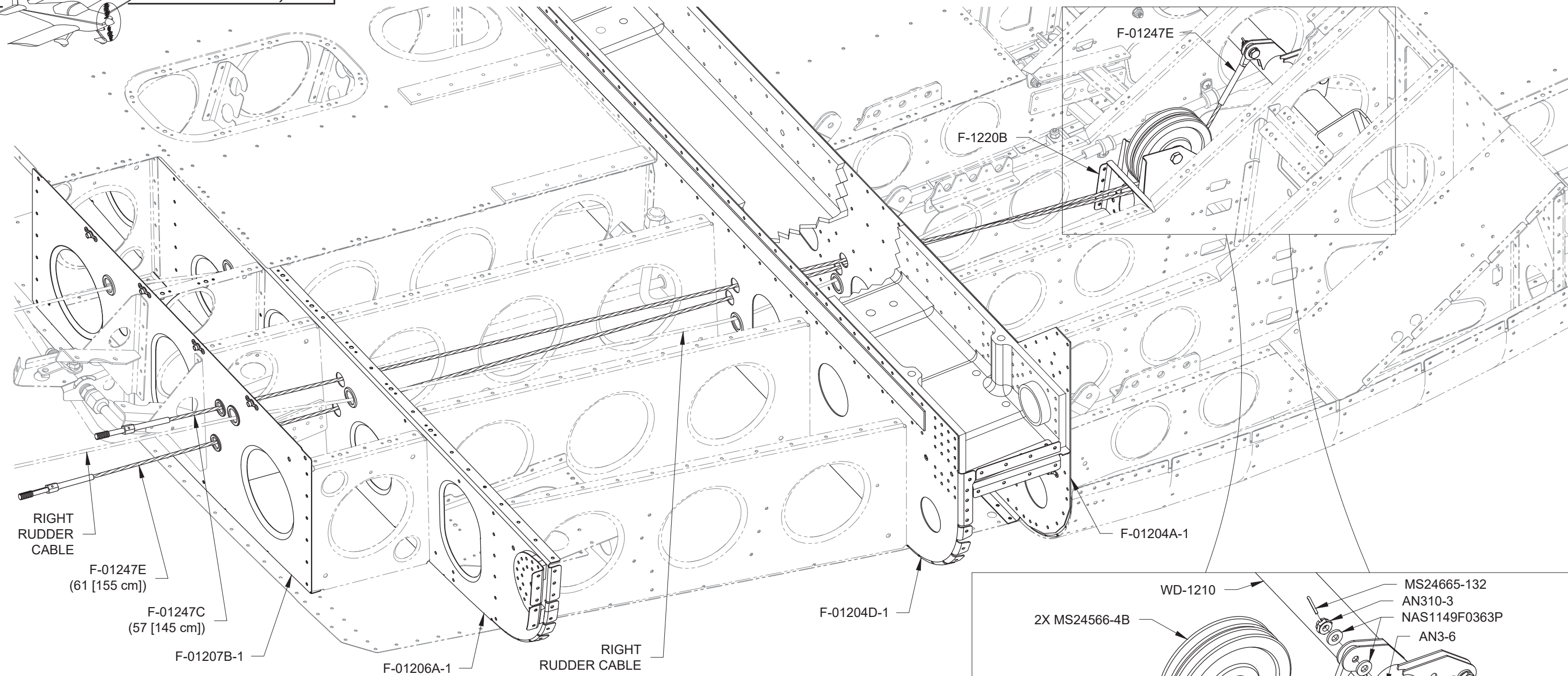
Step 5: Coil the aft ends of the rudder cables and secure them just forward of the F-01207B-1 Bulkhead for later attachment. Secure the forward ends of the rudder cables forward of the F-01202F-1 Bulkhead. See Page 32iS/U-04, Figure 1 for bulkhead locations.



**FIGURE 2: SAFETY WIRING THE RUDDER CABLE AFT PLASTIC SLEEVES**



**FIGURE 3: INSTALLING THE CABLE RETAINER BUSHING**



**Step 1:** Route the forward ends of the F-01247C & E Stabilator Cables through the holes in the F-01207B-1, F-01206A-1, F-01204D-1, and F-01204A-1 Bulkheads, through the hole in the F-1220B, and over the cable retainer bushing as shown in Figure 1 and the detail view of Figure 1.

**Step 2:** As required, use a mirror and a flashlight to verify that the F-01247C & E are routed properly (i.e. verify that they are not crossed, and that they do not interfere with the rudder cables).

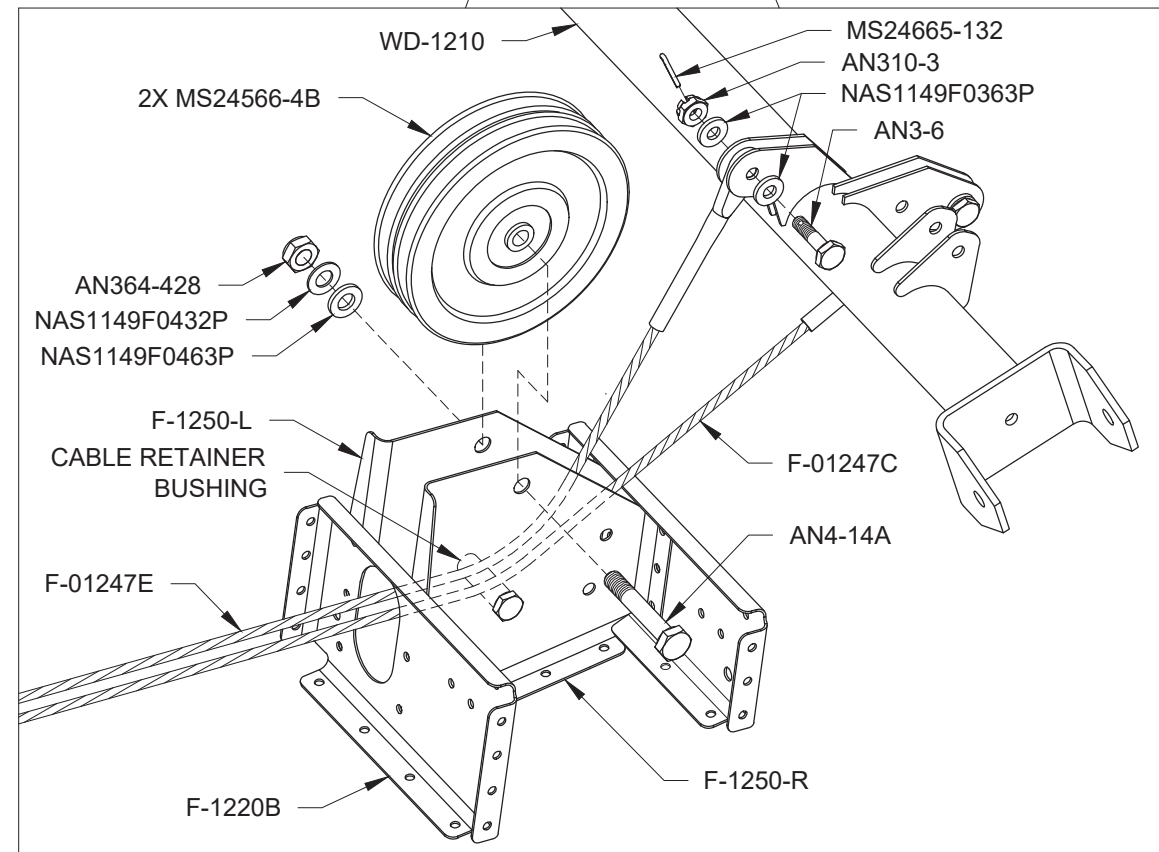
**NOTE:** "See Fasteners As Pivot Points" in Section 5.20 for information on cable end attachment hardware.

**Step 3:** Secure the stabilator cables to the WD-1210 using the hardware called out.

**Step 4:** Install the two pulleys; be sure the stabilator cables are captured between the cable retainer bushing and the pulleys.

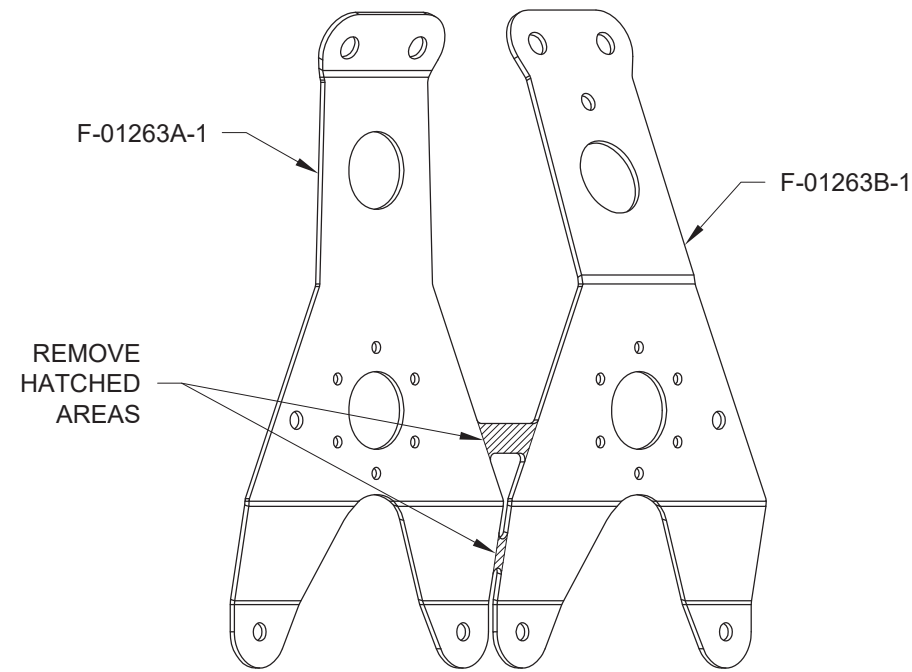
**Step 5:** Pull the aft end of the stabilator cables forward of the F-01207B-1 Bulkhead and store them there until they are attached in Section 38iS/U.

**FIGURE 1: FORWARD STABILATOR CABLES**





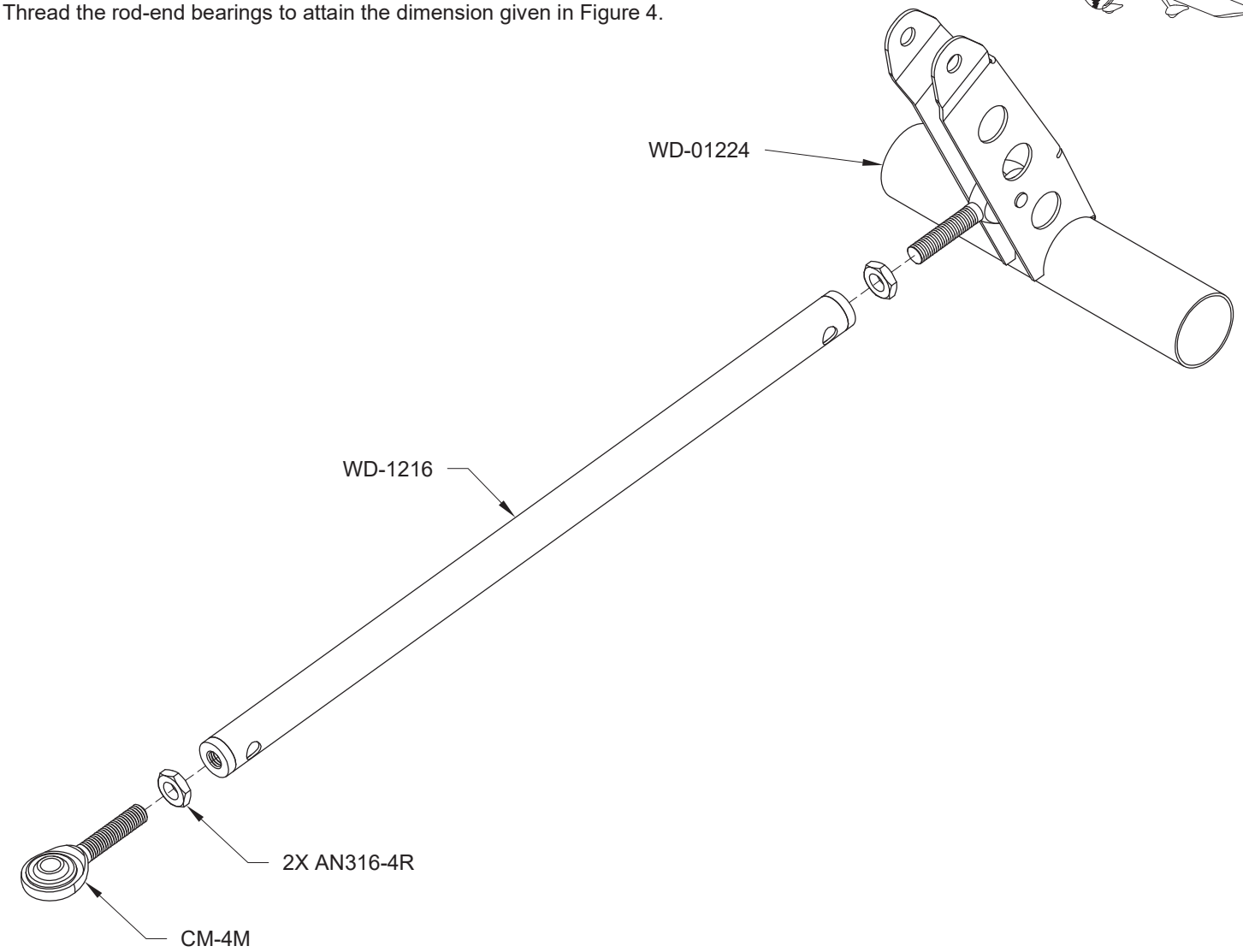
Step 1: Separate the F-01263-1 Flaperon Mixer Bellcrank into individual parts by removing the hatched areas shown in Figure 1.



**FIGURE 1: SEPARATING THE FLAPERON MIXER BELLCRANK**

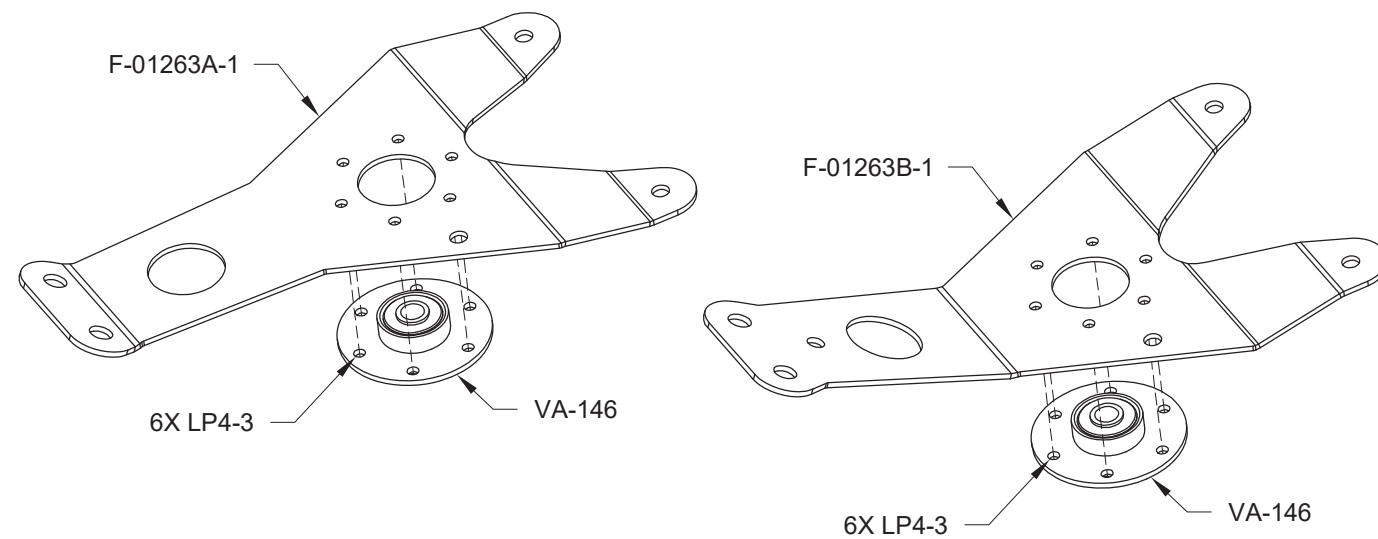
Step 3: Make the Flap Crank Assembly as shown in Figure 3.

Thread the rod-end bearings to attain the dimension given in Figure 4.

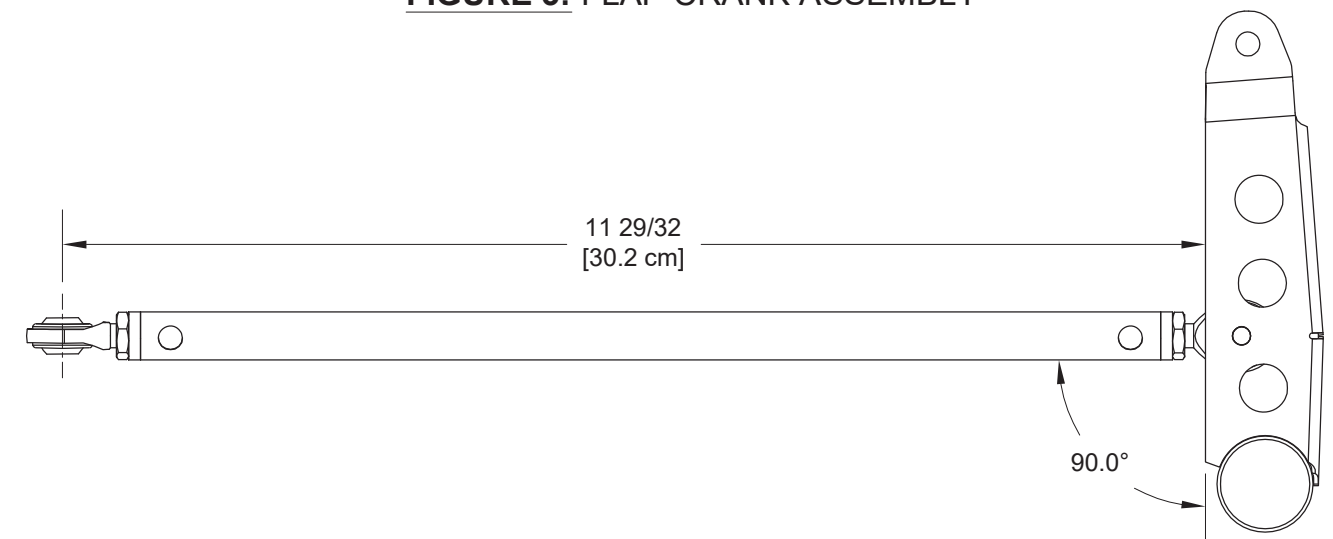


**FIGURE 3: FLAP CRANK ASSEMBLY**

Step 2: Rivet the VA-146 Flange Bearings to the F-01263A-1 & B-1 as shown in Figure 2.



**FIGURE 2: ATTACHING THE FLANGE BEARINGS**



**FIGURE 4: FLAP CRANK ASSEMBLY PUSHROD LENGTH**



Step 2: Secure the Flap Crank Assembly to the inboard F-01215-L-1 & -R-1 using the F-1262 as shown in Figure 2.

Step 3: Attach the F-01263A-1 & B-1 and Flap Crank Assembly to the F-01219A-1 & B-1 (previously installed in Section 21iS/U) as shown in Figure 2.

Step 1: Trim the corners from the two F-1262 as shown in Figure 1.

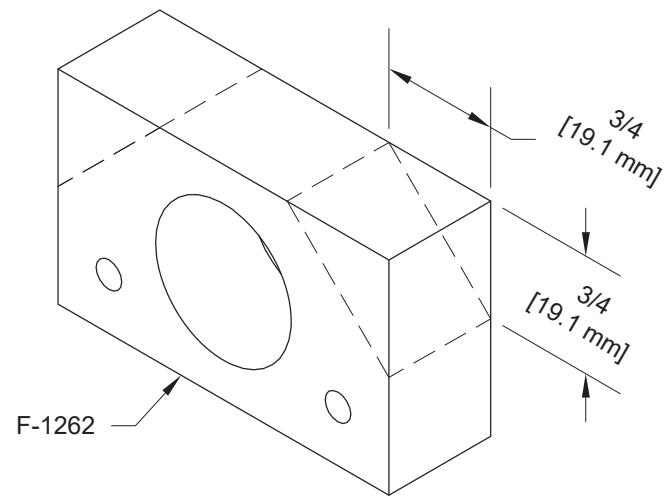


FIGURE 1: TRIMMING THE FLAP HANDLE BLOCKS

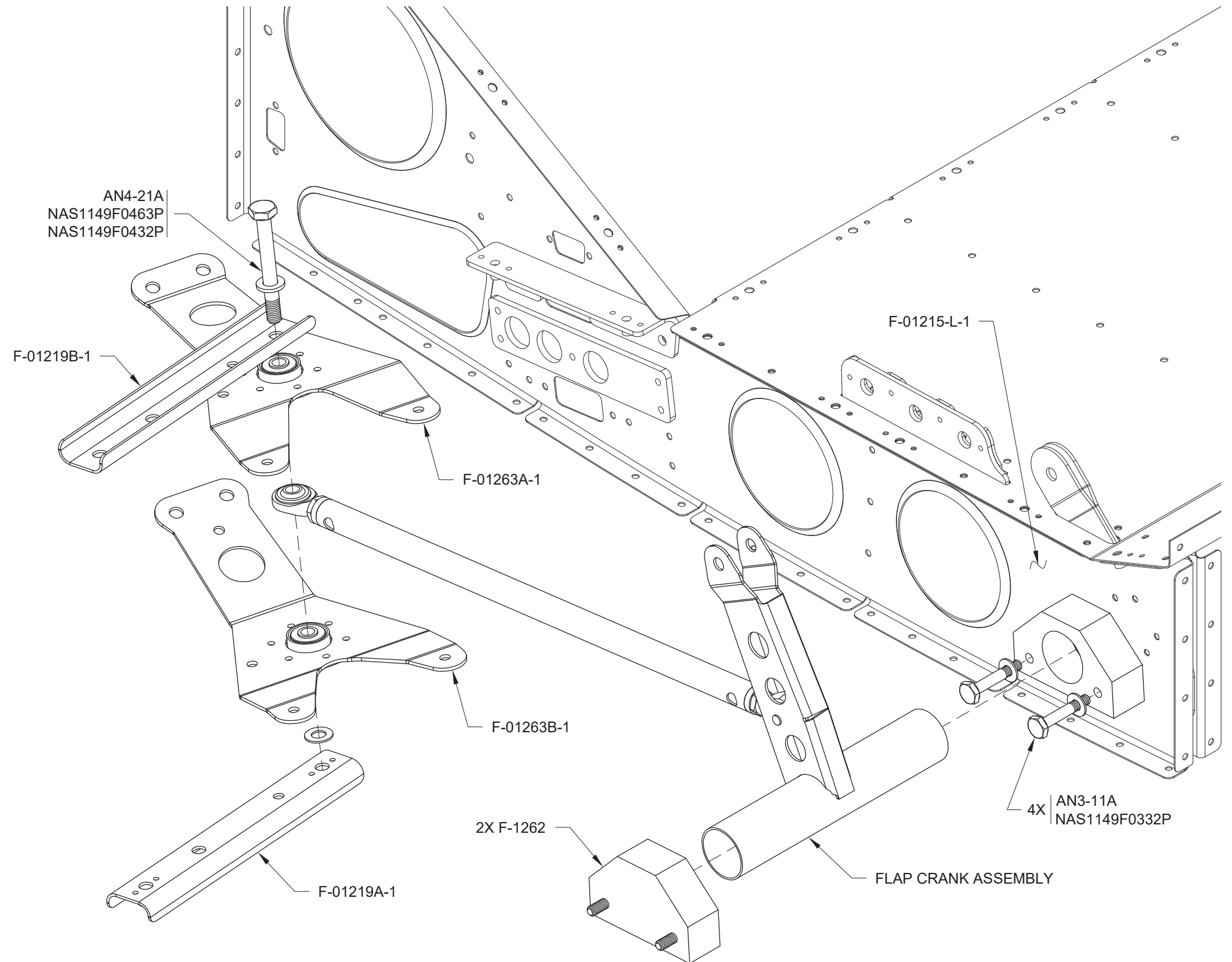
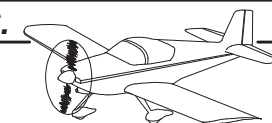


FIGURE 2: INSTALLING THE FLAP CRANK ASSEMBLY





Step 1: Dimple and machine countersink the F-01203F-L & -R as called out in Figure 1. Apply call-outs to both parts.

Step 2: Dimple the F-01298-L as called out in Figure 1.

Step 3: File the hex-hole in the HW-00020 as necessary to accept the head of the bolt shown in Figure 1. Set the bolt aside; it will be installed in the Powerplant Kit.

Machine countersink the HW-00020 for the dimples in the F-012098-L, then rivet in place.

Step 4: Rivet the nutplates along the aft edge of the F-01203F-L & -R.

Step 5: Rivet the F-01203F-L & -R (including the forward flange) to the fuselage. Rivet the forward inboard nutplates.

Step 6: Rivet the F-12100 to the F-01298-L & -R.

Step 7: Rivet the F-12100 and F-01298-L & -R to the F-01203A-1.

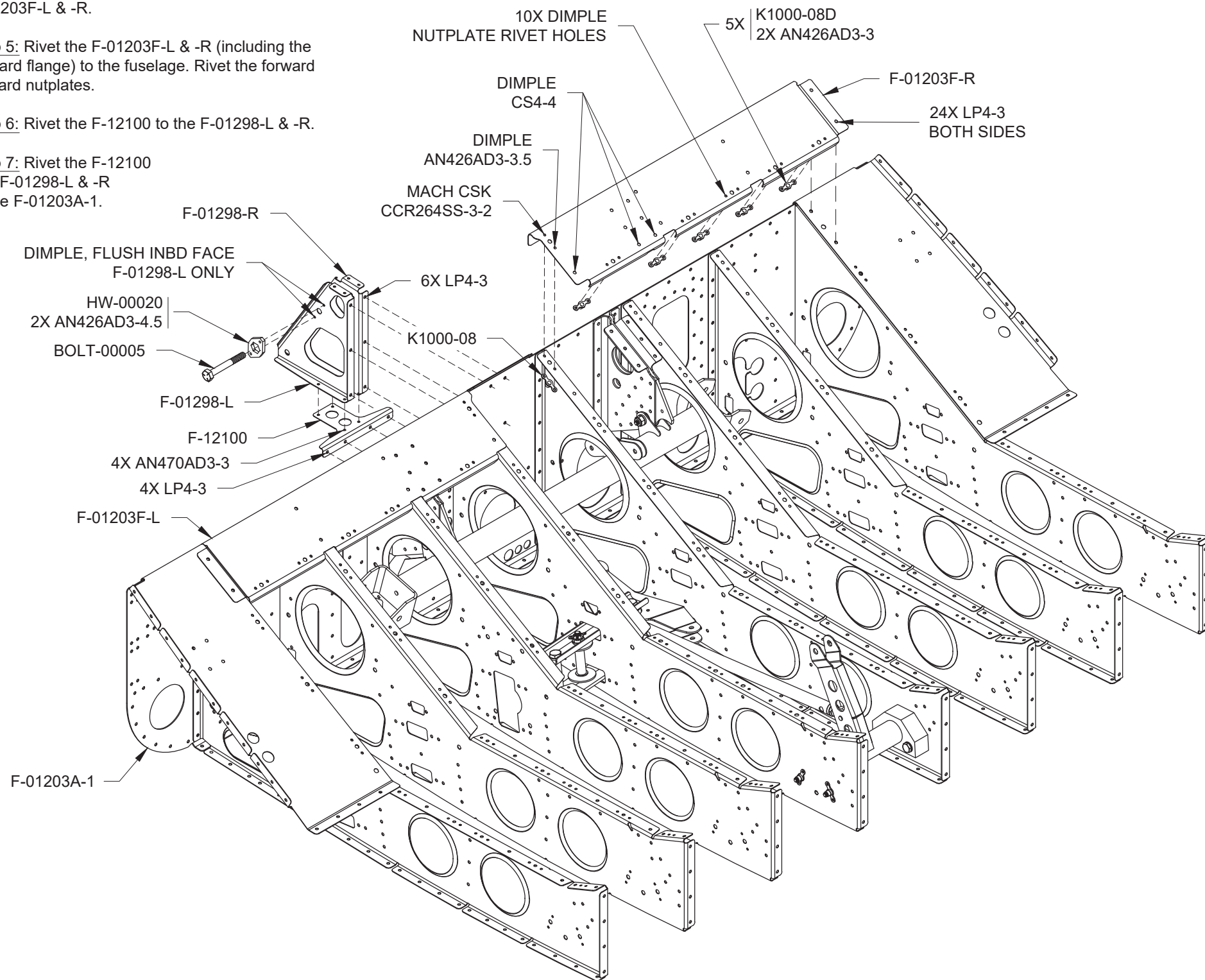


FIGURE 1: ATTACHING THE SEAT RAMP FLOORS & THROTTLE LEVER BRACKETS

Step 8: Fabricate two F-1264 from AT6-058X5/16 as shown in Figure 2.

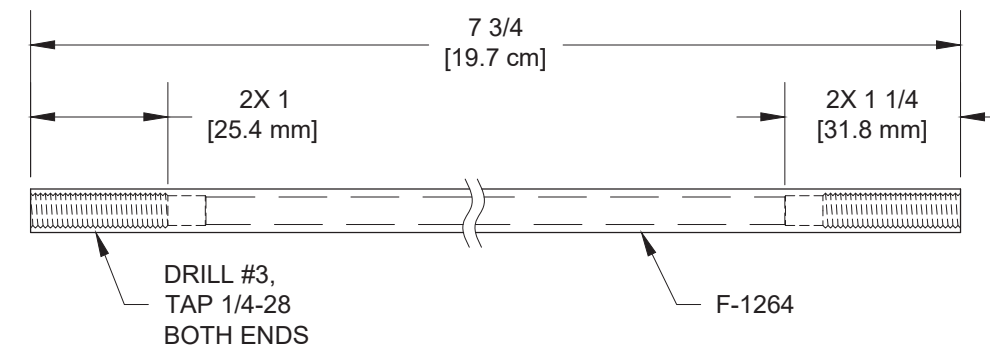


FIGURE 2: FABRICATING THE CONTROL STICK PUSHRODS

CAUTION: Ensure the CM-4MS body, and NOT the stud, is threaded into the pushrod as shown.

Step 9: Fabricate two Control Stick Pushrod Assemblies as shown in Figure 3.

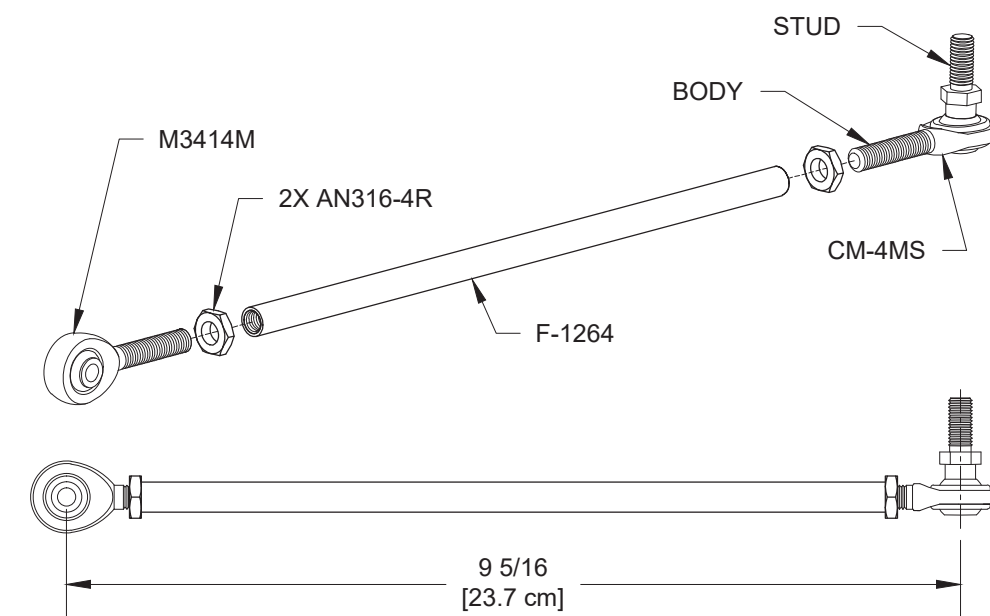


FIGURE 3: CONTROL STICK PUSHROD ASSEMBLY (TWO ASSEMBLIES REQUIRED)



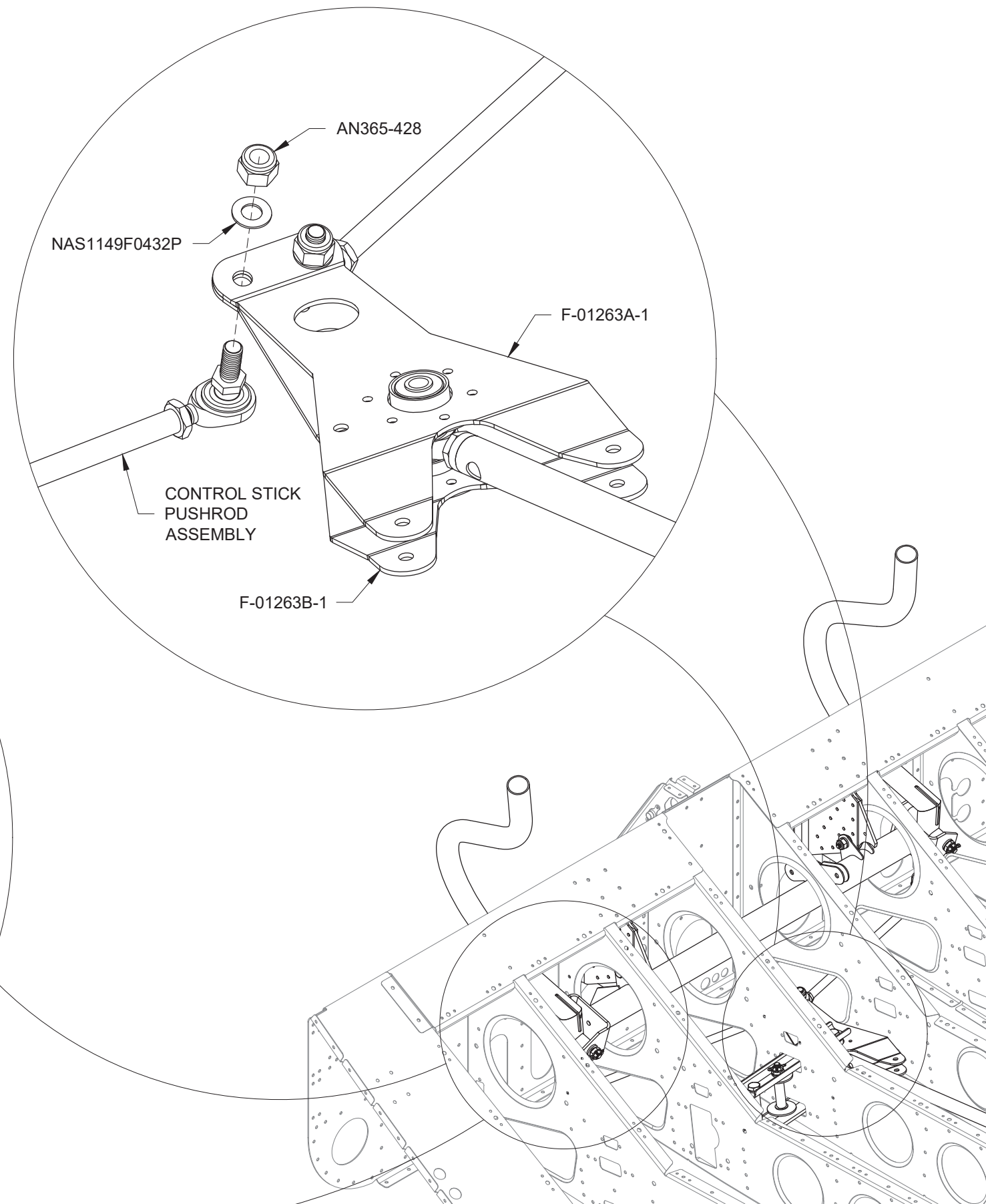
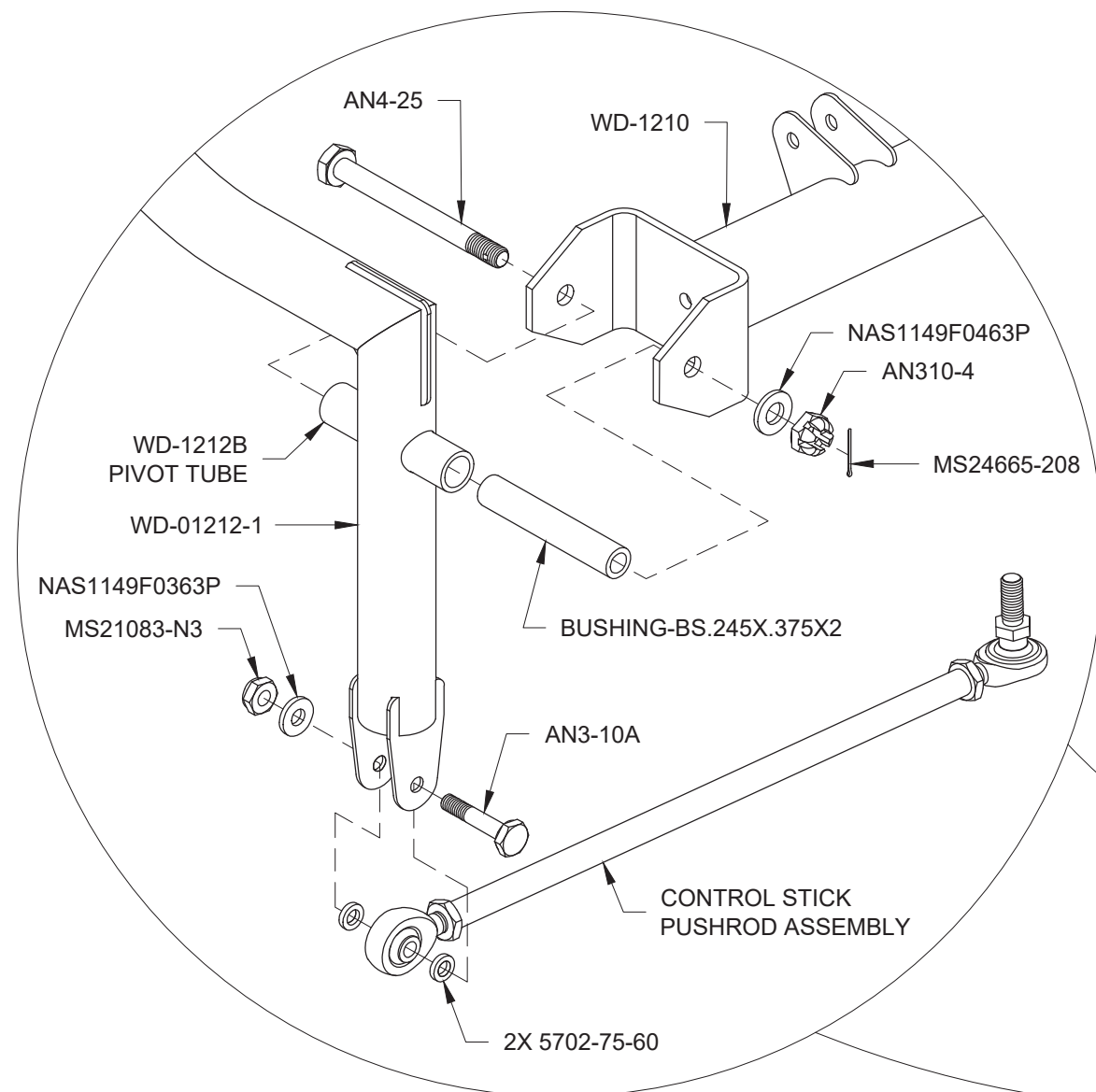
**Step 1:** Clamp two BUSHING-BS.245X.375X2 Brass Bushings in a bench vise (be careful not to over-tighten or gouge the bushings), then drill 1/4 through the inside diameters.

**Step 2:** Use a file to progressively remove material from both bushings until they fit snugly between the brackets on either end of the WD-1210.

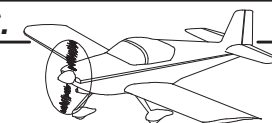
**Step 3:** Use a file to progressively remove material from the ends of the WD-1212B pivot tubes until they are slightly shorter than the bushings; the brackets on the WD-1210 are to clamp on the bushings and just clear the pivot tubes.

**Step 4:** Attach both WD-01212-1 to the WD-1210 as shown in Figure 1. Apply just enough torque to clamp the bushings and stop them from rotating.

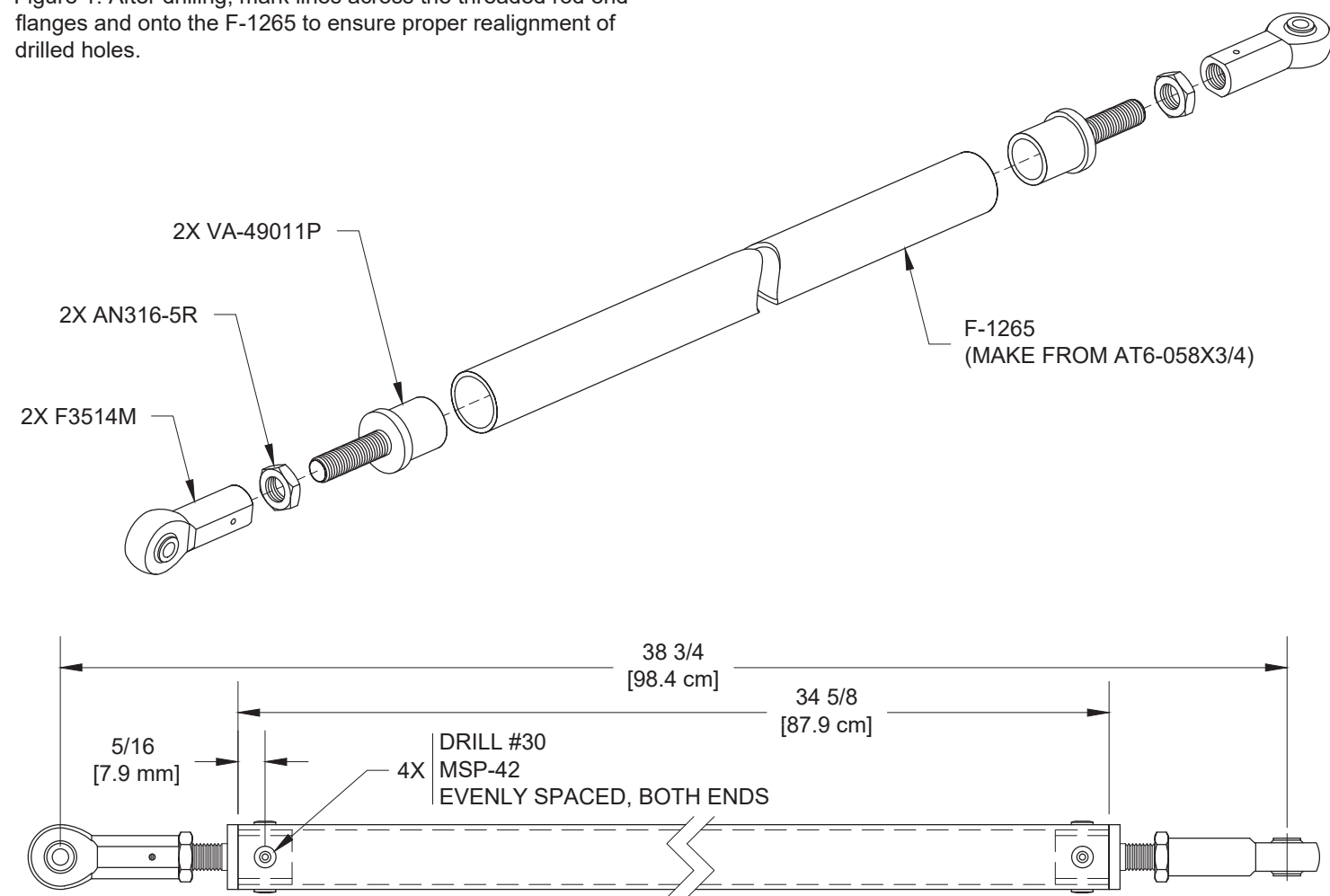
**Step 5:** Attach the Control Stick Pushrod Assemblies to the WD-01212-1s and the F-01263A-1 & B-1 as shown.



**FIGURE 1: ATTACHING THE CONTROL STICKS**



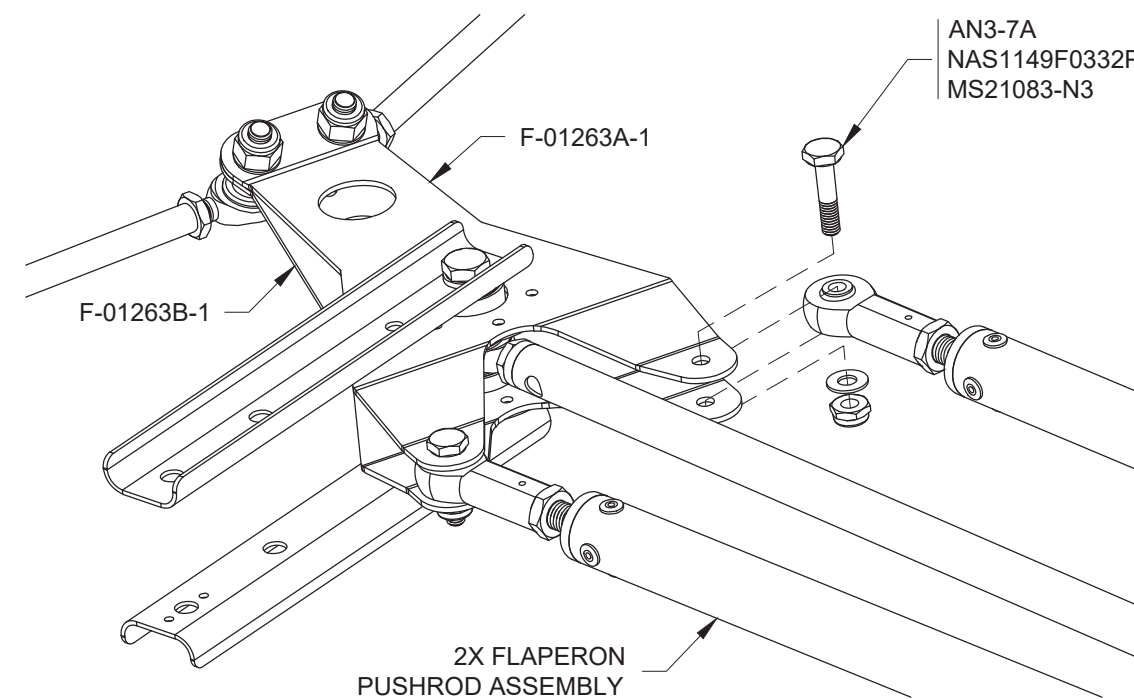
Step 1: Fabricate two Flaperon Pushrod Assemblies as shown in Figure 1. After drilling, mark lines across the threaded rod end flanges and onto the F-1265 to ensure proper realignment of drilled holes.



**FIGURE 1: FLAPERON PUSHROD ASSEMBLY**  
(TWO REQUIRED)

Step 2: Pass the two Flaperon Pushrod Assemblies through their corresponding oblong holes in the center section bulkheads and the center lightening hole in the F-01206A-1.

Step 3: Attach the forward end of each Flaperon Pushrod Assembly to the F-01263A-1 & B-1 as shown in Figure 2.

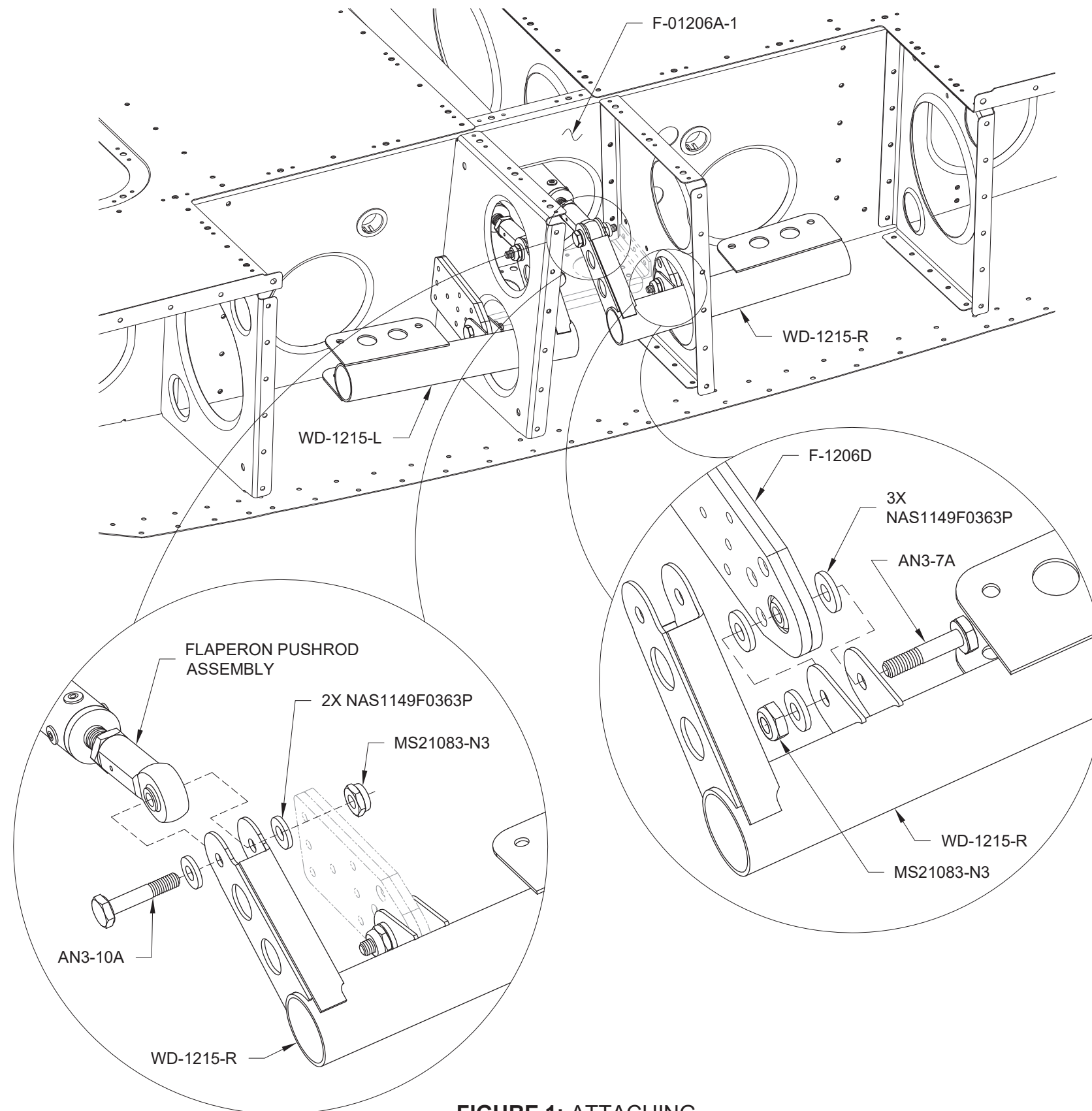


**FIGURE 2: ATTACHING THE FLAPERON PUSHROD ASSEMBLIES**

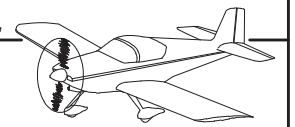


Step 1: Attach the WD-1215-L & -R to the two F-1206D as shown in Figure 1.

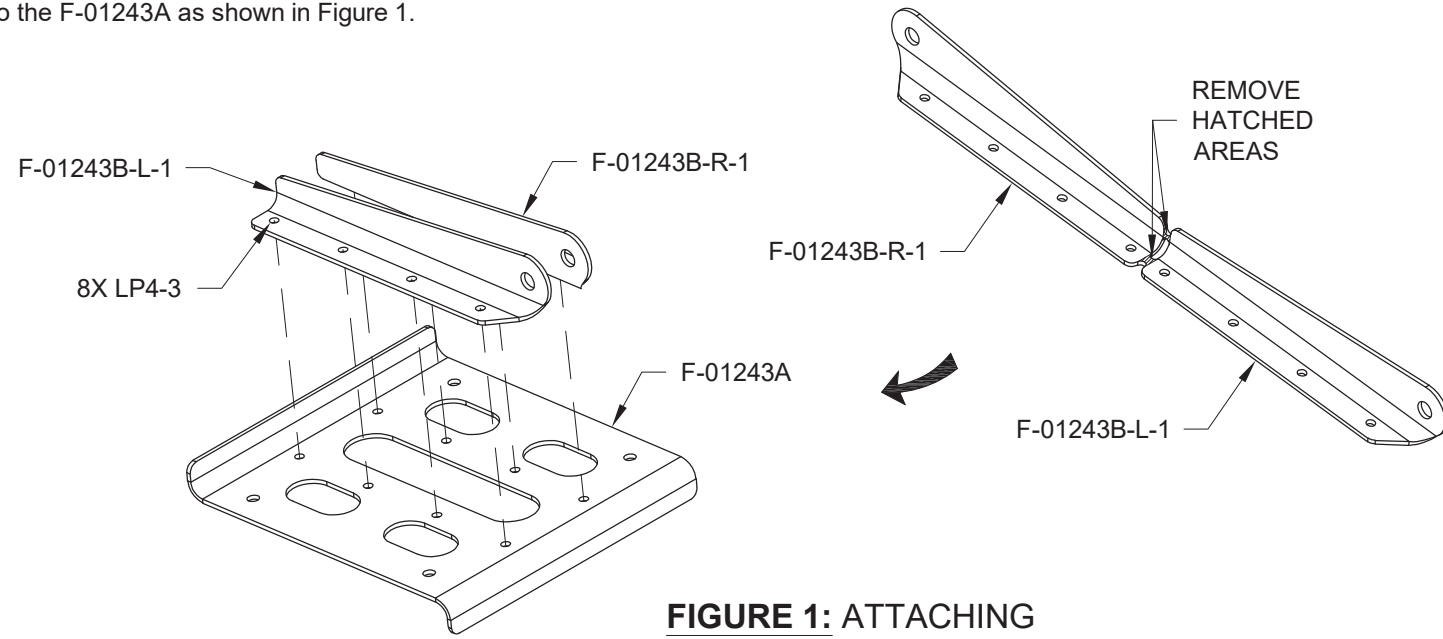
Step 2: Attach the aft end of each Flaperon Pushrod Assembly to the WD-1215-L & -R as shown.



**FIGURE 1: ATTACHING THE FLAPERON TORQUE ARMS**

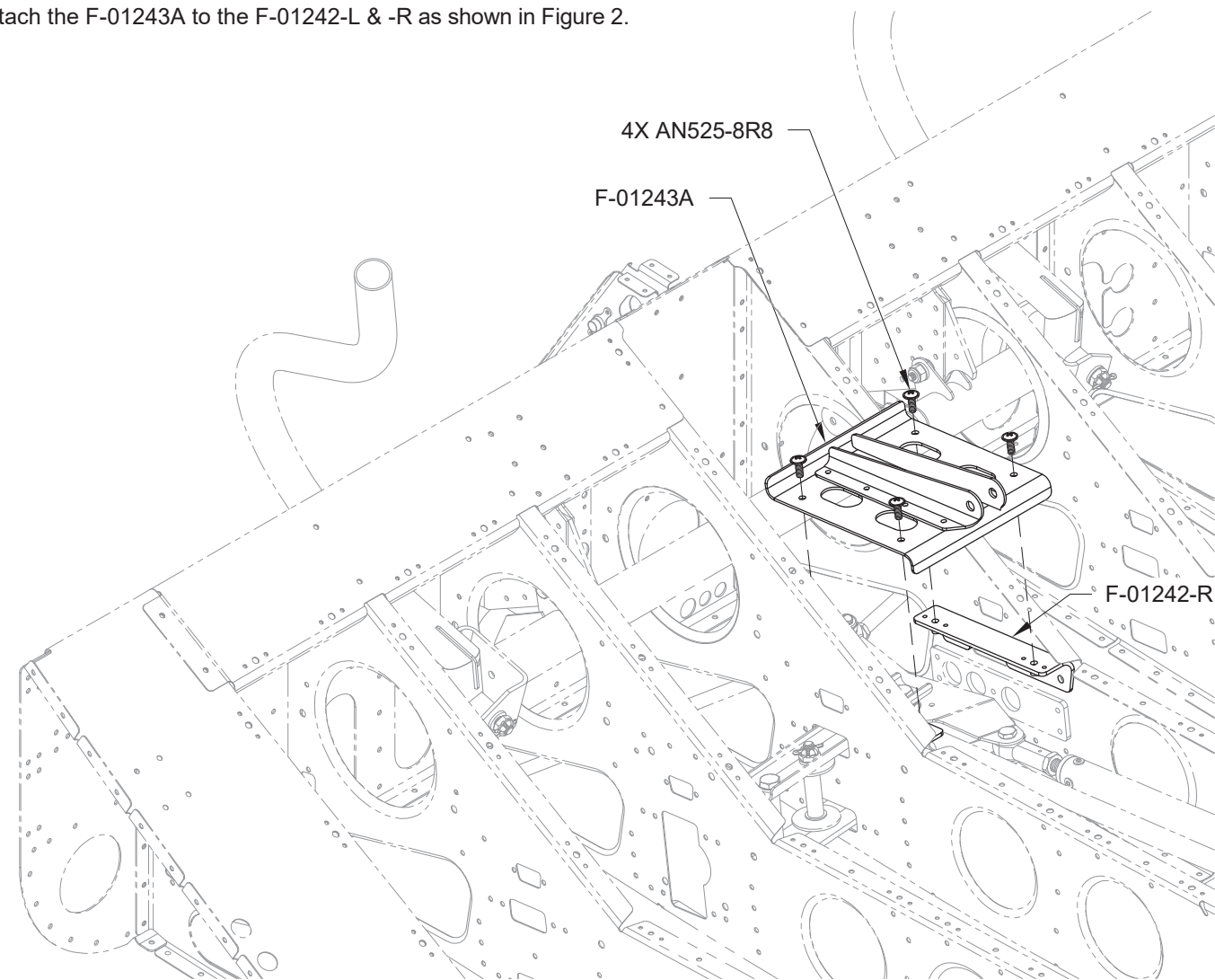


Step 1: Separate, then rivet the F-01243B-L-1 & -R-1 to the F-01243A as shown in Figure 1.



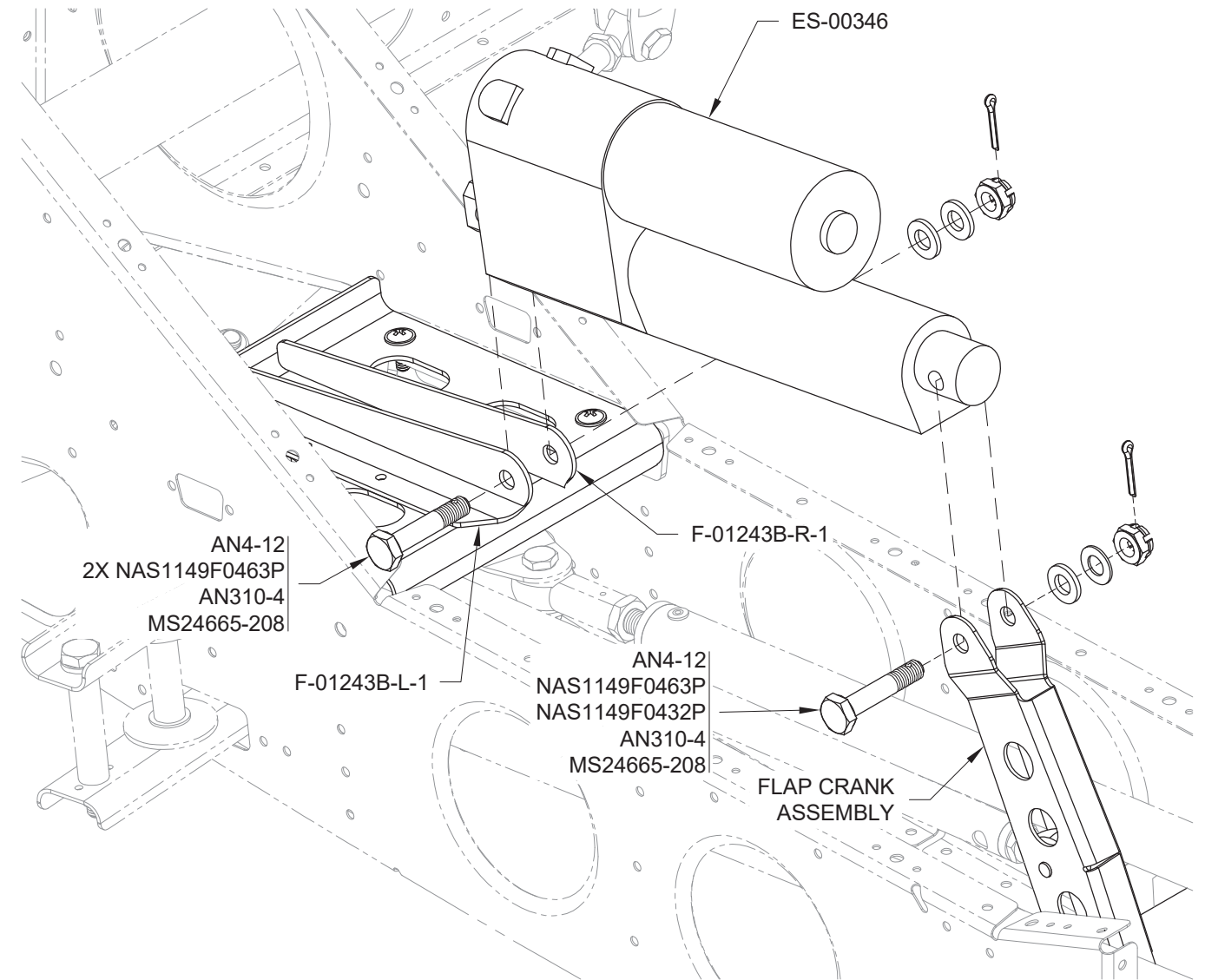
**FIGURE 1: ATTACHING THE FLAP MOTOR ATTACH BRACKETS**

Step 2: Attach the F-01243A to the F-01242-L & -R as shown in Figure 2.



**FIGURE 2: ATTACHING THE FLAP MOTOR CHANNEL BRACKET**

Step 3: Attach the ES-00346 to the F-01243B-L-1 & -R-1 and Flap Crank Assembly as shown in Figure 3. Refer to Section 5.20 regarding fasteners as pivot points.



**FIGURE 3: ATTACHING THE FLAP MOTOR**



**THIS PAGE INTENTIONALLY LEFT BLANK**