

SECTION 33: MISCELLANEA

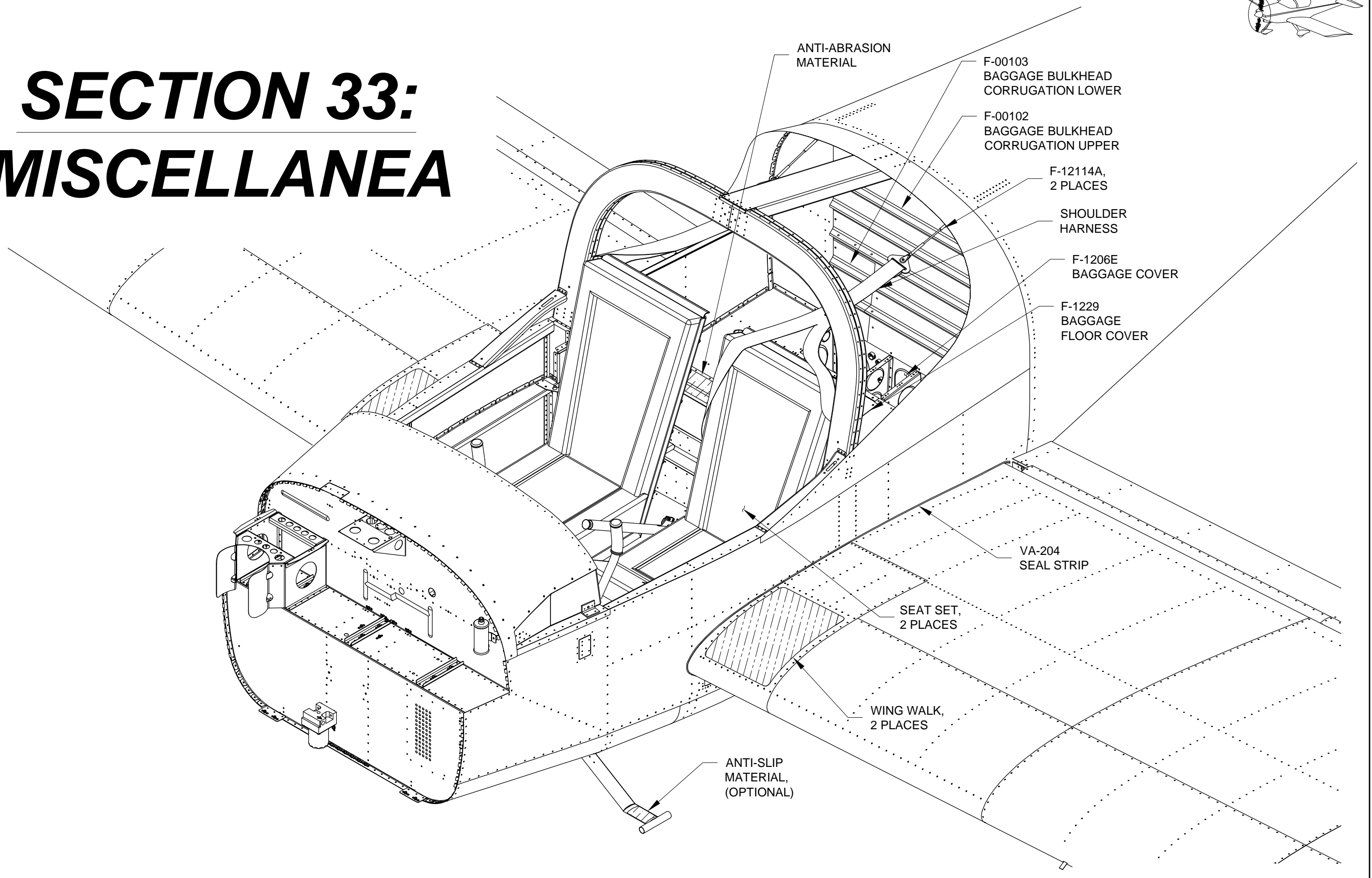



NOTE: If desired, the aircraft interior and interior cover panels should be primed and or painted before completing the steps in this section.

Step 1: Dimple the nutplate rivet holes in the F-1228 Seat Floor Cover and the nutplates as shown in Figure 1. Rivet the nutplates to the seat floor cover as shown in Figure 1.

Step 2: Remove the Detent Bracket Assembly and slip the F-1228 Seat Floor Cover over the WD-1213 Flap Handle as shown in Figure 1. Attach the seat floor cover to the F-1225-L & -R Seat Floors, then screw the Detent Bracket Assembly to the seat floor cover using the hardware called out in Figure 1.

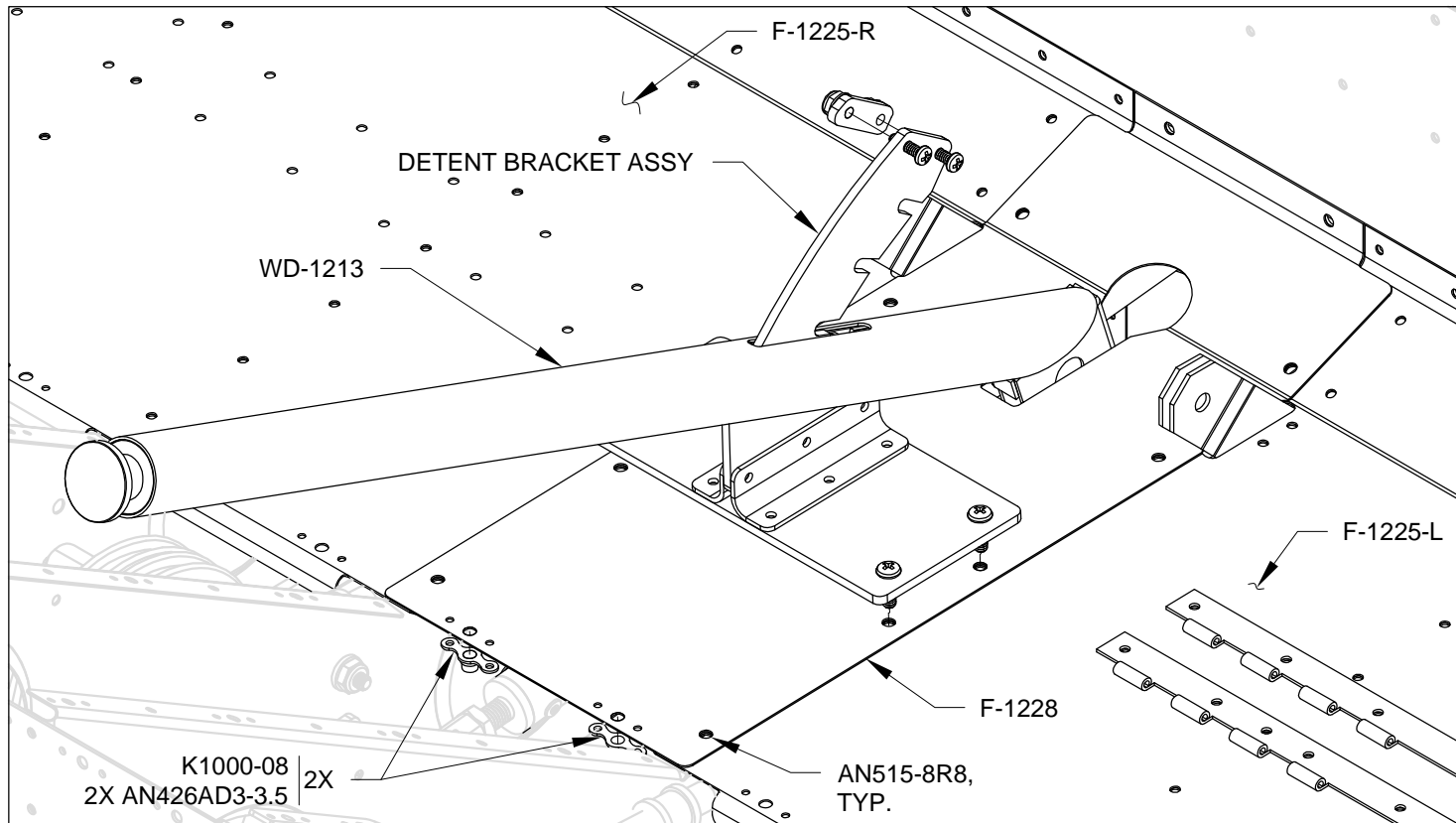

FIGURE 1: SEAT FLOOR COVER INSTALLATION (SOME PARTS NOT SHOWN FOR CLARITY)

NOTE: Two opposite belt sections (one male and one female) should be mounted at the center lug locations to prevent the belts from being used by the incorrect seat position. Take care when installing the lap belts that the belts will not be twisted when fastened together.

Step 3: Attach the end fitting of the lap belts to the F-1217C Seat Belt Attach Lugs using the hardware shown in Figure 2.

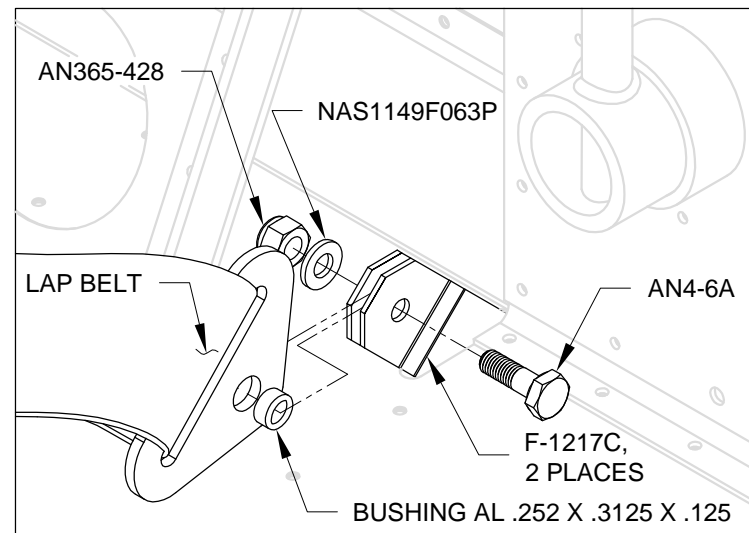

FIGURE 2: LAP BELT ATTACH

Step 4: Attach the end fitting of the crotch straps to the F-1267A and F-1267B Crotch Strap Lugs using the hardware called out in Figure 3.

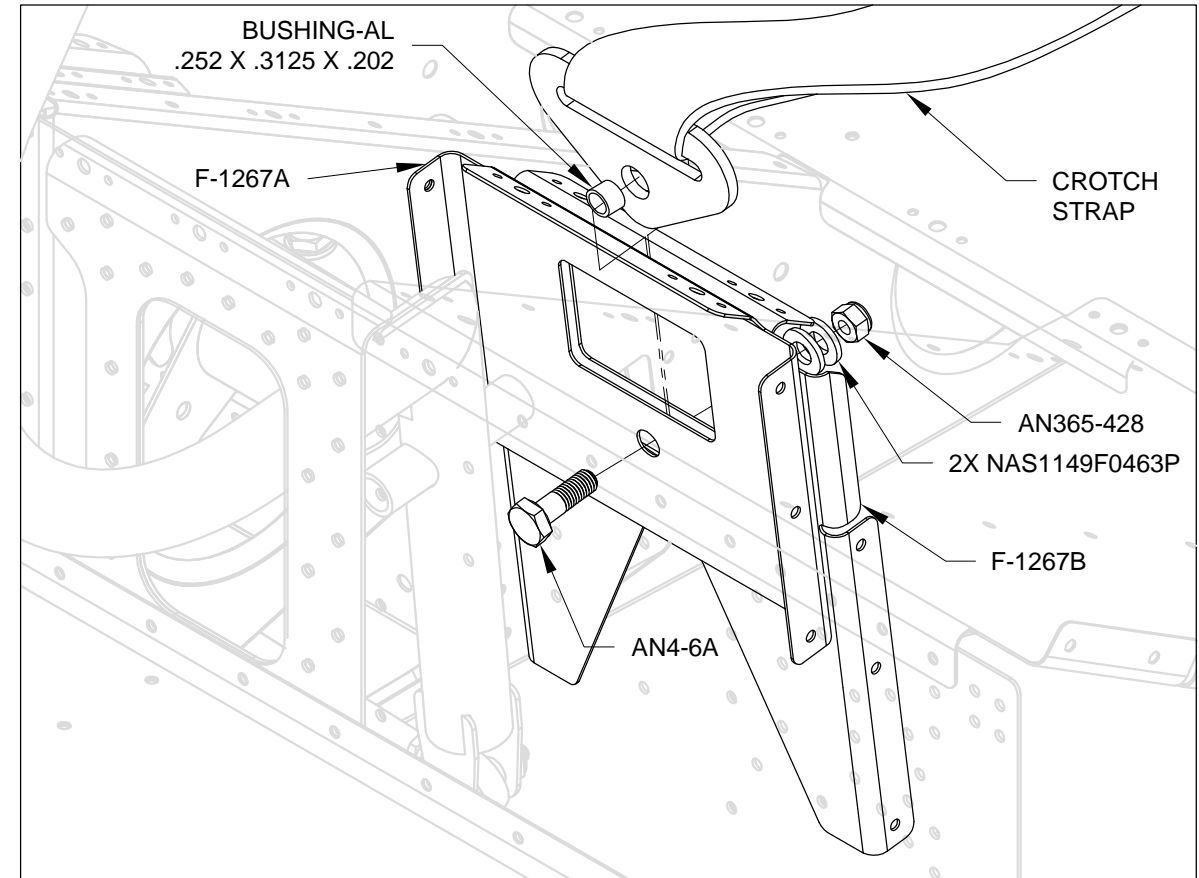

FIGURE 3: CROTCH STRAP INSTALLATION (SOME PARTS NOT SHOWN FOR CLARITY)

NOTE: If installing the Dual Display Optional Kit do not install the F-1214 Step Floor Cover at this time.

Step 5: Remove the VA-104-3 Knob and fasten the F-1227 Seat Ramp Cover and F-1214 Step Floor Cover in place using the hardware called out in Figure 4. Reattach the knob.

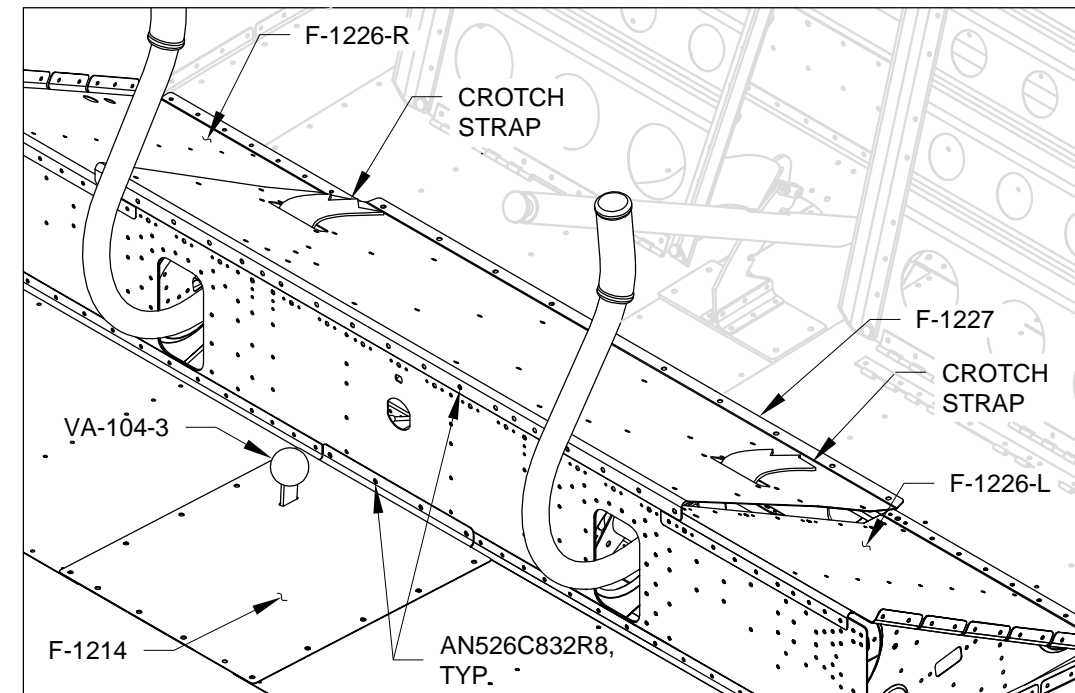

FIGURE 4: SEAT RAMP COVER INSTALLATION



Step 1: Attach one end of the F-12114 Shoulder Harness Cables to the F-1207E Shoulder Strap Lug using the hardware called-out in Figure 1. No bushings are needed at this end.

Step 2: Attach the other end of the F-12114 Shoulder Harness Cables to the Shoulder Harness as shown in Figure 1. The bushings will allow the end fittings to rotate freely.

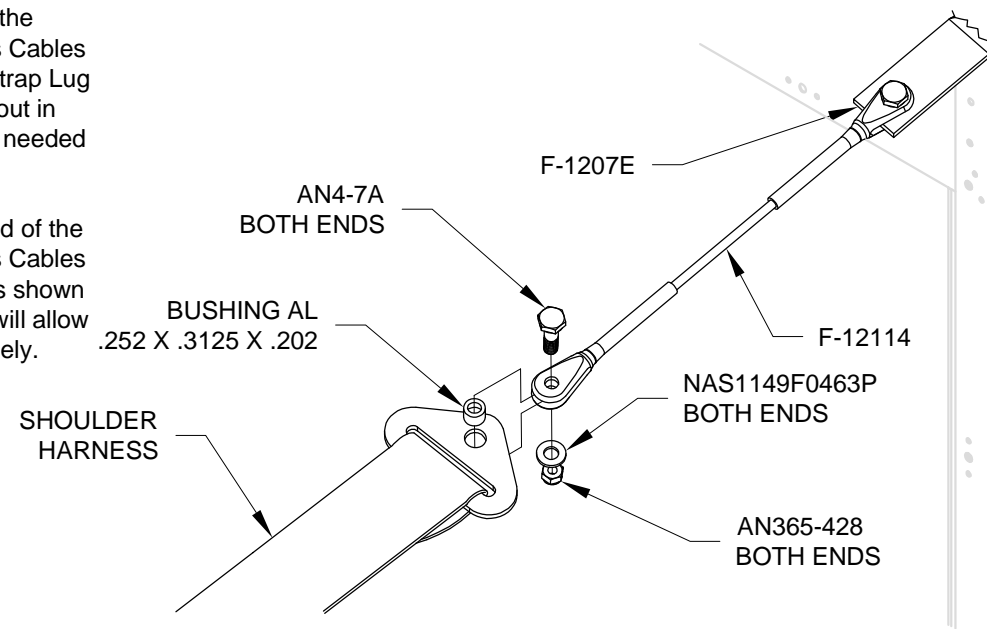

FIGURE 1: SHOULDER HARNESS ATTACH

Step 8: Align the common holes and edges of the F-00102 Baggage Bulkhead Corrugation Upper and F-00103 Baggage Bulkhead Corrugation Lower. See Figure 5.

Match-Drill #19 the holes indicated in Figure 5.

Step 9: Dimple all #40 holes and install nutplates to the aft face of the F-00103 Baggage Bulkhead Corrugation Lower. See Figure 4.

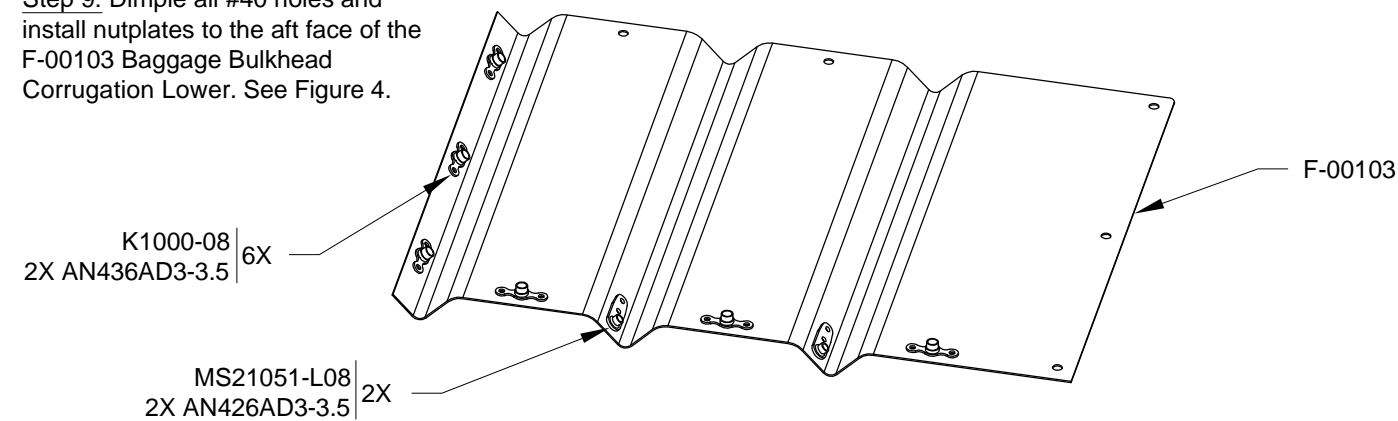

FIGURE 4: INSTALLING NUTPLATES (AFT FACE SHOWN)

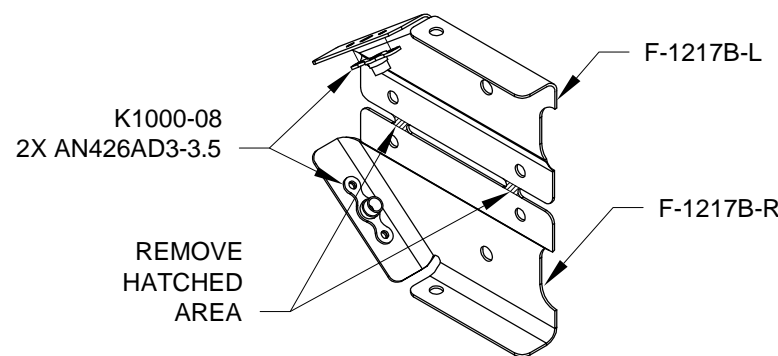

FIGURE 2: RUDDER PEDAL ACCESS COVERS

Step 3: Make the F-1217B-L and -R Rudder Pedal Access Covers by removing the hatched area from the F-1217B Rudder Pedal Access Cover as shown in Figure 2. Deburr.

Step 4: Dimple the nutplate rivet hole locations in the the F-1217B-L and -R Rudder Pedal Access Covers and in the nutplates. Rivet the nutplates to the rudder pedal access covers as shown in Figure 2.

Step 11: Install the F-00102 Baggage Bulkhead Corrugation Upper over the baggage bulkhead corrugation lower with screws to make the Baggage Bulkhead Corrugation Assembly. See Figure 5.

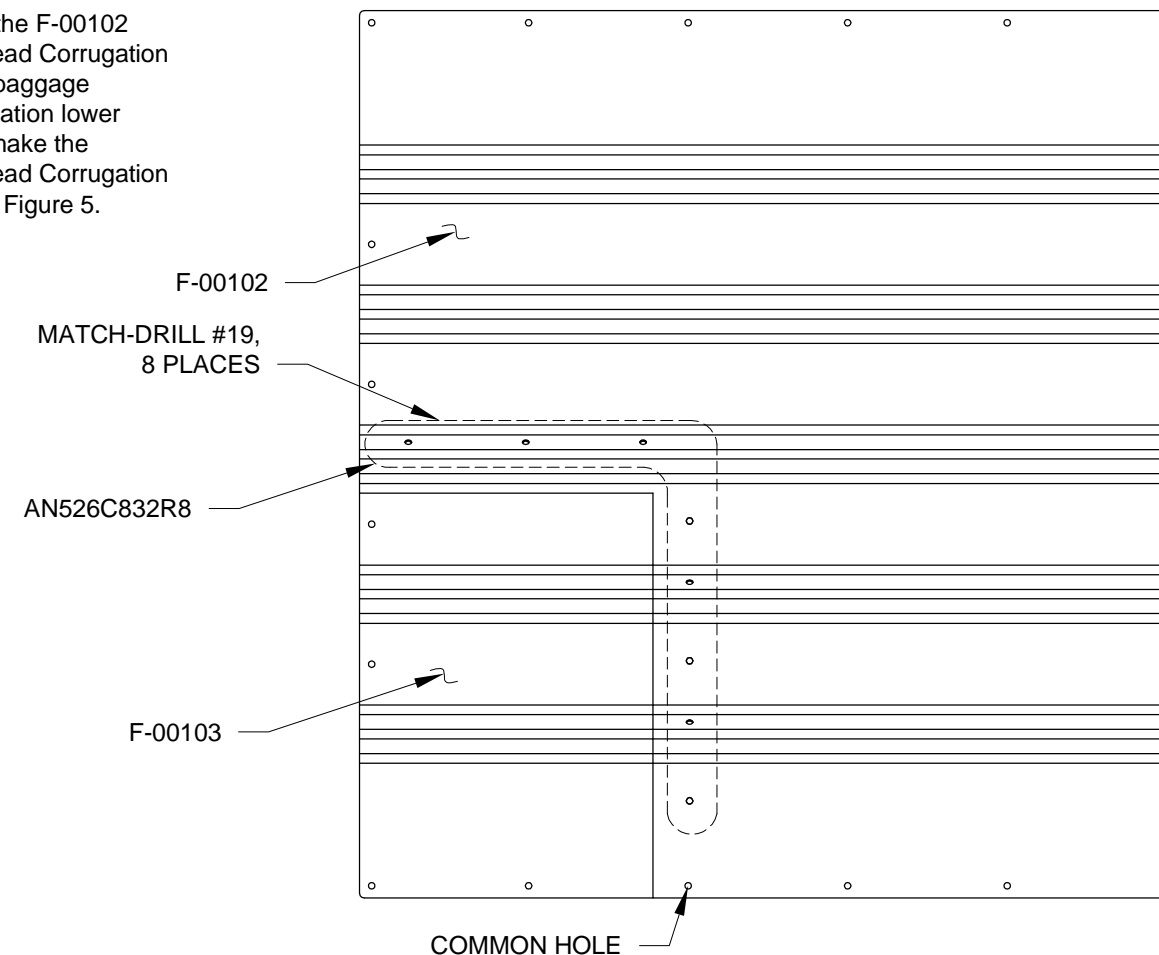

FIGURE 5: MATING THE BAGGAGE BULKHEAD CORRUGATIONS

Step 5: Install the F-1217B-L and -R Rudder Pedal Access Covers using the hardware called out in Figure 3.

Step 6: Trim the MS21266-1N Grommet to 2 13/32 inches and install on the F-1230 Tunnel Cover as shown in Figure 3.

NOTE: If installing the Dual Display Optional Kit do not install the 12 aft most screws in the F-1230 Tunnel Cover at this time.

Step 7: Install the F-1230 Tunnel Cover using the hardware called out in Figure 3.

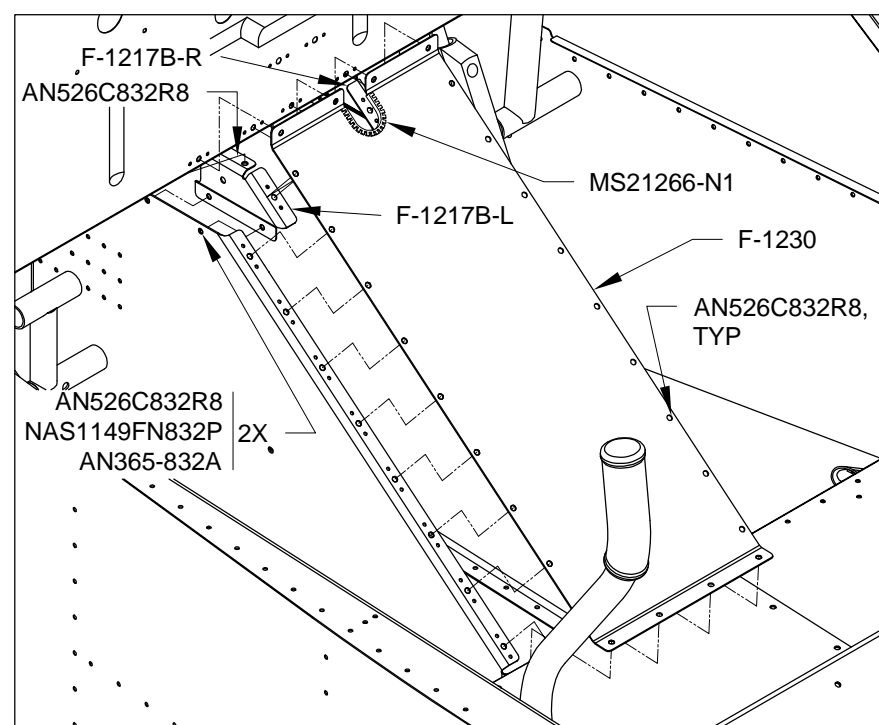
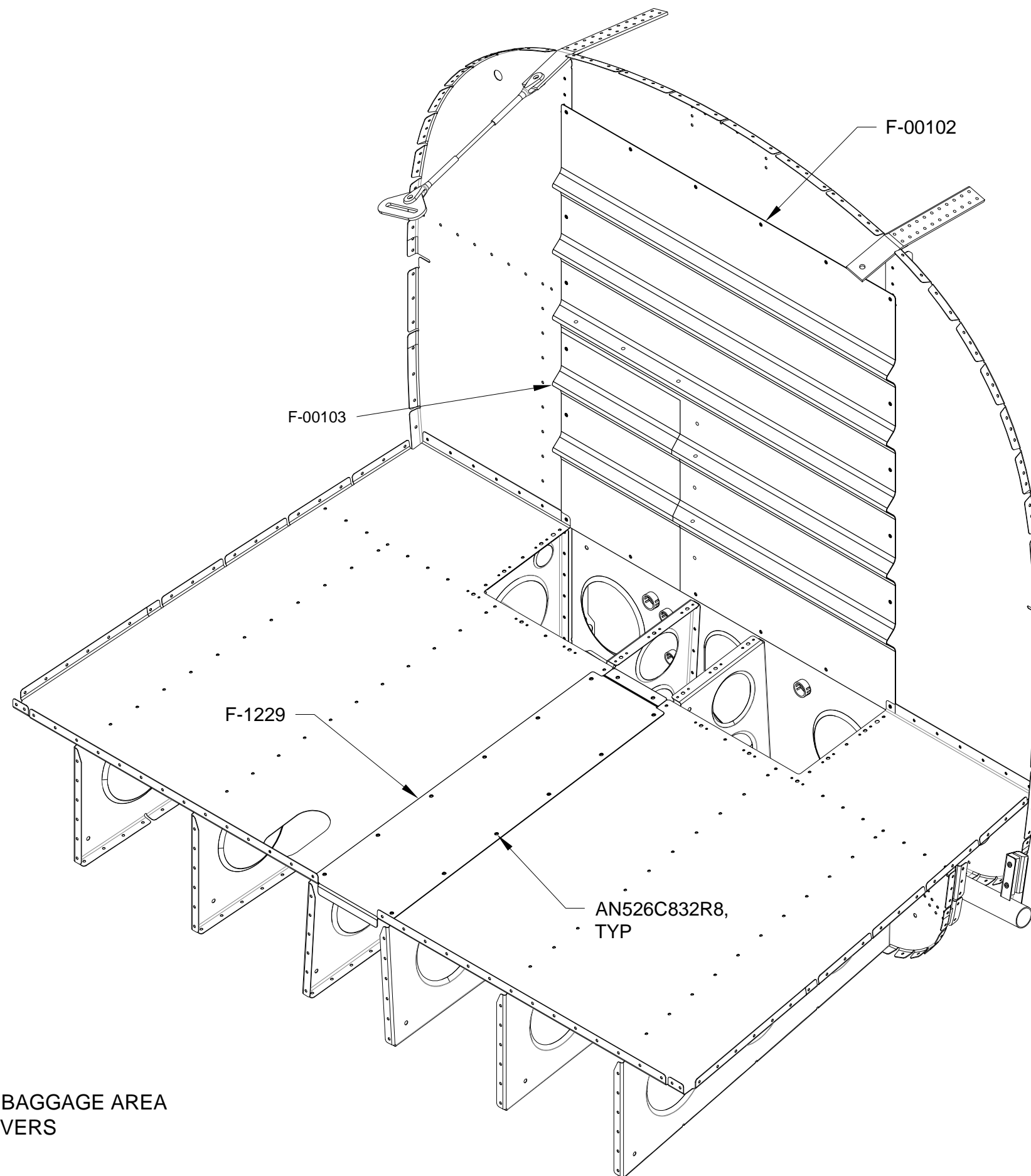

FIGURE 3: TUNNEL COVER INSTALLATION



Step 1: Install the F-1229
Baggage Floor Cover, and the
Baggage Bulkhead Corrugation
Assembly using the hardware
called out in Figure 1.



**FIGURE 1: INSTALLING BAGGAGE AREA
ACCESS COVERS**

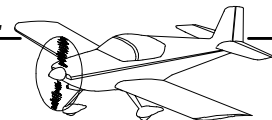

Step 1: Test fit the F-12119B Anti-abrasion Strip to the F-1205A Mid-Fuse Brace. The top and front surfaces of the mid-fuse brace are covered as shown in Figure 1. With an ultra-fine felt tip marker and a straight edge, make a line on the top of the mid-fuse brace forward of the aft edge as shown in Figure 1.

Step 2: To install the F-12119B Anti-abrasion Strip, clean and dry the mid-fuse brace surface. Fold the top half inch of the paper backing strip back and crease. Starting at one side apply the exposed adhesive side of the anti-abrasion strip to the top of the mid-fuse brace along the traced line. Remove the rest of the paper backing and press the anti-abrasion strip to the front of the mid-fuse brace.

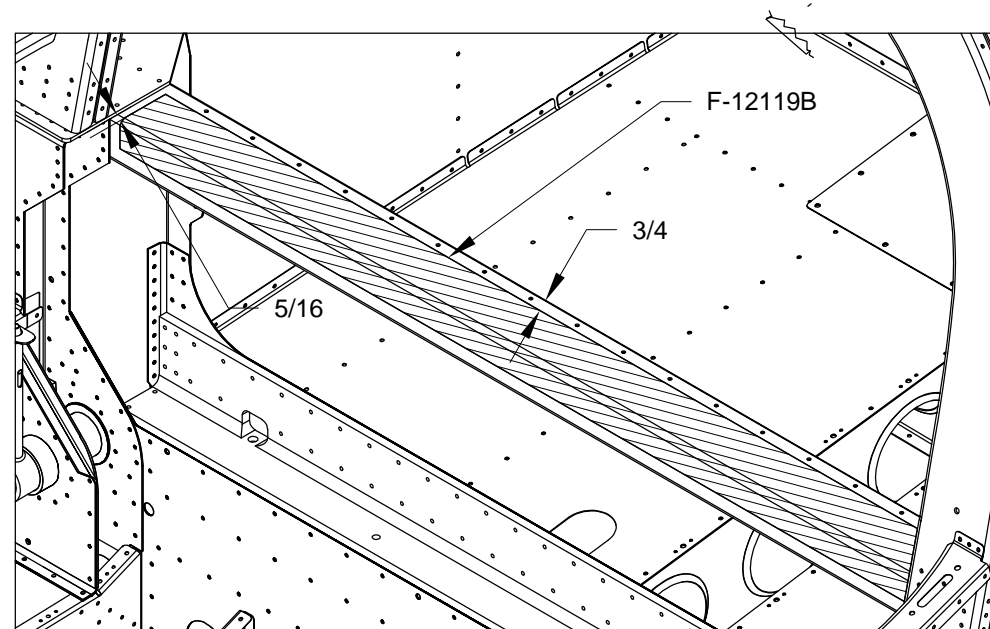

FIGURE 1: ANTI-ABRASION STRIP INSTALLATION

Step 3: Test fit the F-12119A Non-Skid Step Floors to the F-1213-L and -R Step Floors. Position as shown in Figure 2. The forward edge of the non-skid step floors shall be parallel to the forward edge of the step floors. Adhere the non-skid step floors to the clean and dry step floors as shown in Figure 2.

Step 4: Position the Seat Wedge, Seat Bottom, and Seat Back as shown in Figure 2. The Crotch Strap should be pulled through a slot in the seat bottom as shown in Figure 2.

The seat back has a Velcro attach strip sewn onto a flap at the top of the seat. The free half of the Velcro strip has an adhesive back and may be applied to the F-1237B Seat Back Angle to hold the upholstered seat cushion in place. Adding Pliobond adhesive to the Velcro strip before installation is recommended to ensure a good hold.

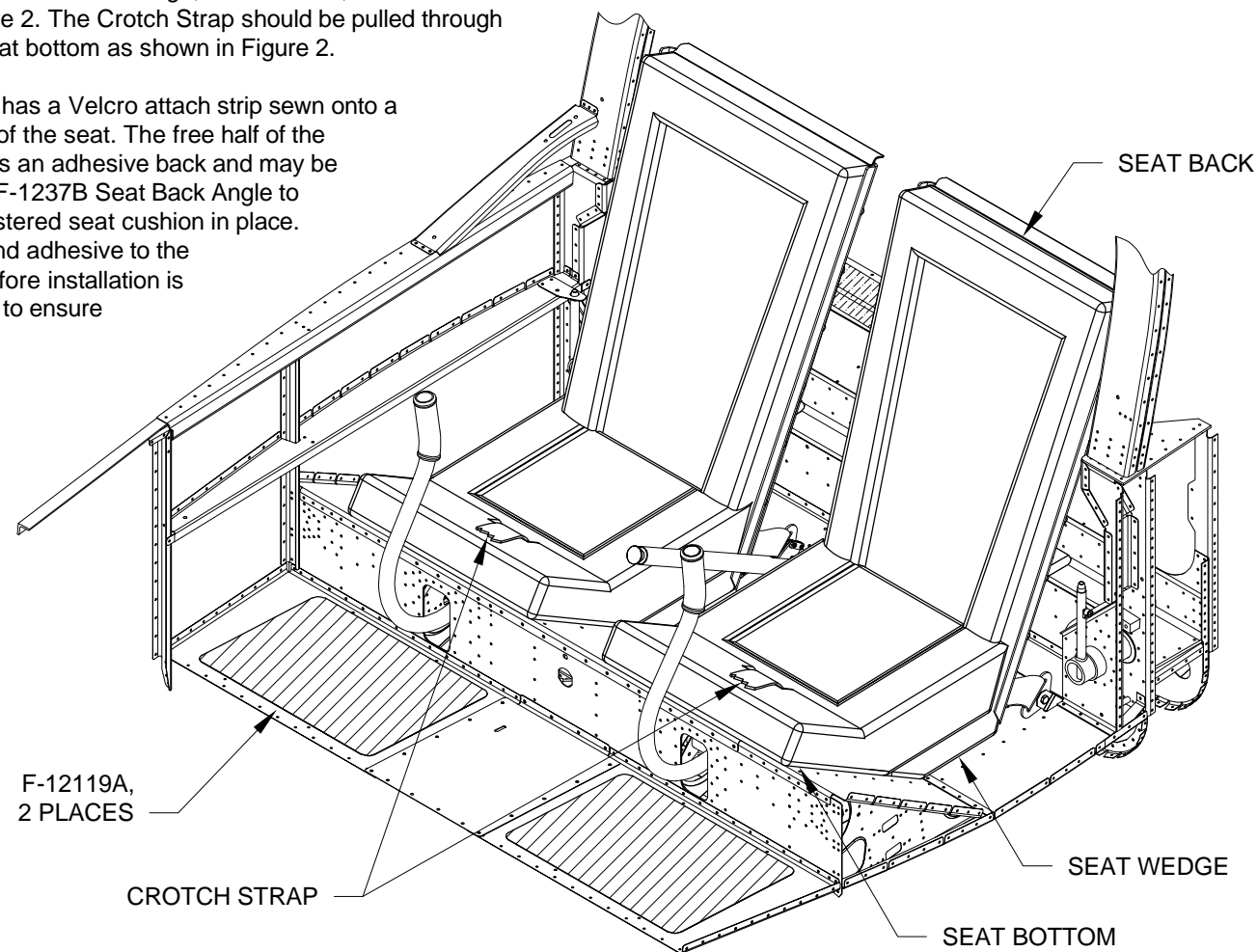

FIGURE 2: SEAT INSTALLATION

NOTE: If the wings have not been painted, delay installation of the F-12119C Wing Walk until after painting. Anti-slip material for the steps is not included in the kit, but is available from a number of sources and is highly recommended. See manufacturer's instructions for installation details.

Step 5: Apply F-12119C Wing Walk to the wing surface as shown in Figure 3.

Step 6: Apply anti-slip material (approximately 2 inches X 3 inches is needed) to the steps as shown in Figure 3.

NOTE: Practice following the outlined curve with masking tape before installing the VA-204 Seal Strip. Once the seal strip is installed it is very difficult to remove. Installation of VA-204 can be delayed until after paint, but the gap must be sealed prior to any flight.

Step 7: With the wings installed, take a ultra-fine felt tip marker and, holding the pen body flat against the wing skin, outline each wing, top and bottom, on the side of the fuselage. See Figure 3 Section A-A. To avoid a bumpy outline on the fuselage, mark only between where the rivets on the wing are. This should produce an outline approximately 1/4 inch outside of where the wing meets the fuselage. Make a mark at the top and bottom skins trailing edges to show where the seal starts and ends. Remove the wings.

Step 8: Align the beveled edge of the VA-204 Seal Strip with the outline traced on the side of the fuselage so that it just covers the line as shown in Figure 3 Section A-A. Care should be taken to make a smooth curve with the seal strip. The seal strip should not be overly stretched as it is installed.

Step 9: The VA-204 Seal Strips go over a couple of screw heads and the F-1270B Fuselage Access Panels. After installation the seal strips can be carefully trimmed around the screw heads using a sharp razor blade or knife. Make a slit where the seal strips cross the access panels so that they may be removed.

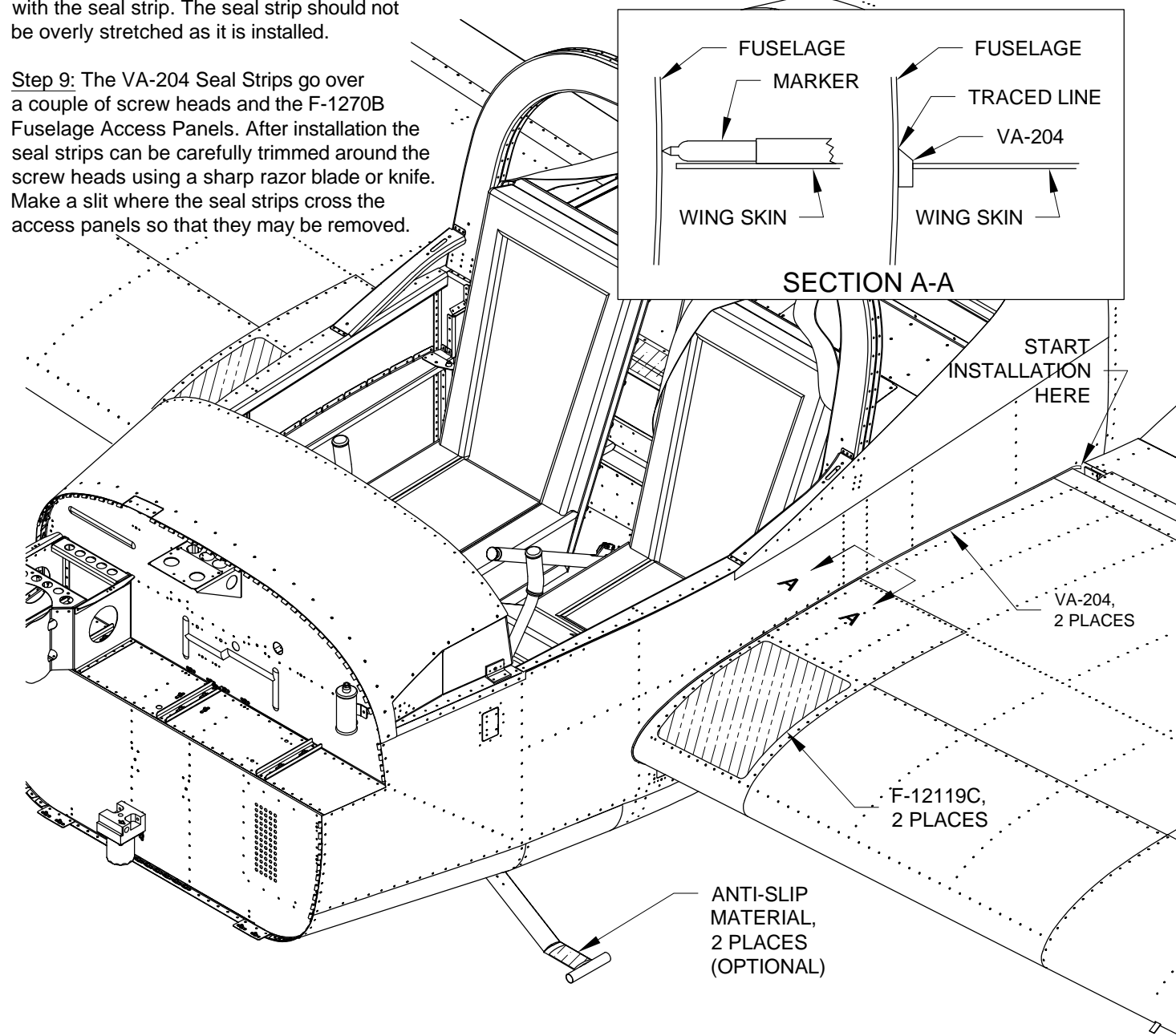

FIGURE 3: WING WALK AND STEPS



THIS PAGE INTENTIONALLY LEFT BLANK