

CIRCUIT LETTER FUNCTION	
LETTER	CIRCUITS
C	CONTROL SURFACE
D	INSTRUMENT
E	ENGINE INSTRUMENT
F	FLIGHT INSTRUMENTS
H	HEATING VENTILATING
J	IGNITION
K	ENGINE CONTROL
L	LIGHTING
P	POWER CONTROL
Q	FUEL
R	RADIO
RZ	HEADPHONE
T	SPECIAL ELECTRONIC
TC	RADIO CONTROL
TD	AIRBORNE ANNOUNCING
TP	BEACON
TQ	TRANSMITTER RECEIVER
W	WARNING EMERGENCY

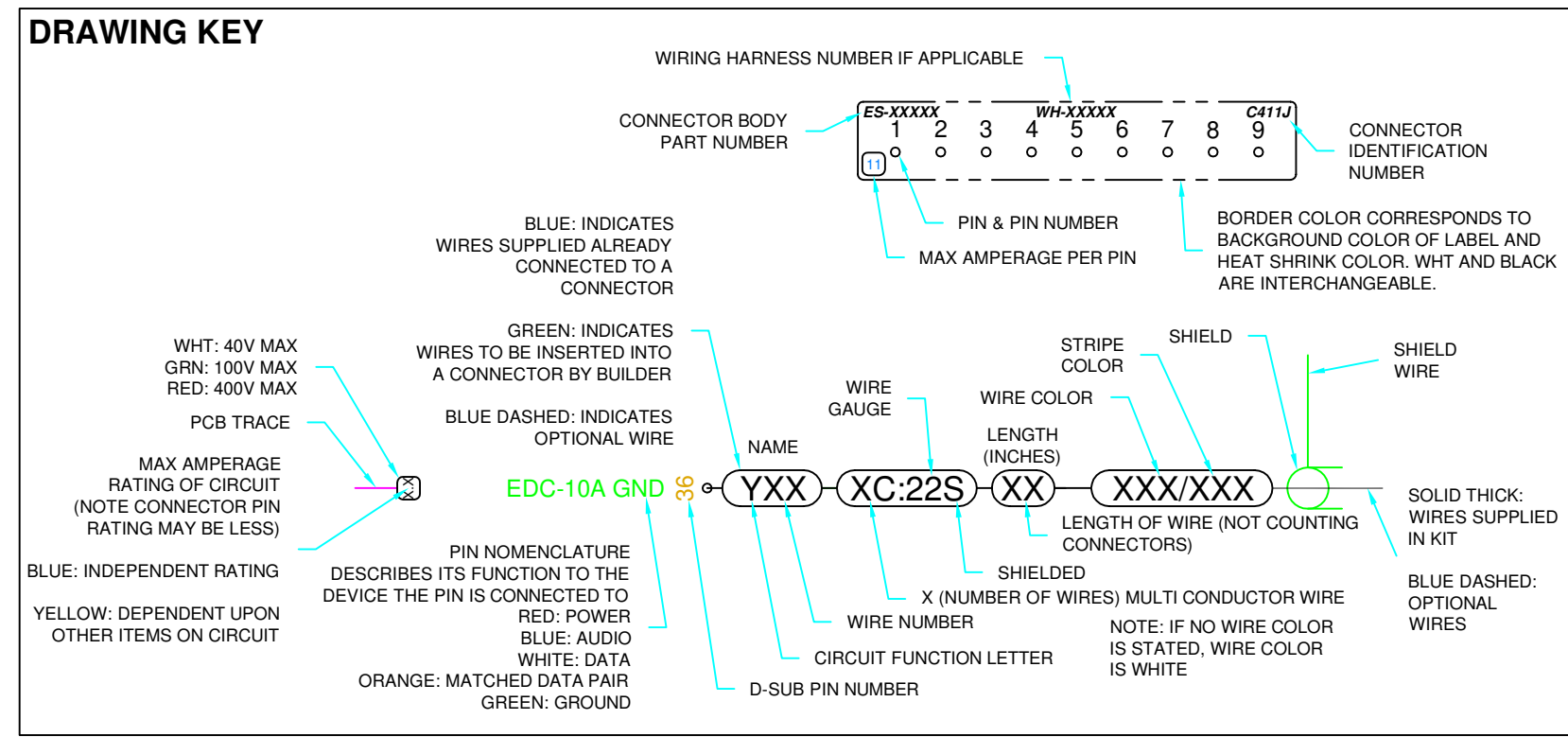

REV	DESCRIPTION	DATE	APPROVAL
R0	APPROVED FOR PROD.	10/29/18	TDM
R1	ADDED TEST PROC AND WING WIRES	11/06/18	TDM
R2	ADDED TY96 COM RADIO	12/01/18	TDM
R3	GTR200 UPDT TO 200B, ADDED PTT, AP-DISC C7116 CHANGED TO C7257 GEN B TERM. CHANGED TO ES 35110	01/29/19	TDM
R4	-ROLL SERVO GROUND WIRE EXTENDED -RING TERMINAL UPSIZED FOR EFIS SWITCH & BACKUP BATT -L7258 (WHT) WAS L7019 (DUPLICATE #)	05/02/19	TDM
R5	E6023 WIRES CROSSED AT HIC TO NEGATE AV-60009 PCB ERROR, WHT NOW LO & WHT/BLU NOW HI, ADDED OPTIONAL CO DETECTOR, TY96 CONNECTOR NOW ES-00060, ADDED NOTE FOR TY96 UNUSED PINS, ADDED MISSING WHT/BLU R7183 WIRE TO GDU 460 (PFD) PIN 18, ON F6262 & Q6300 ES 31880 WAS ES 36152, Q6300 27 WAS 40, ADDED CABIN LIGHT DIMMER, DELETE L6029, ALL WIRES TO GMC 307 EXTENDED 4 INCHES, NUMEROUS CORRECTIONS	11/08/19	BPN
R6	CHANGED CO DETECTOR WIRING, ADDED WH-00144	01/06/20	BPN

**ELECTRICAL SYSTEM BENCH TEST PROCEDURE**

**Avionics Group**

1. Check PFD & MFD Power On
2. SkyView Check PFD and MFD recognize a USB stick
3. Install latest software and settings per the readme files (applicable portions) on the Van's Web Site
  - a. Setup X Pndr Hex Code
  - b. Setup AP servos if installed
4. Check PFD & MFD recognize all LRU's
5. Check X pndr will transmit.
6. Check COM turns on.
7. Check PFD recognizes COM, and can push frequencies to COM radio
8. Check Backup Battery Function PFD
9. If installed check AP Control Head function (knobs function for SkyView as well)

**Audio Group**

1. Configure COM radio in accordance with "GTR 200B Internal Presets" or "Trig TY96 Internal Presets"
2. Check Pilot Headset Jack
3. Check Pilot Mic Jack for Xmit
4. Check Co-Pilot Headset Jack
5. Check Co-Pilot Mic Jack for Xmit
6. If installed check XM music output to headset.

**Cockpit Group**

NOTE: If customer has selected the pre-wired stick option then use their control sticks

1. Check Pilot TX Button
2. Check Pilot Trim Buttons (Both Directions)
  - a. Verify proper trim direction movement on screen indicator and servo with input
3. Check Co-Pilot TX Button

4. Check Co-Pilot Trim Buttons (Both Directions)
  - a. Verify proper trim direction movement on screen indicator and servo with input

5. Check function of AP disconnect switch near throttle.
6. Check Pilot AP Disconnect Switch
7. Check Co-Pilot AP Disconnect Switch
8. Check Pilot COM Freq Swap
9. Check Co-Pilot Freq Swap
10. Check Dimmer (Note PCB portion will be checked during AV-60000 Check)
  - a. Turn on all switches. Check that all lighted switches lights turn on and dim. (Ignore wires going to cabin light.)
11. Check canopy latch switch
12. Check flap motor function both directions
13. Check for power output at USB connectors / Power Outlet

**Wing Group**

1. Check Stall Warning
2. Check NAV/Strobe Lights
3. Check Landing Lights (Both if applicable)
4. Check Wig Wag Function

**iS Engine Group**

1. Check Master Relay Switch grounds out wire going to master relay
2. Check Key switch connects HIC connector start pins
3. Check spar pin light comes on when spar pin switches are not grounded.
4. Check emergency switch provides power to Power X3 connector Pin 3
5. Check Emergency Li Bat Warn Wire turns on warning in EFIS when grounded. (NOTE Check this error)
6. Check fuel pump A and B switches for function

**ELECTRICAL SYSTEM NOTES**

- USE M22759#16 OR M27500 TEUFZEL AIRCRAFT WIRE. CONTACT VAN'S ABOUT USING OTHER EQUIV.
- USE MIL-I-23053 HEATSHRINK. CONTACT VAN'S ABOUT USING OTHER EQUIV.
- LABEL THE FLYING LEAD OF EACH WIRE WITH THE TRUNCATED NOMENCLATURE AND WIRE NUMBER.
- CONNECT ALL 20-24 AWG WIRES TO D-SUBS USING ES-SA-1017 SOCKETS OR ES-SA-1018 PINS. PERMISSIBLE TO STRIP 18 AWG WIRE TO FIT ES-SA01017 SOCKETS OR ES-SA-1018 PINS. ALL CRIMPS TO BE MADE PER MIL-C-22520F (1.2.2) USING A TYPE 1 TOOL.
- USE ONLY NOR-COMP BACKSHELLS ON D-SUB CONNECTORS (WITH THE EXCEPTION OF 50-PIN CONNECTORS)
- HARNESS MUST BE TESTED WITH ALL AVIONICS IN ACCORDANCE WITH THE "ELECTRICAL SYSTEM BENCH TEST PROCEDURE". RESULTS ARE TO BE SUPPLIED TO VAN'S FOR EACH HARNESS.
- CRIMPED MOLEX, TYCO, AND AMP TERMINALS ARE TO BE CRIMPED WITH THE MANUFACTURER'S RECOMMENDED CRIMPING TOOL.
- CRIMPED TERMINALS ARE TO BE INDIVIDUALLY PULL TESTED.
- DO NOT COVER WIRES WITH WIRE NET.
- HARNESSES ARE TO BE BUNDLED WITH LACING CHORD, WITH THE EXCEPTION OF BLUE TIE-WRAPS USED AT BULKHEAD STATIONS.
- ALL 3 CONDUCTOR JACKETED NON-SHIELDED WIRE MAY BE REPLACED WITH TWISTED WIRES OF THE SAME AWG SIZE AND THE SAME WIRE COLOR.
- ADJUST SOLDER SPLICE / RING TERMINAL SIZE AS REQUIRED TO ACCOMMODATE DESIRED WIRE GAUGE(S). MAINTAIN RING TERMINAL STUD/TAB SIZE.

**GTR 200B INTERNAL PRESETS**

**"MENU" BUTTON OPTIONS**

- MUSIC VOL 75%
- ICS VOL 80%
- ICS SOLCH AUTO
- COM MUTE ON
- COM MUTE ICS OFF
- ICS MUTE MUSIC OFF
- MUTE LEVEL FULL
- COM 3D ON
- ICS 3D ON
- COCKPIT NOISE NORMAL
- MUSIC BASE BOOST OFF
- MUSIC EQ OFF
- KEY BEEP VOL 50%
- CONTRAST +0

**INTERNAL MENU SETTINGS**

- SIDETONE 05
- MIC GAIN 05
- RF SOLCH 00
- MON SWAP ON
- INTERCOM ENABLE YES
- RECIEVE OUT GAIN 100%
- AUX 1 SOLCH 30%
- AUX 1 VOL 50%
- AUX 1 MUTE NO
- AUX 2 SOLCH 30%
- AUX 2 VOL 50%
- AUX 2 MUTE NO
- PILOT RT NO

**SOFTKEY SETUP**

- 1 USER LISTS
- 2 TUNE EMERGENCY

**DISCRETE SETUP**

- 1 FREQ SWAP
- 2 DISABLED

LIGHTING SOURCE 14V

**GTR 200 PRESET NOTES:**

- ALL SETTINGS NOT DEFINED BY THIS DRAWING ARE ACCEPTABLE AS CONFIGURED FROM MANUFACTURER.
- THE ABOVE SETTINGS CORRESPOND TO SOFTWARE SYS 2.60.

**TRIG TY96 INTERNAL PRESETS**

- INTERCOM VOLUME:
- AUX IN VOLUME:
- MUSIC IN VOLUME:
- SIDETONE VOLUME:
- INTERCOM SOLCH:
- MIC 1 GAIN:
- MIC 2 GAIN:
- RADIO SOLCH:

TY96 PRESET NOTES:  
 -SET FREQUENCY STEP SIZE APPROPRIATE FOR REGION.  
 - ALL SETTINGS NOT DEFINED BY THIS DRAWING ARE ACCEPTABLE AS CONFIGURED FROM MANUFACTURER.

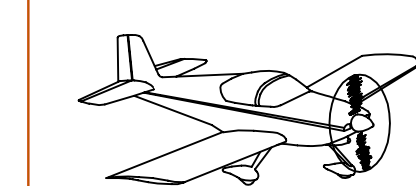

VAN'S AIRCRAFT, INC. 14401 NE KEIL RD. NE AURORA, OR 97002 USA

**ROTAX 912iS G3X ELECTRICAL SYSTEM**

DATE DRAWN: 06/11/18

DRAWN BY: T. DE MAN  
 TOLERANCES: NONE  
 (UNLESS OTHERWISE SPECIFIED)

UNITS: INCHES	WH-00134
SCALE: NONE	PAGE: 1 OF 11

PATH:FILENAME: Q:\RV-12\System iS\Electrical System iS\Electrical System 912iS G3X (WH-00134).DWG C-SIZE ORIGINAL

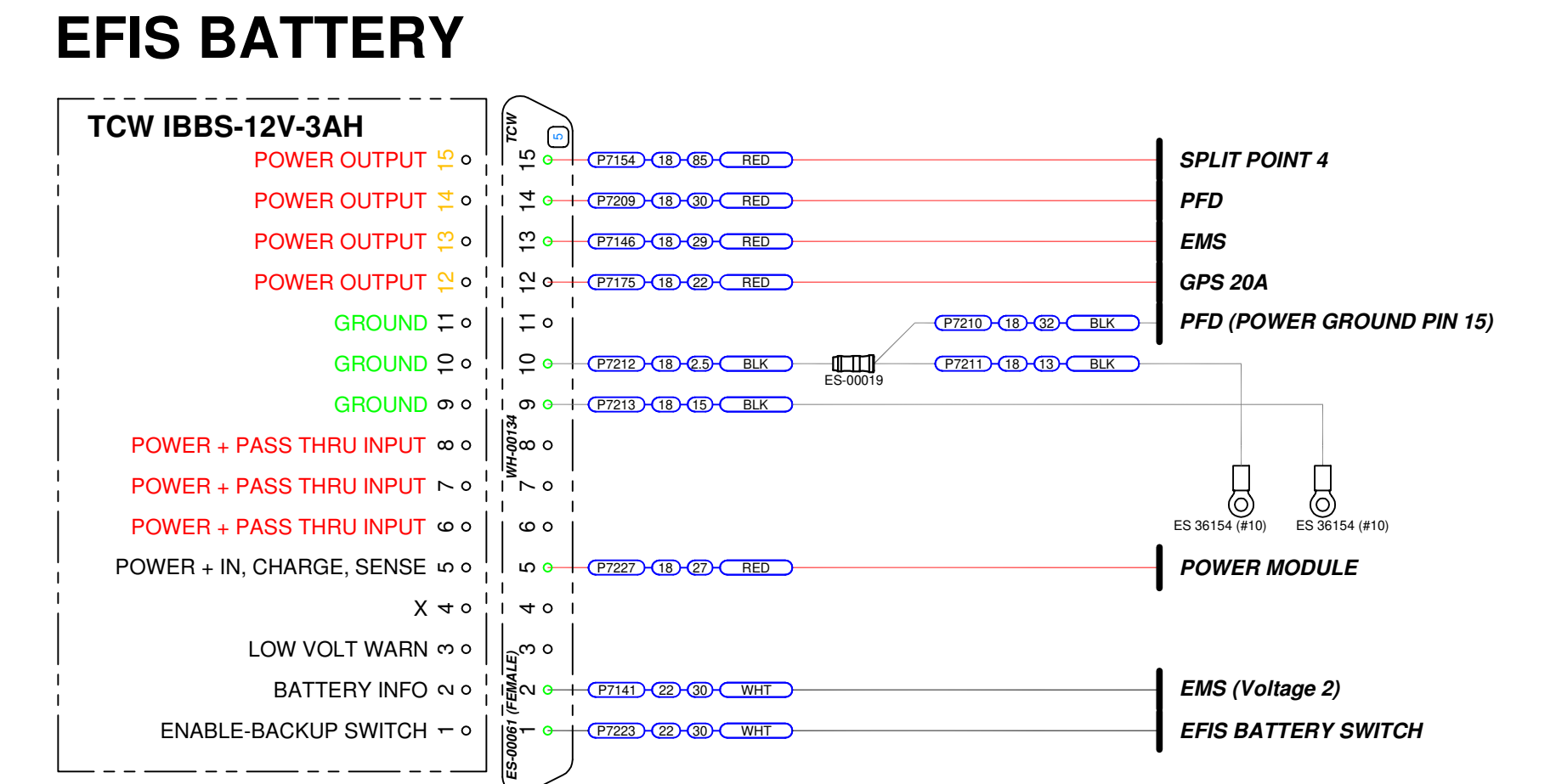
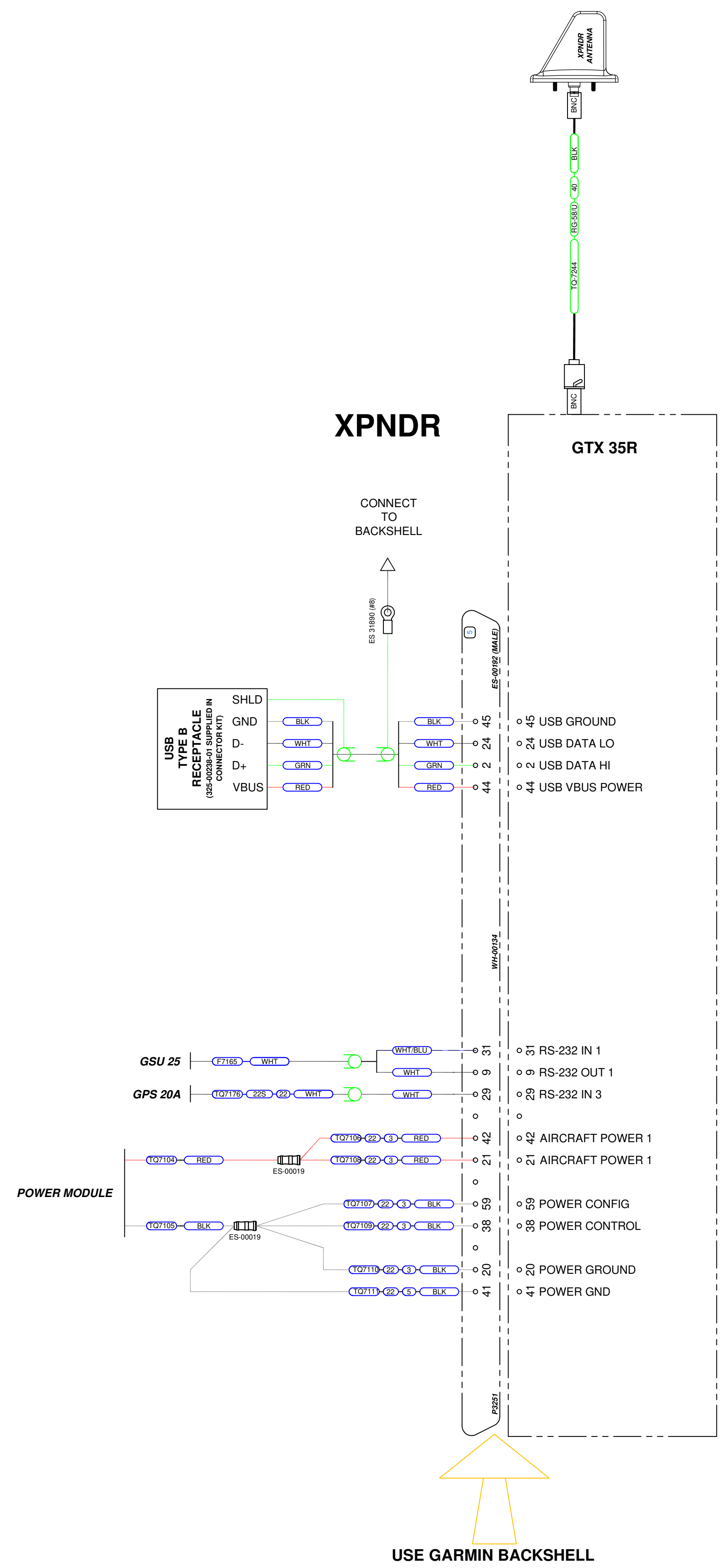
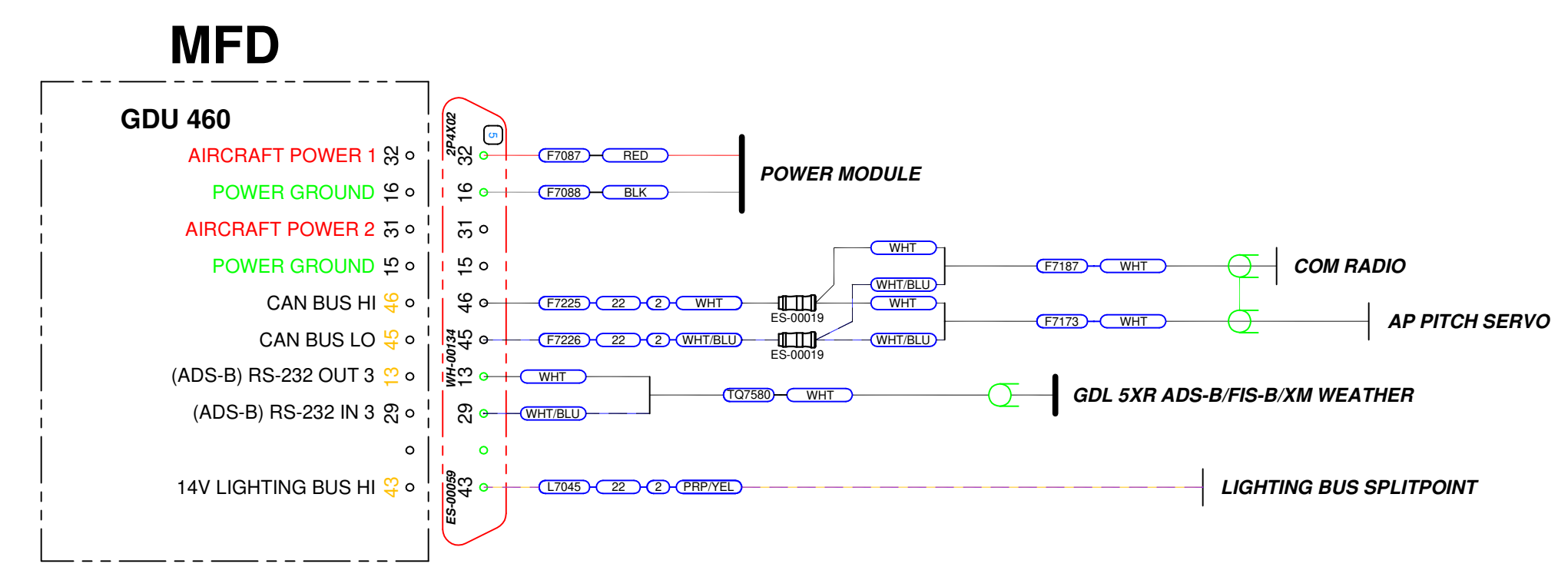
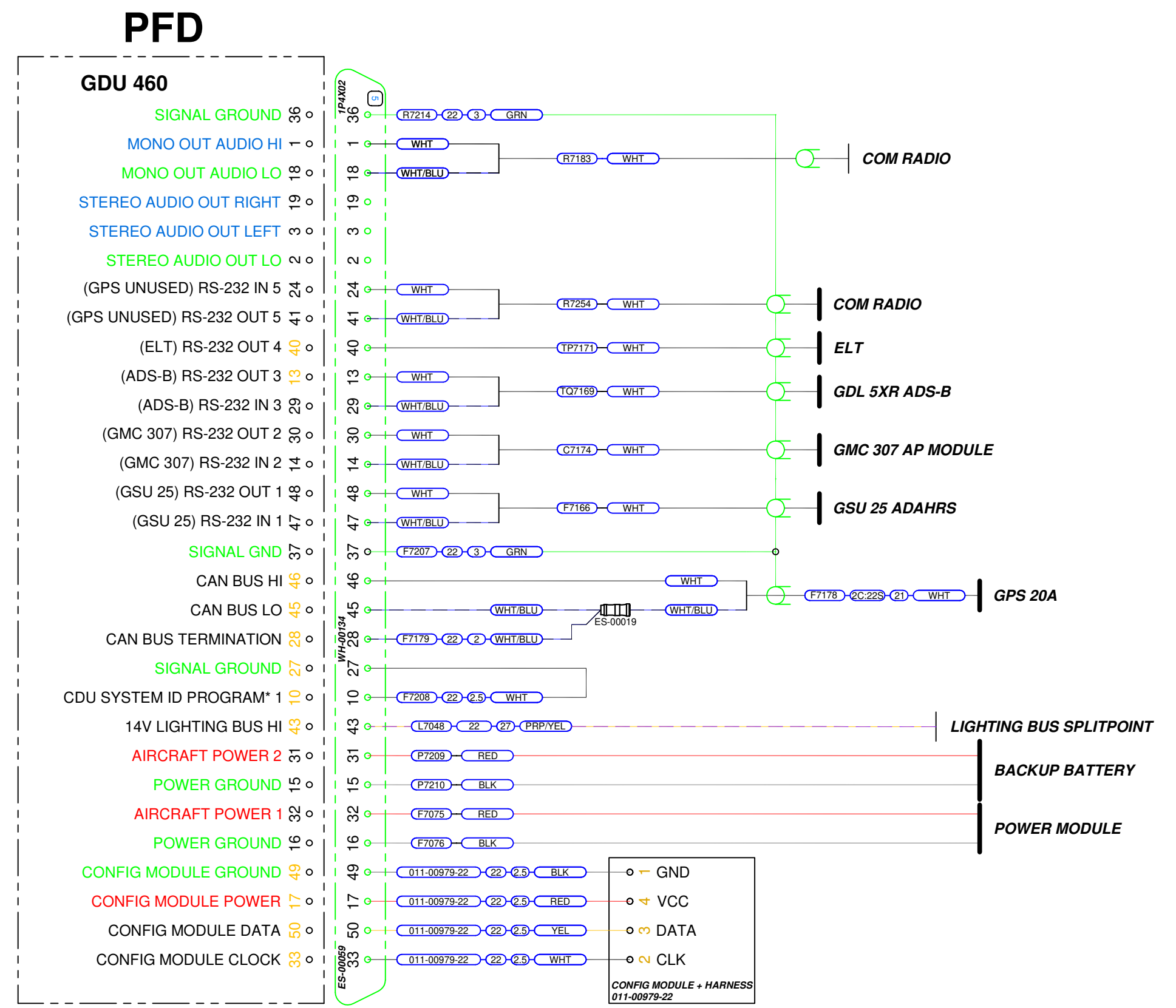

### PILOT STICK GRIP

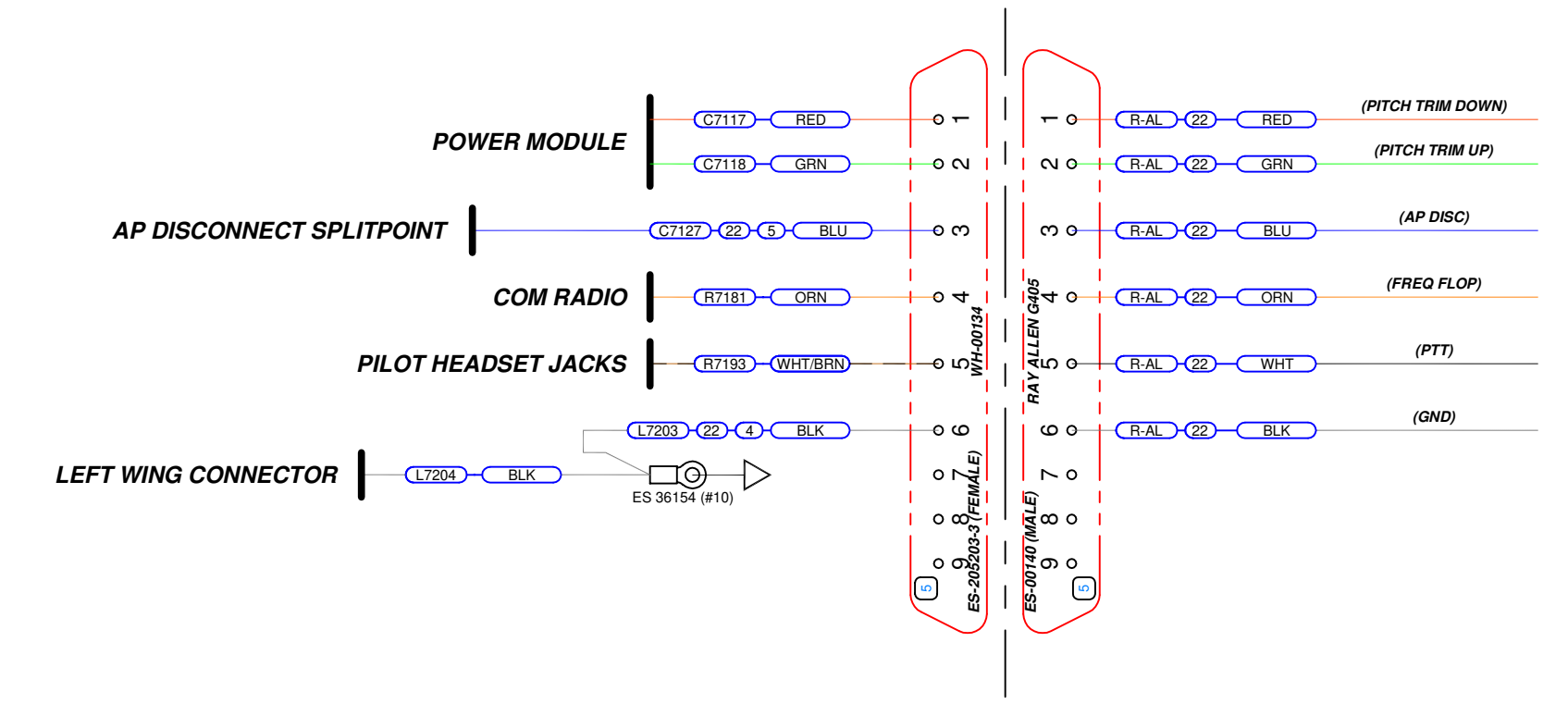

### CO-PILOT STICK GRIP

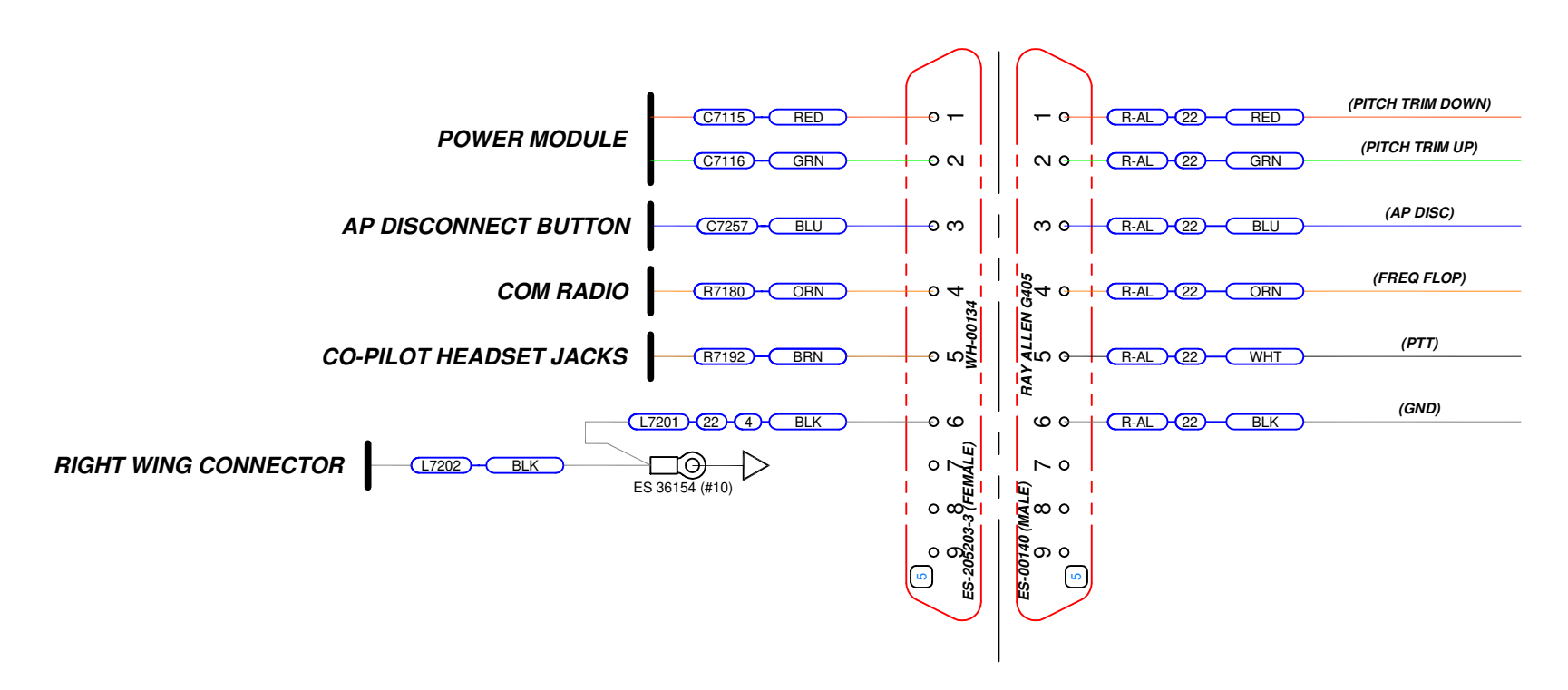

### LEFT WING CONNECTOR

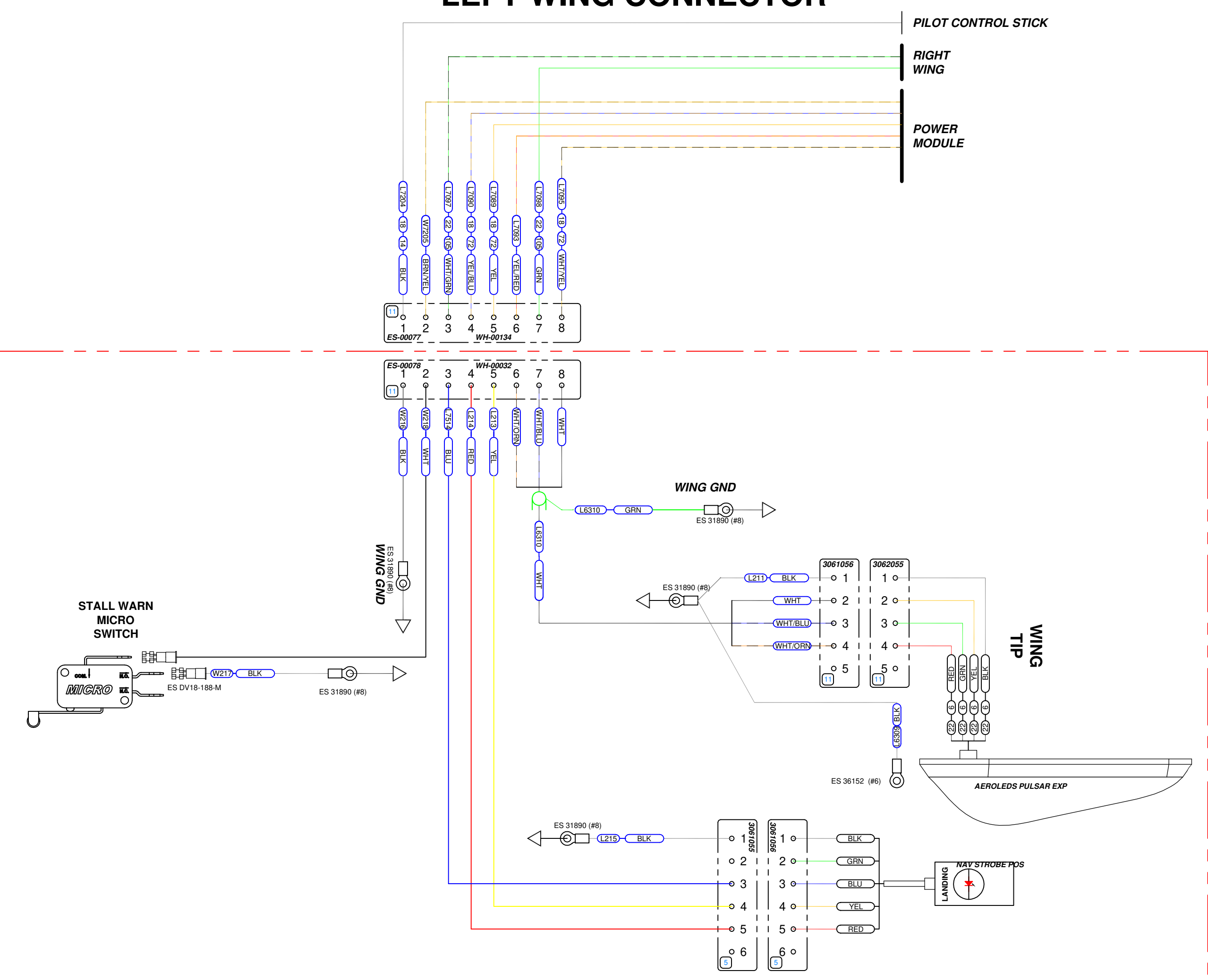

THESE COMPONENTS NOT INCLUDED IN AVIONICS KIT, NOR PART OF THE WH-00134.  
SEE WH-00032 AND WH-00033 RV-12IS WING HARNESS DRAWINGS

### RIGHT WING CONNECTOR

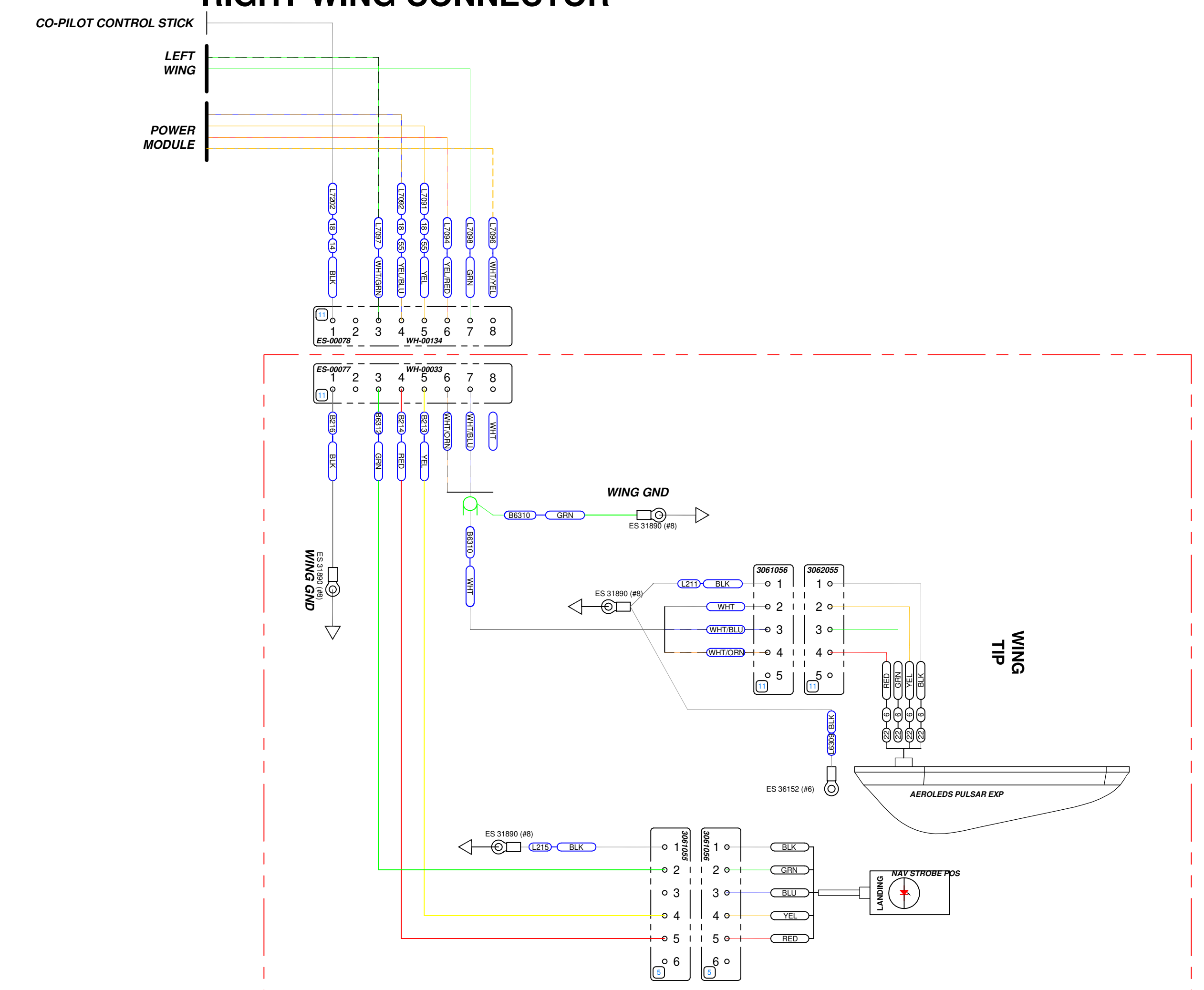

THESE COMPONENTS NOT INCLUDED IN AVIONICS KIT, NOR PART OF THE WH-00134.  
SEE WH-00032 AND WH-00033 RV-12IS WING HARNESS DRAWINGS

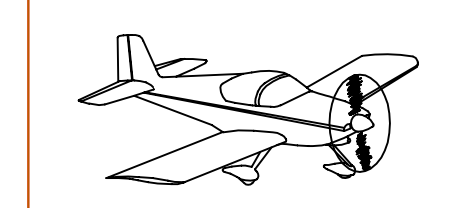

VAN'S AIRCRAFT, INC. 14401 NE KEIL RD. NE  
AURORA, OR 97002 USA

## ROTAX 912iS G3X ELECTRICAL SYSTEM

DATE DRAWN: 6/11/2018

DRAWN BY: T. DE MAN

TOLERANCES: NONE  
(UNLESS OTHERWISE SPECIFIED)

UNITS: INCHES  
SCALE: NONE

WH-00134  
PAGE: 3 OF 11

PATH:FILENAME: Q:\RV-12\System 1S\Electrical System 1S\Electrical System 912iS G3X (WH-00134).DWG C-SIZE ORIGINAL

REV	DESCRIPTION	DATE	APPROVAL
R6	SEE PAGE 1		

## COM-RADIO - TRIG TY96

USE TRIG BACKSHELL

1. TRIG TY-96 USED FOR INTERNATIONAL AVIONICS KIT ONLY
2. COVER UNUSED PINS WITH HEAT SHRINK AND SECURE TO HARNESS NEAR TY96 CONNECTOR

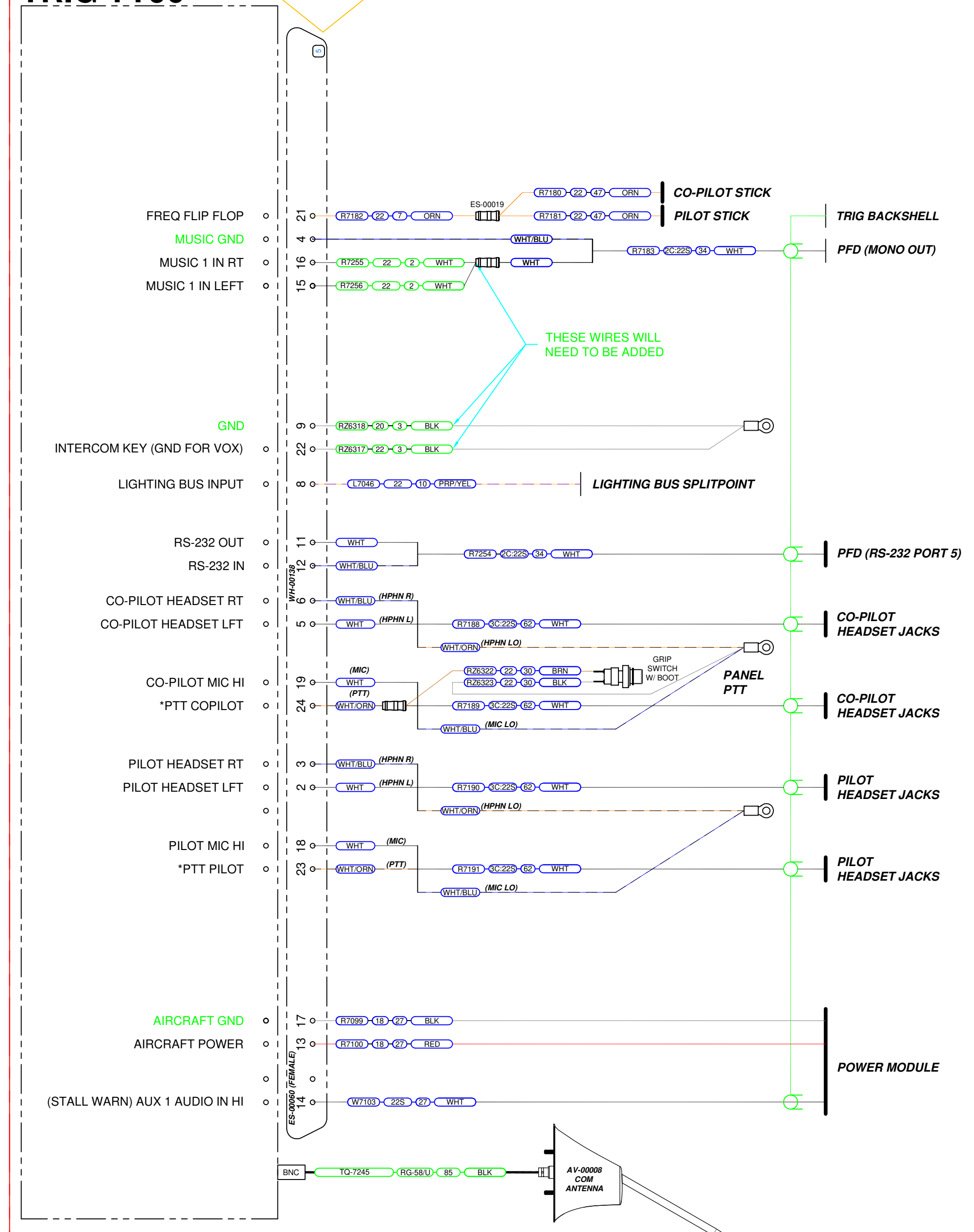

## COM RADIO - GTR 200B

USE GARMIN BACKSHELL

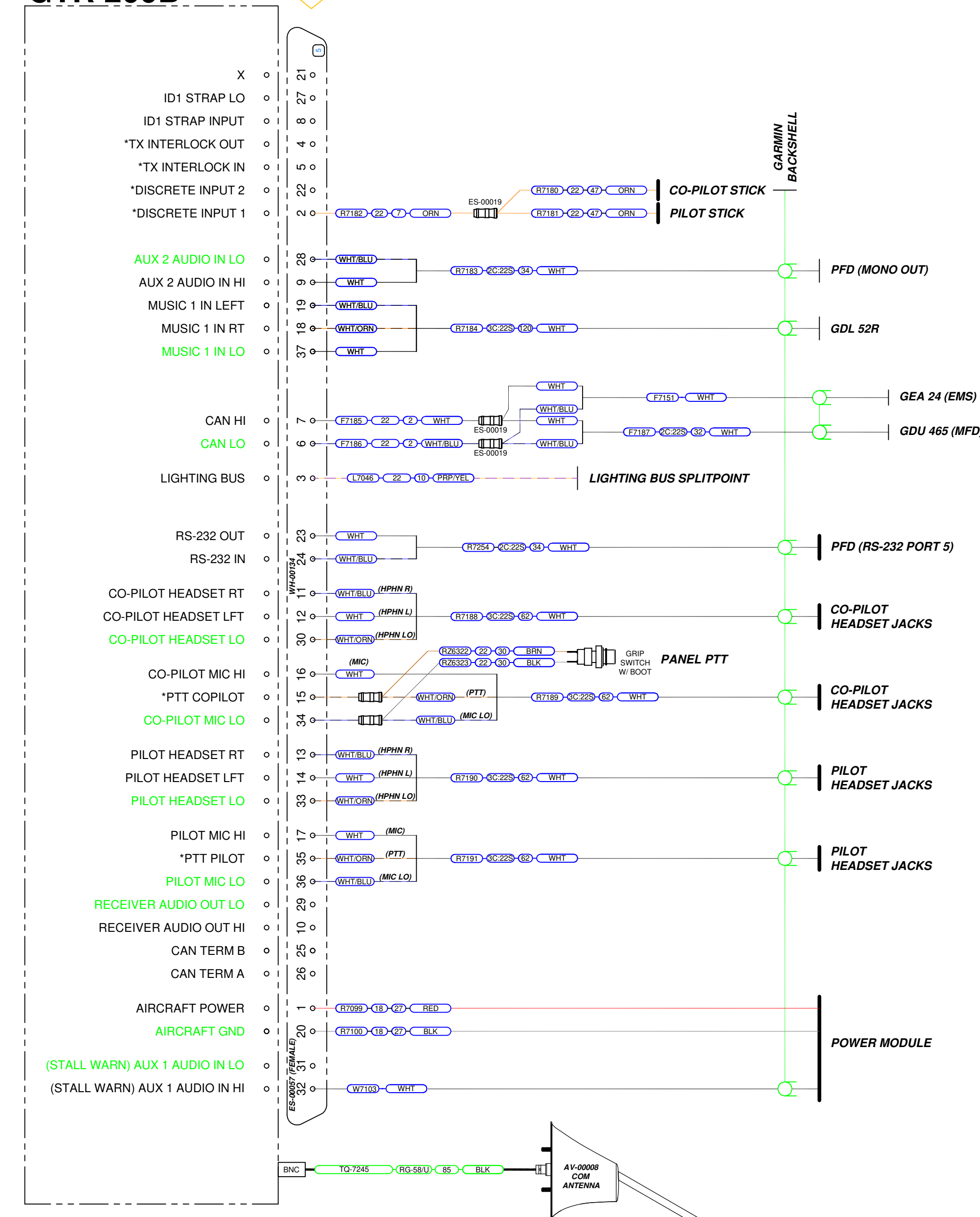

### CO-PILOT HEADSET JACKS

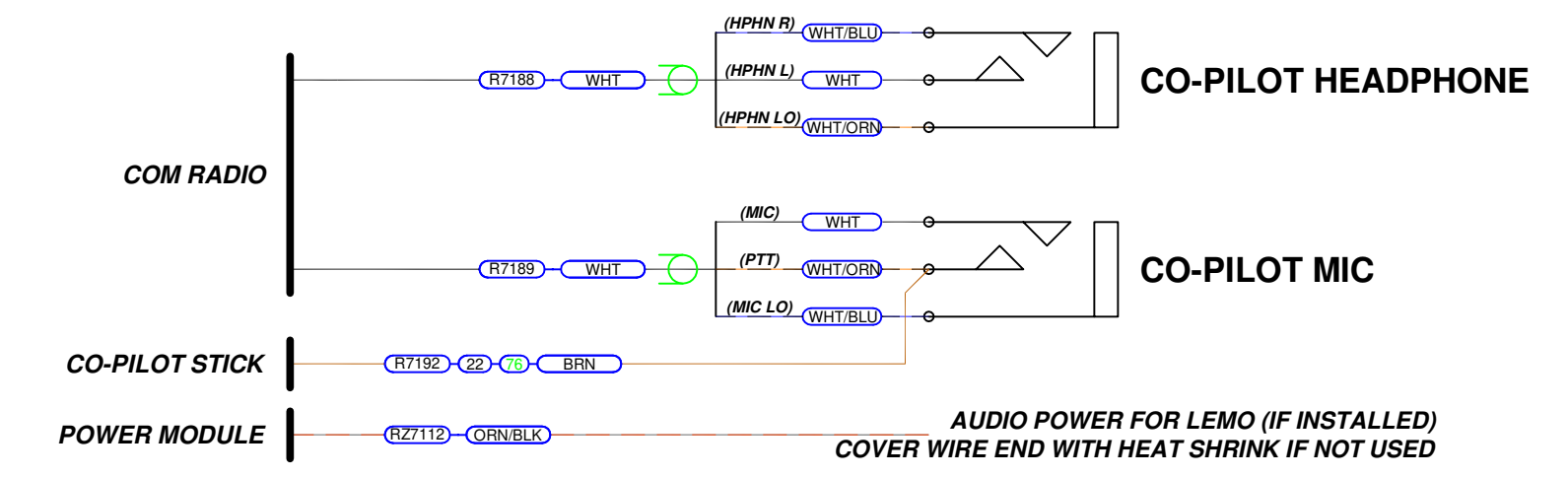

### PILOT HEADSET JACKS

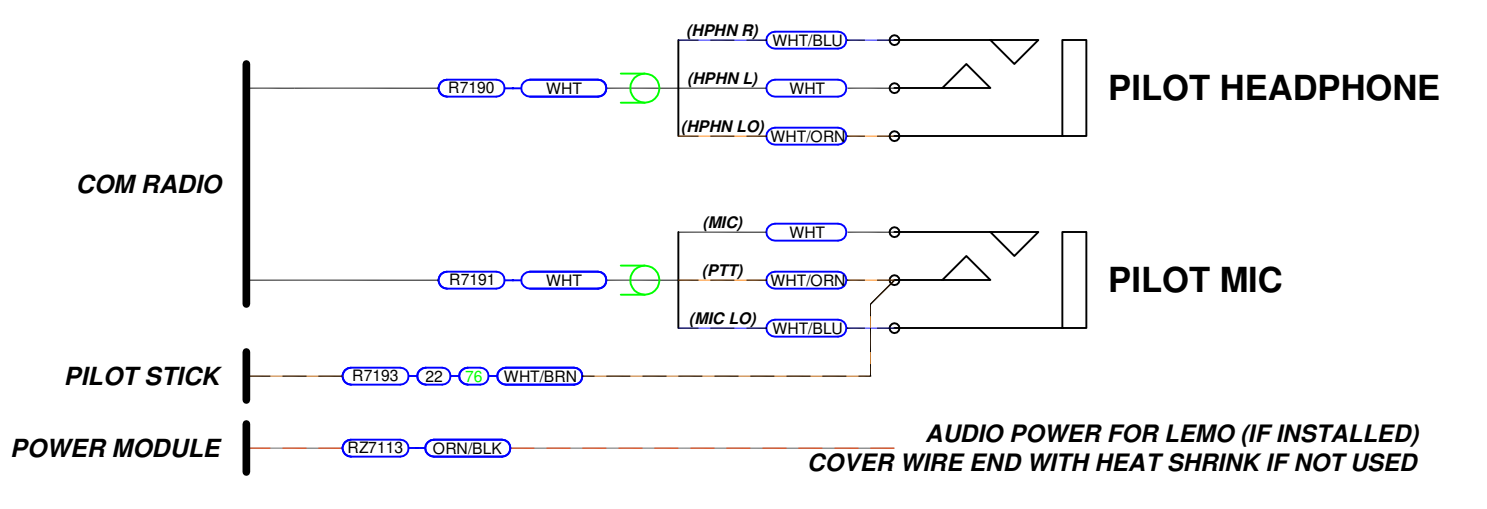

### OPTIONAL AUDIO OUTPUT

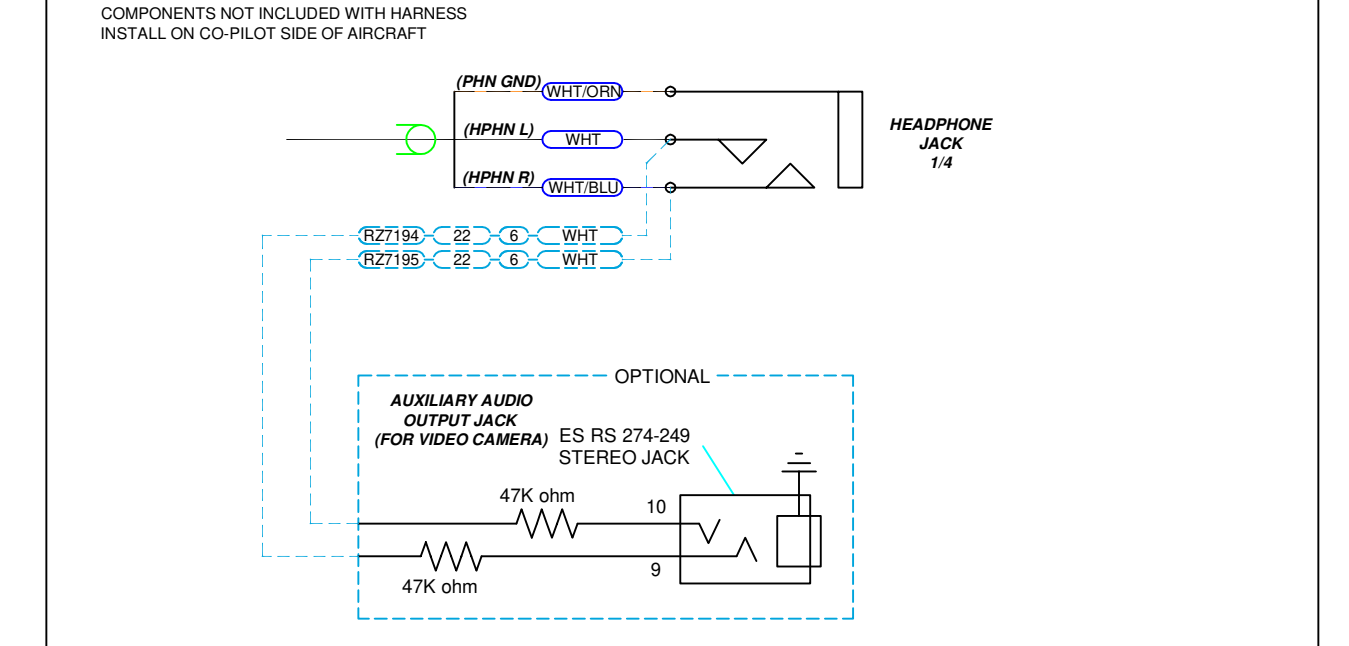

### OPTIONAL LEMO JACK

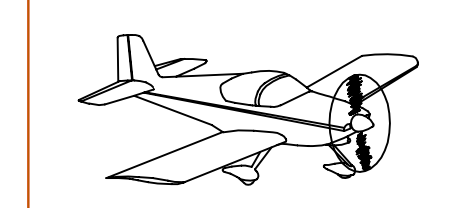
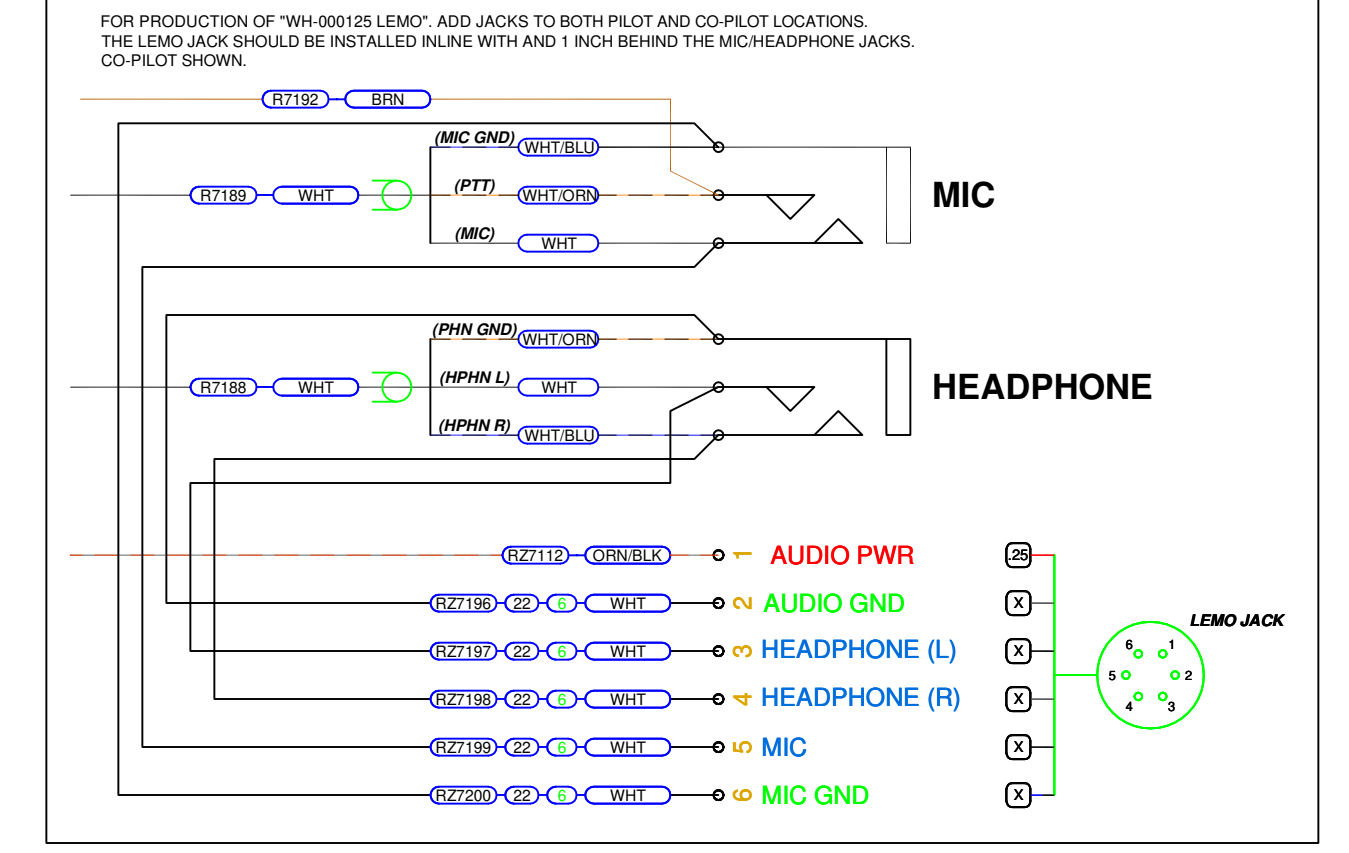

VAN'S AIRCRAFT, INC. 14401 NE KEIL RD. NI AURORA, OR 97002 USA

## ROTAX 912iS G3X ELECTRICAL SYSTEM

DATE DRAWN: 6/11/2018

DRAWN BY: T. DE MAN

TOLERANCES: NONE (UNLESS OTHERWISE SPECIFIED)

UNITS: INCHES  
SCALE: NONE  
PAGE: 4 OF 11

PATH:FILENAME: Q:\RV-12\System 12\Electrical System 12\Electrical System 12iS G3X (WH-00134).DWG C-SIZE ORIGINAL

REV	DESCRIPTION	DATE	APPROVAL
R6	SEE PAGE 1		

### AUTOPILOT PITCH SERVO

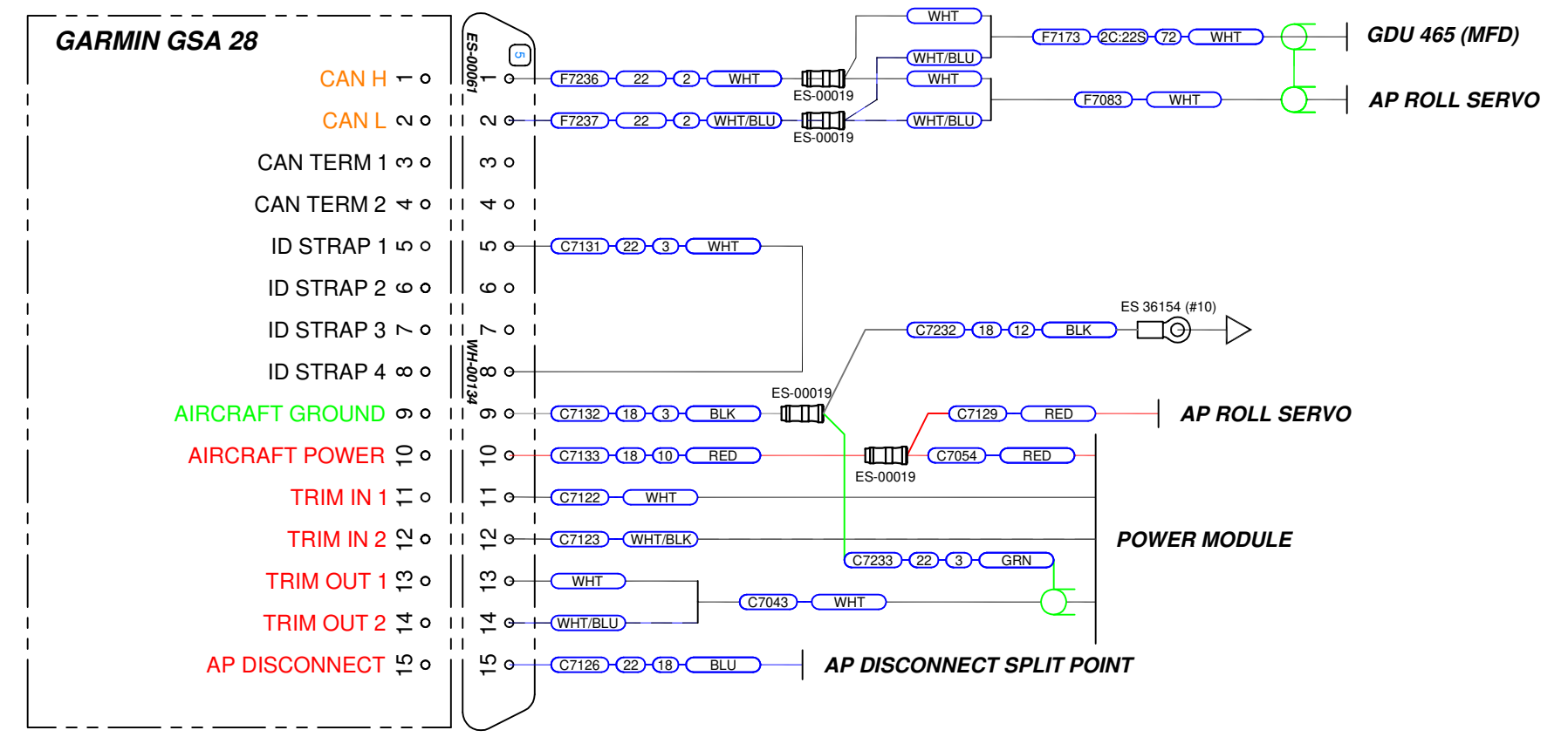

### AUTOPILOT ROLL SERVO

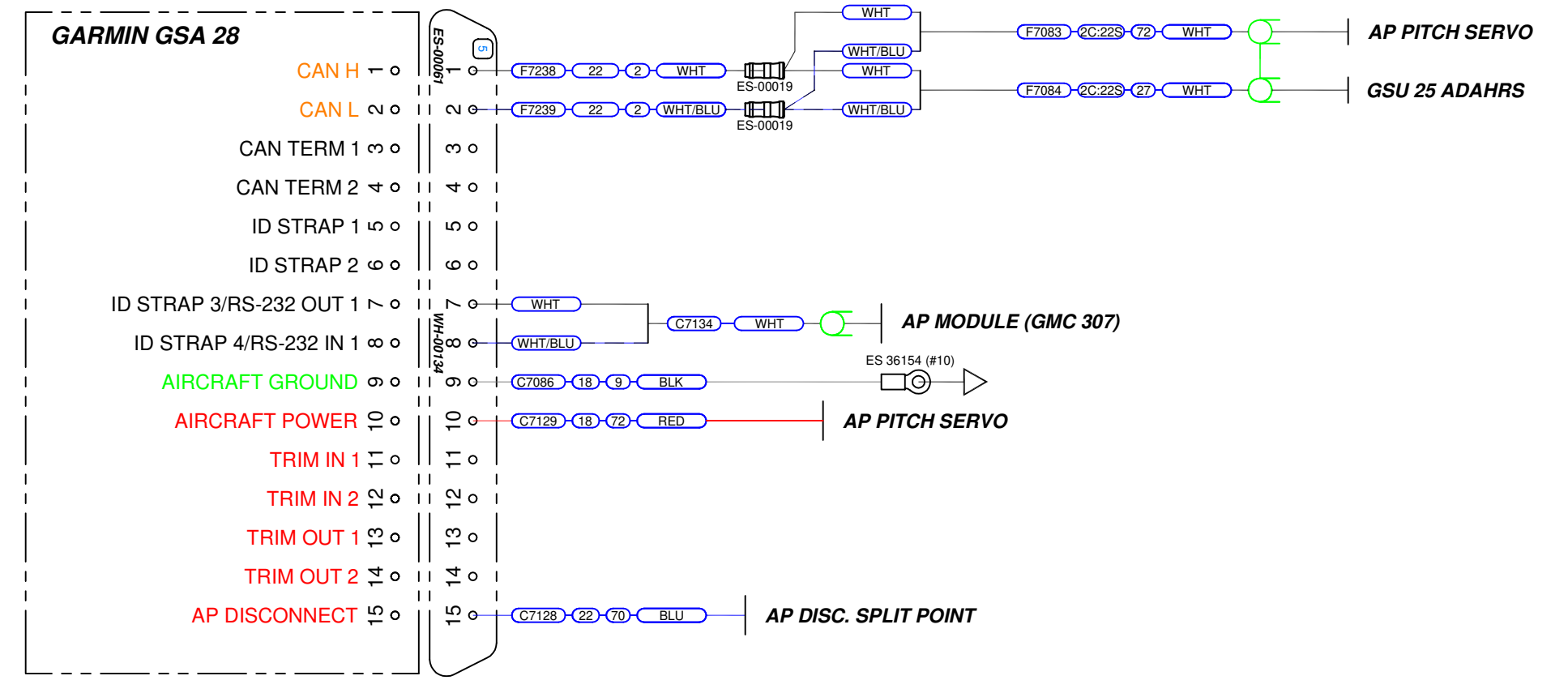

### TRIM MOTOR

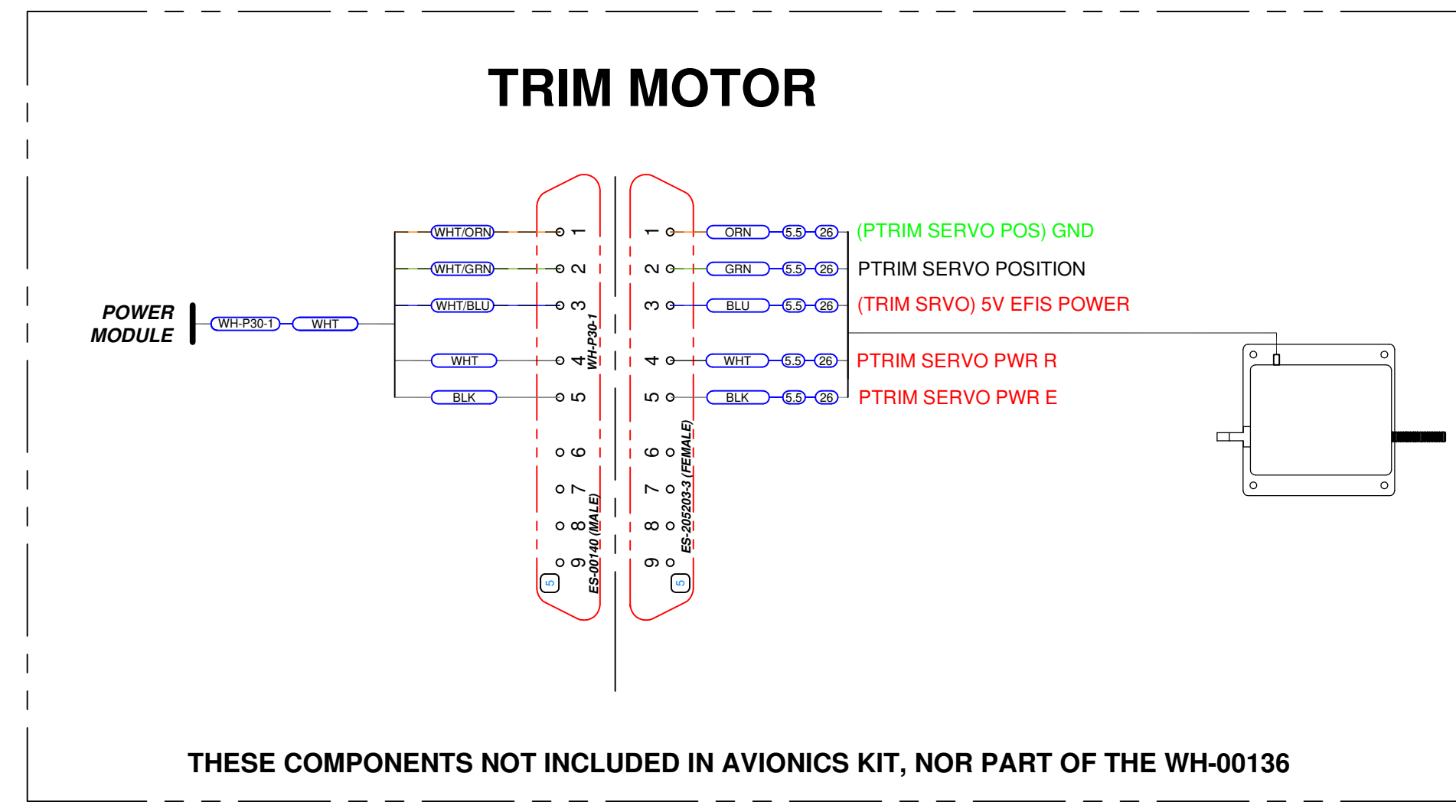

### AP DISCONNECT

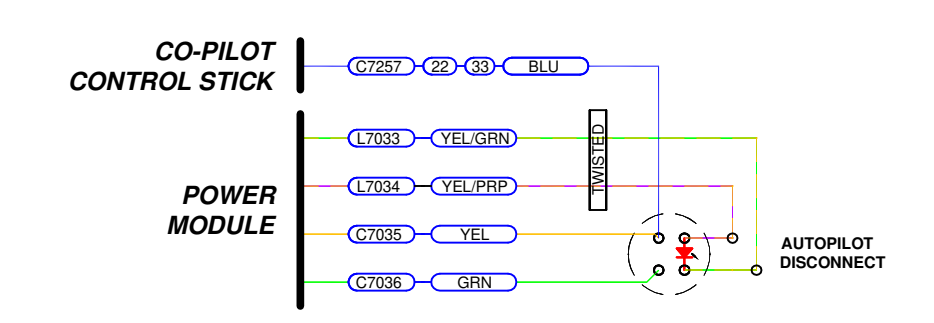

### WAAS POSITION

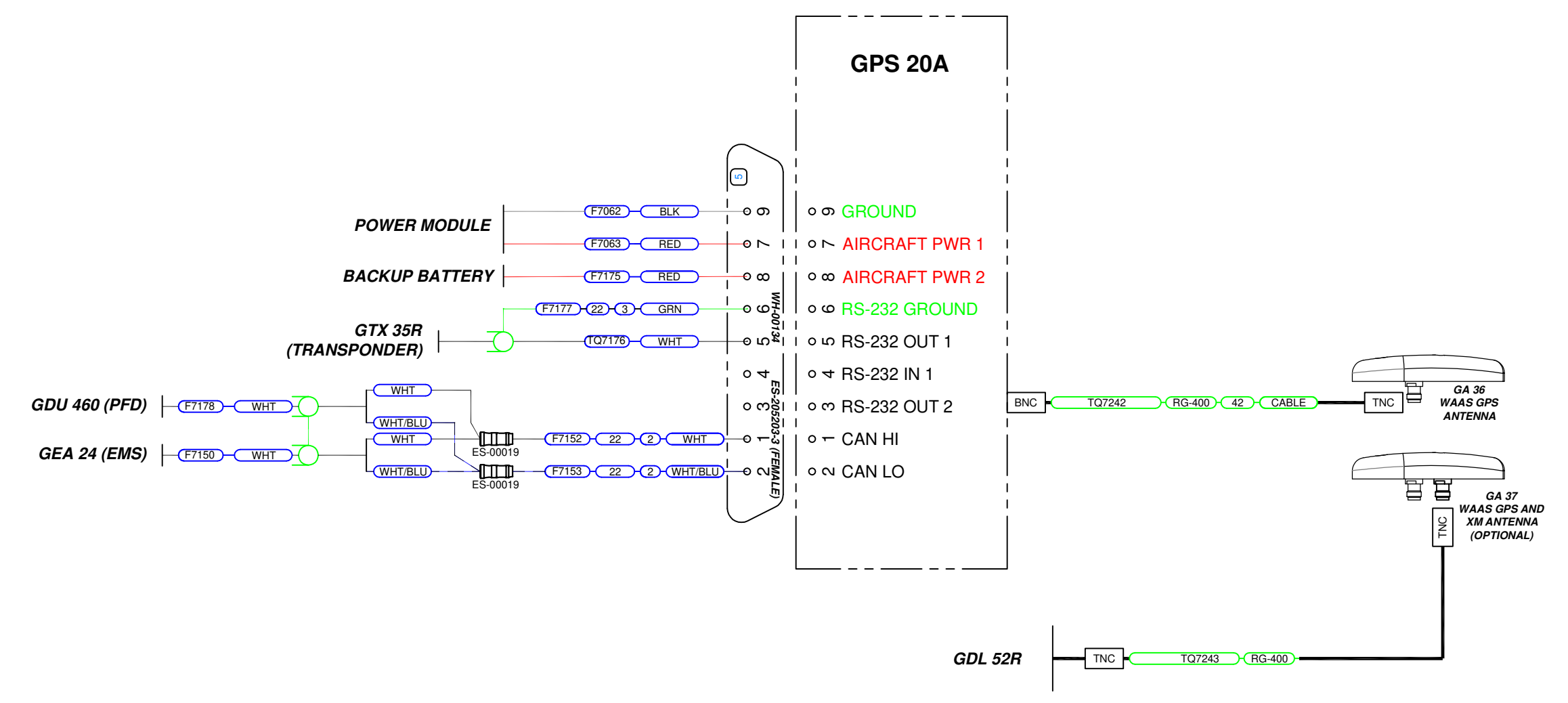

### MAGNETOMETER

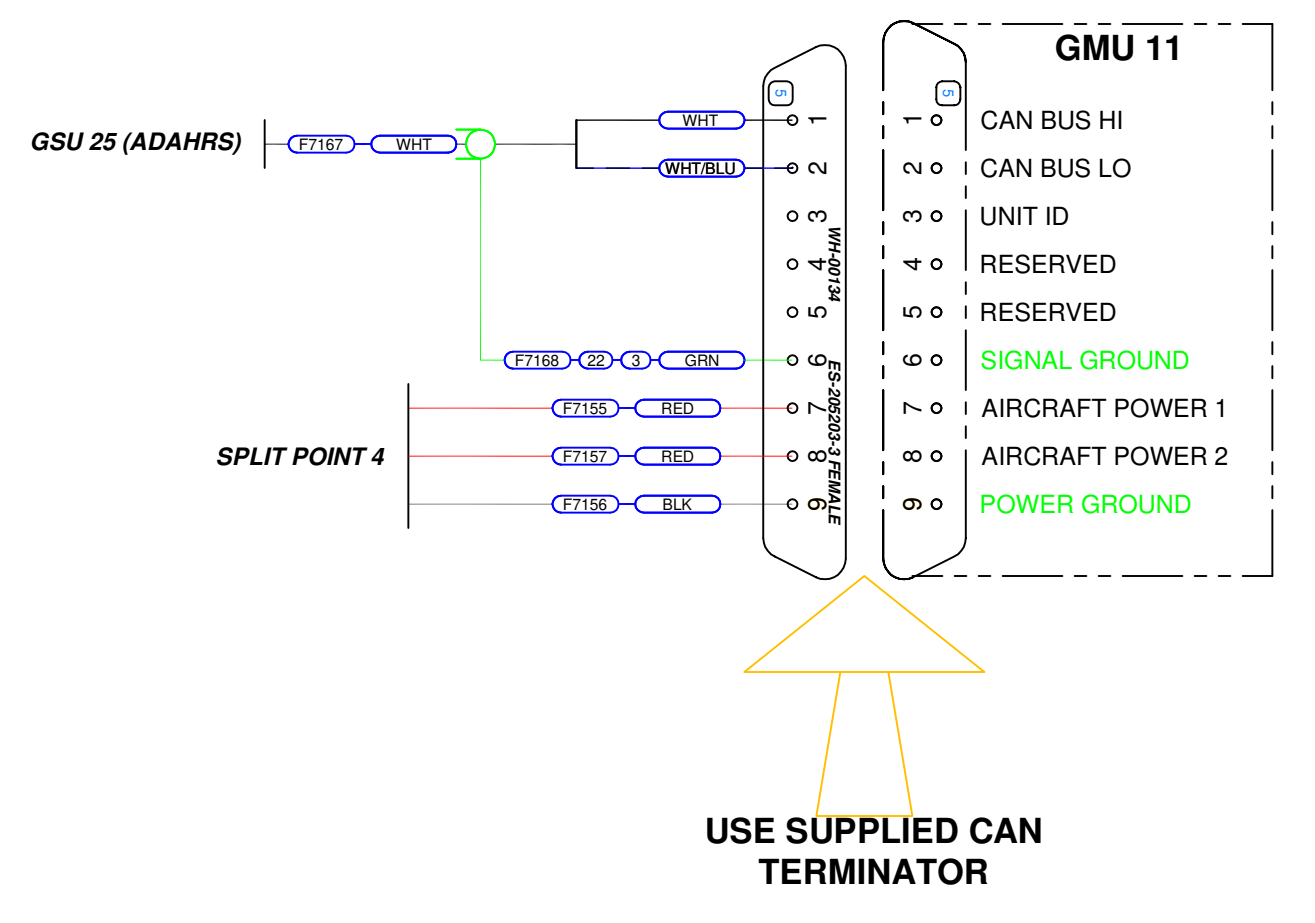

### AP MODULE

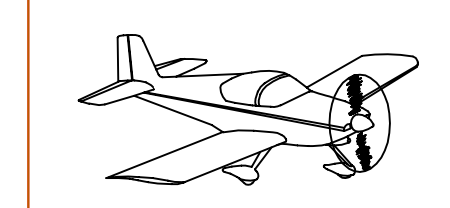
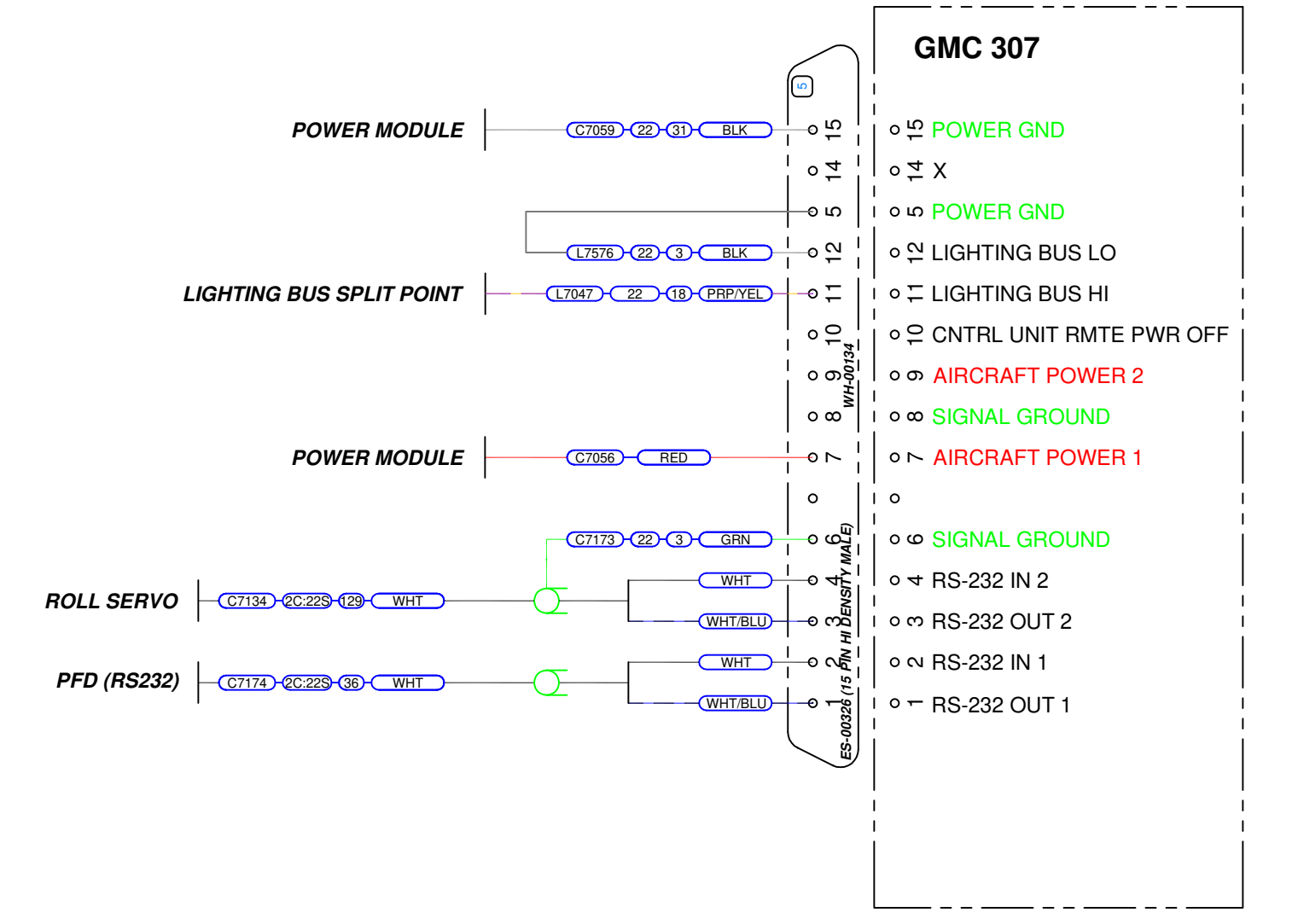

VAN'S AIRCRAFT, INC. 14401 NE KEIL RD. NI AURORA, OR 97002 USA

### ROTAX 912iS G3X ELECTRICAL SYSTEM

DATE DRAWN: 6/11/2018

DRAWN BY: T. DE MAN

TOLERANCES: NONE (UNLESS OTHERWISE SPECIFIED)

UNITS: INCHES WH-00134

SCALE: NONE PAGE: 5 OF 11

PATH:FILENAME: Q:\RV-12\System 5\Electrical System 5\Electrical System 912iS G3X (WH-00134).DWG C-SIZE ORIGINAL

### POWER OUTLET

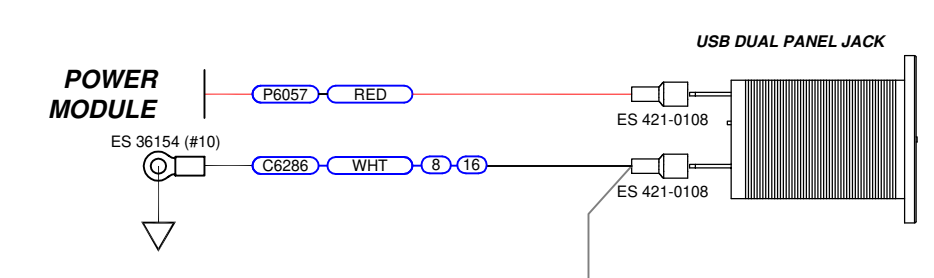

### FLAP MOTOR

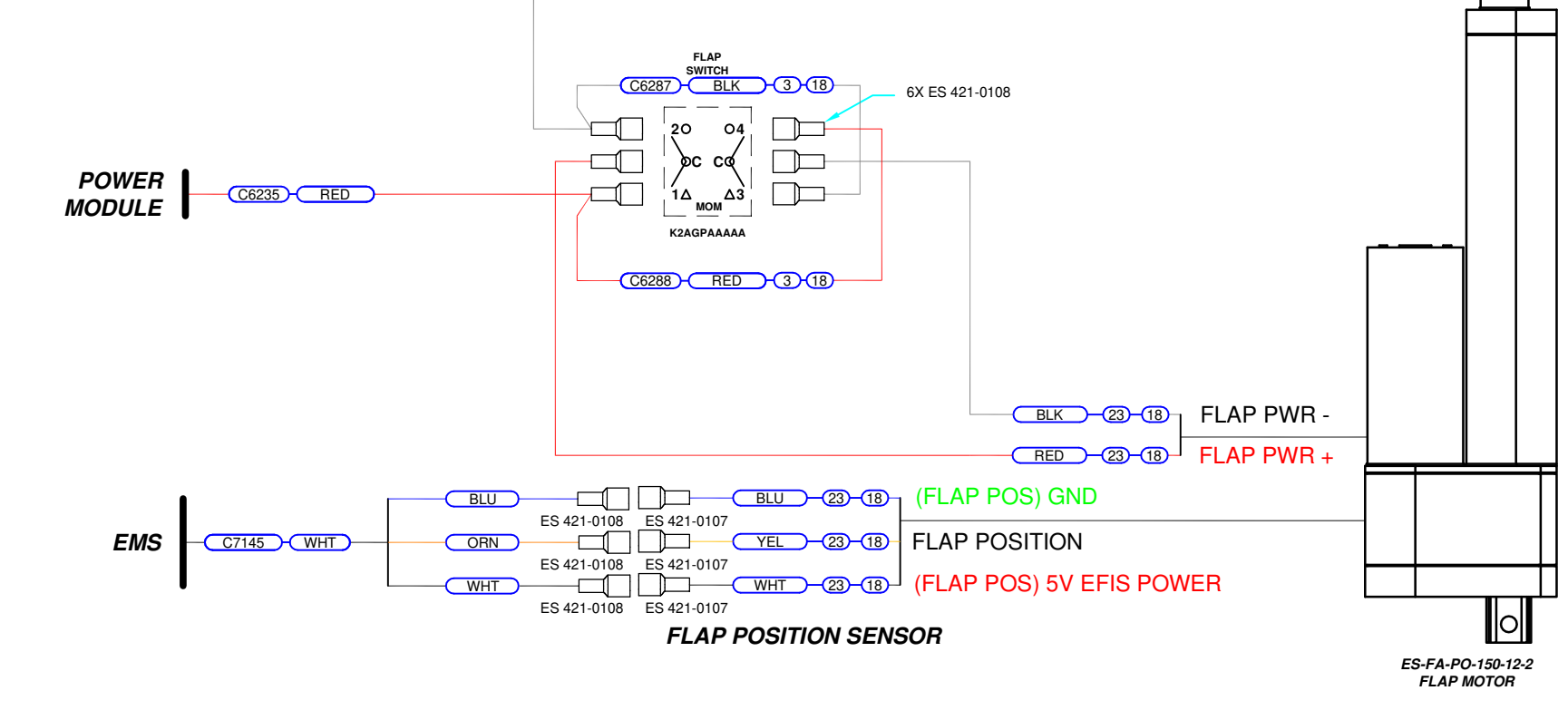

### SPLIT POINT 5

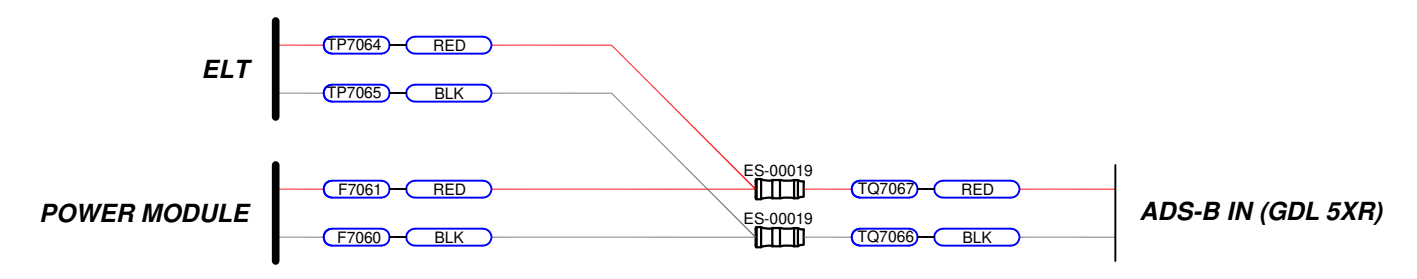

### SPLIT POINT 1

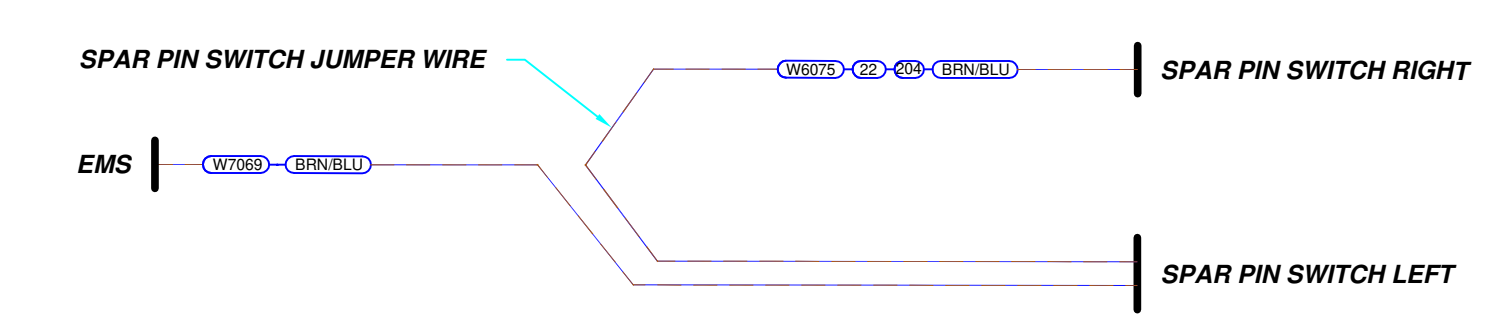

### LIGHTING BUS SPLIT

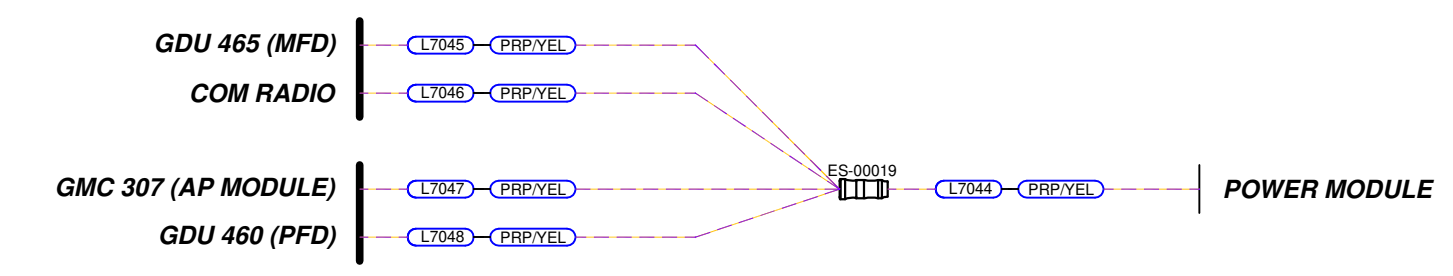

### SPLIT POINT 4

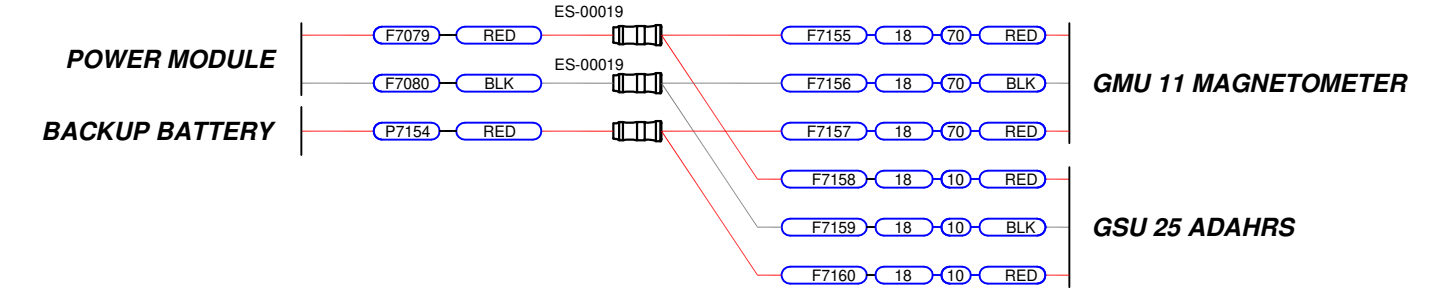

### AUTOPILOT DISC. SPLIT POINT

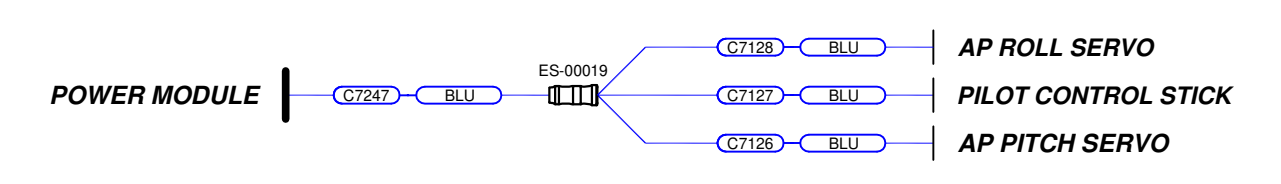

### ADAHRS

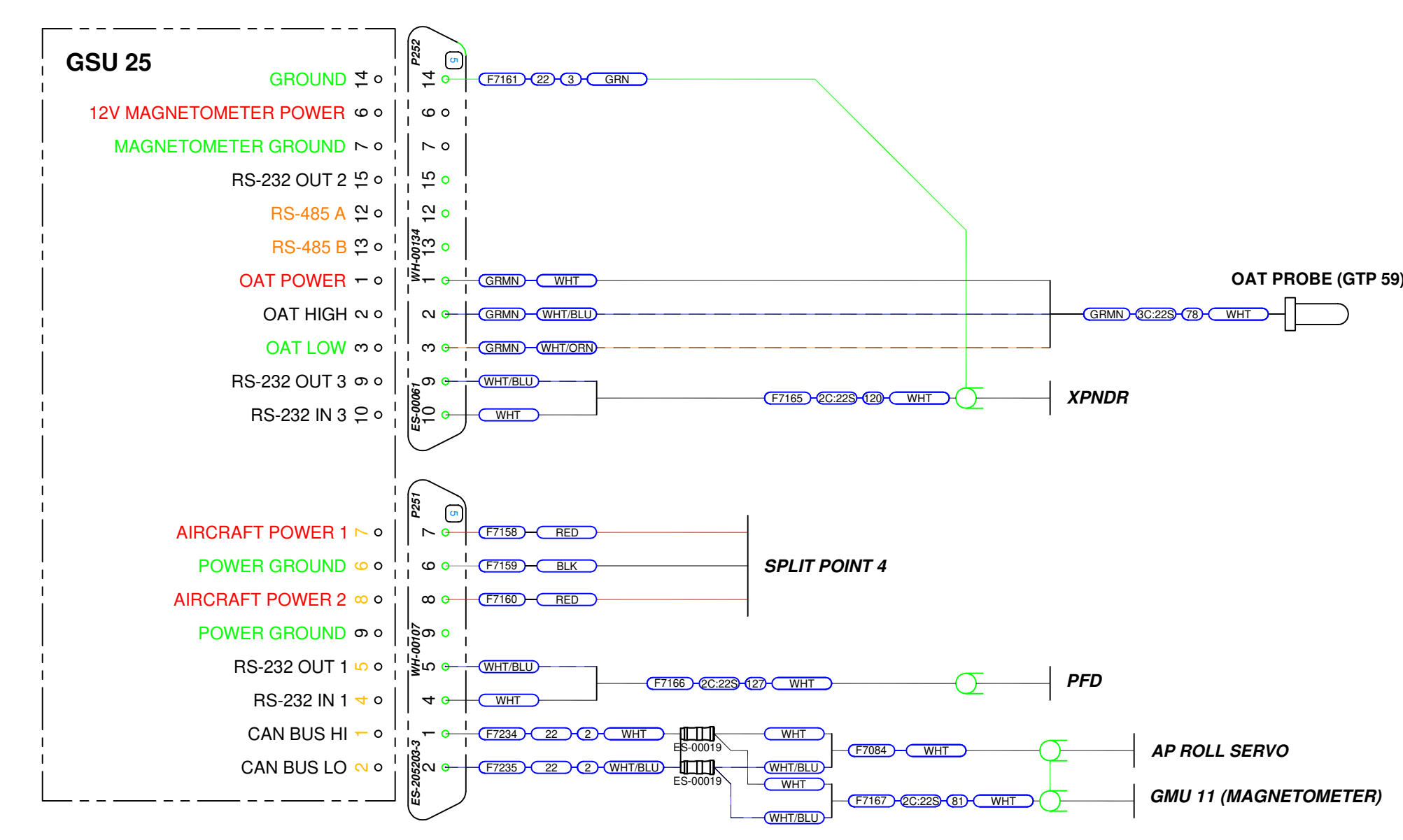

### EFIS BATTERY SWITCH

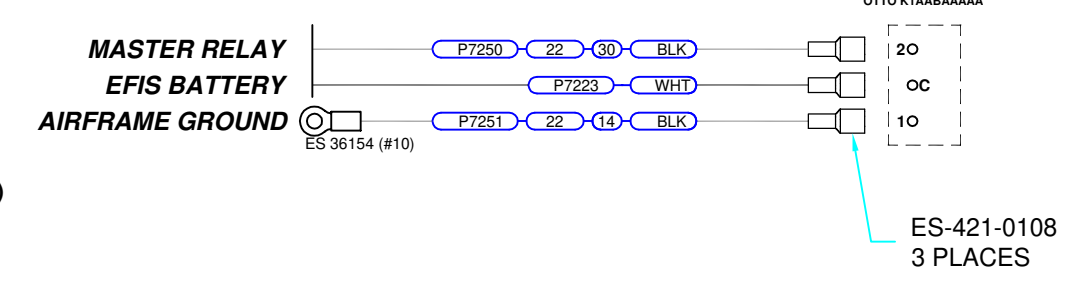

### ADS-B IN

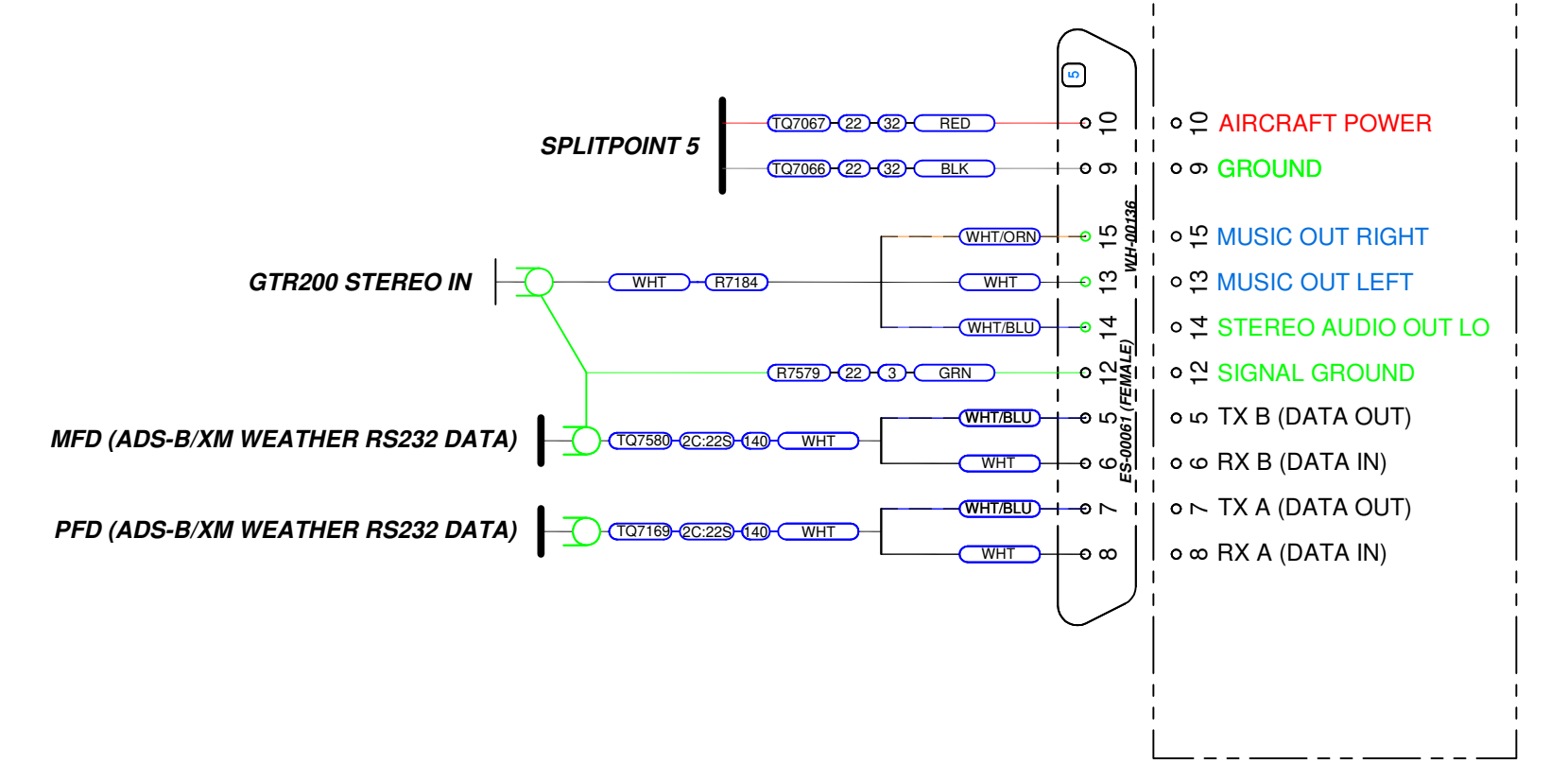

### ELT REMOTE

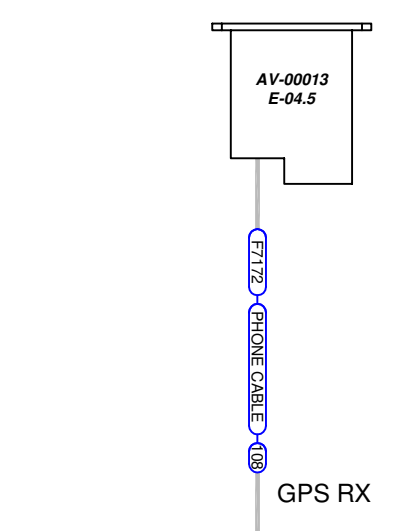

### ELT

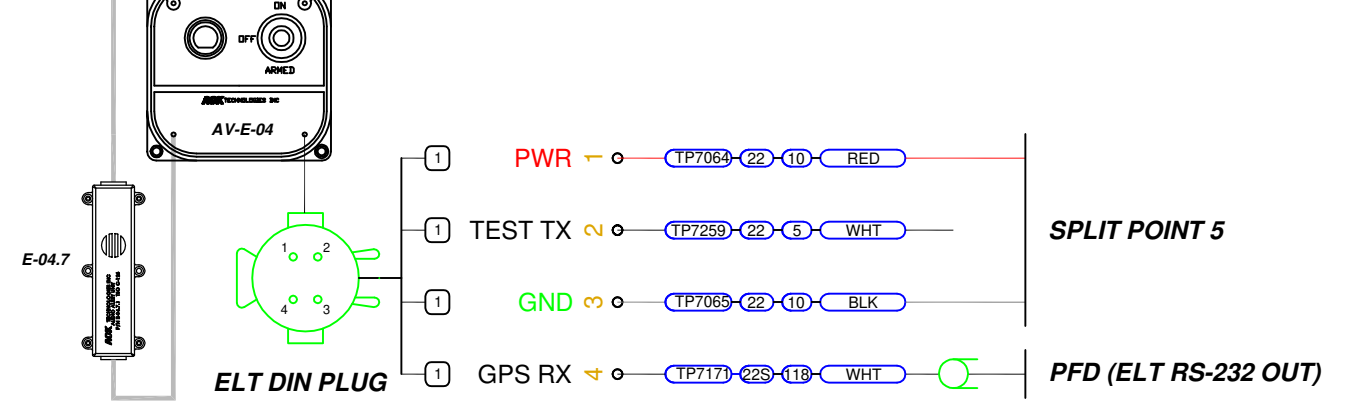

### SPAR PIN SWITCHES

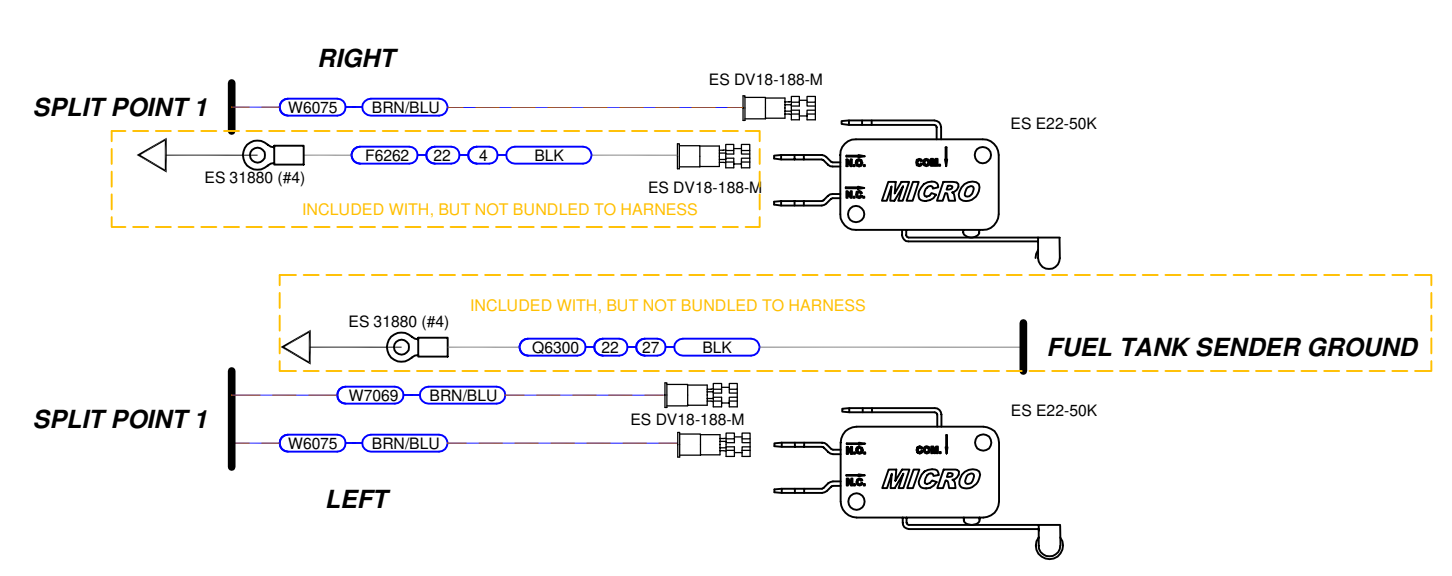

### CABIN LIGHT & DIMMER

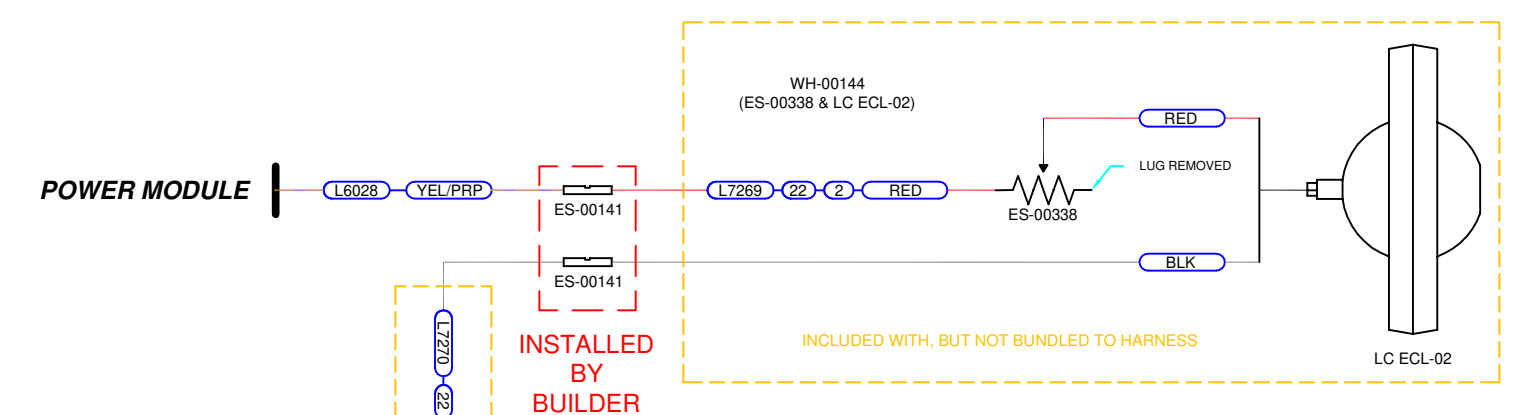

### CANOPY SWITCH

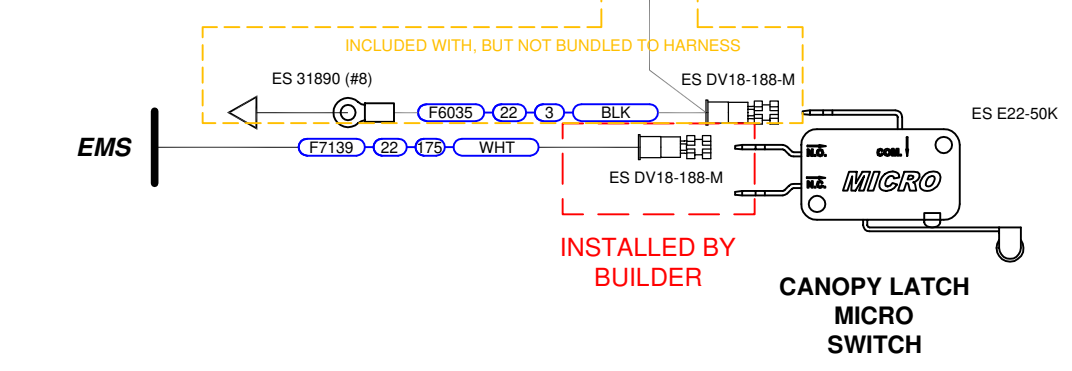

### 912iS MAINT PORT

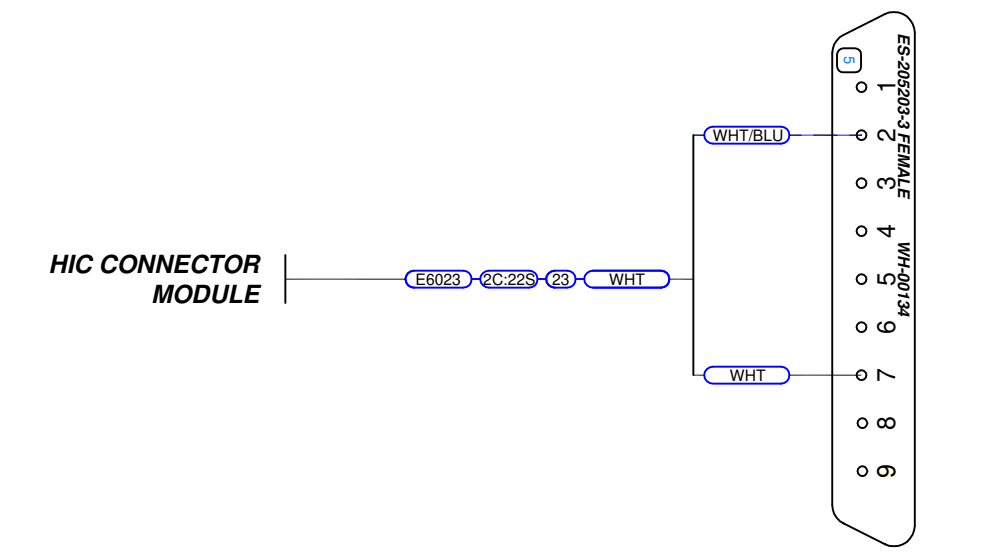

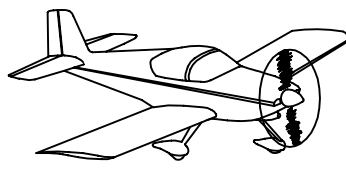

**VAN'S AIRCRAFT, INC.**  
14401 NE KEIL RD. NI  
AURORA, OR  
97002 USA

## ROTAX 912iS G3X ELECTRICAL SYSTEM

DATE DRAWN: 6/11/2018  
DRAWN BY: T. DE MAN  
TOLERANCES: NONE  
(UNLESS OTHERWISE SPECIFIED)SCALE: NONE  
PAGE: 6 OF 11  
PATH:FILENAME: Q:\RV-12\System 912iS\Electrical System 912iS G3X (WH-00134).DWG  
C-SIZE ORIGINAL

REV	DESCRIPTION	DATE	APPROVAL
R6	SEE PAGE 1		

# EMS

## GEA 24

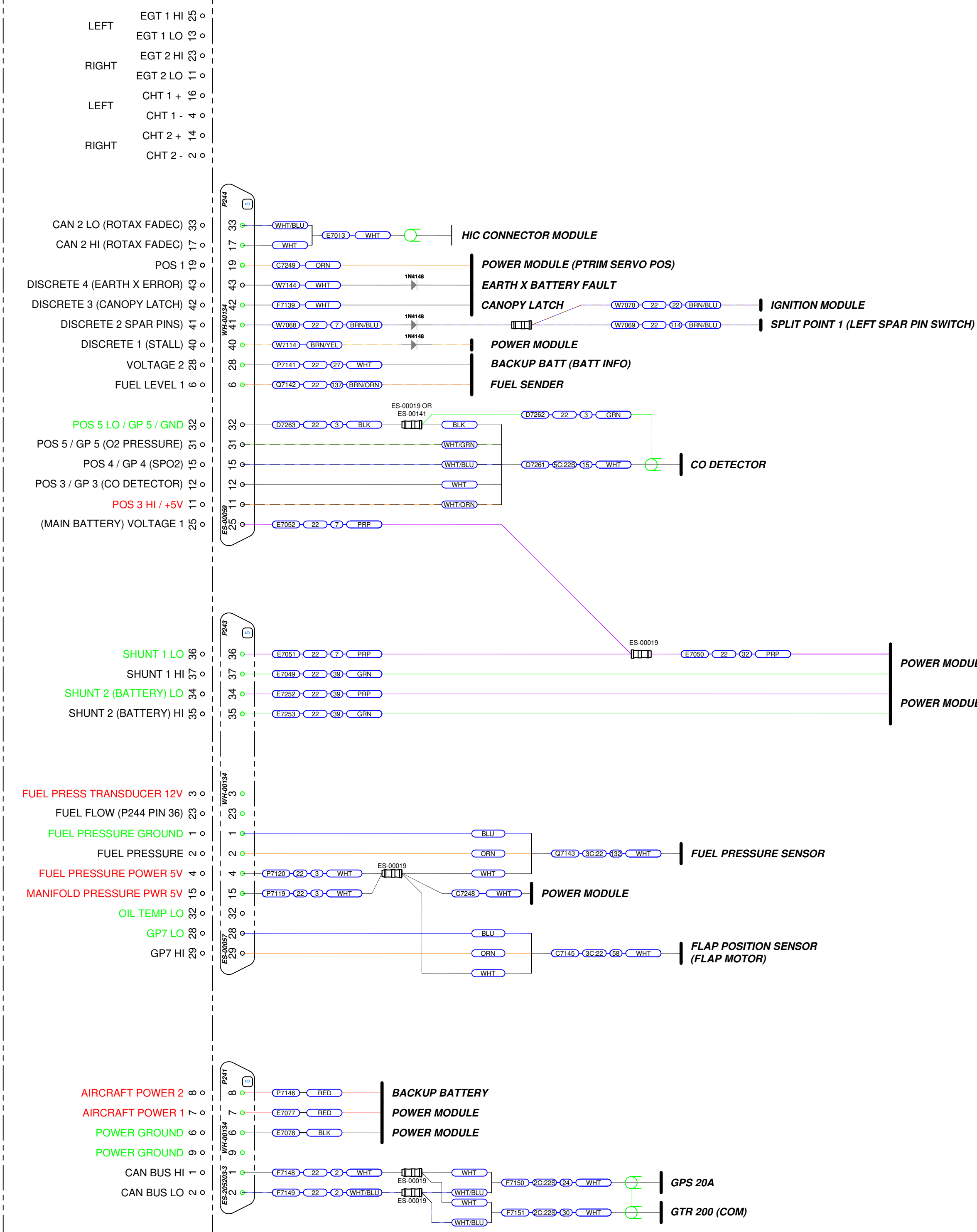

### FUEL SENDER

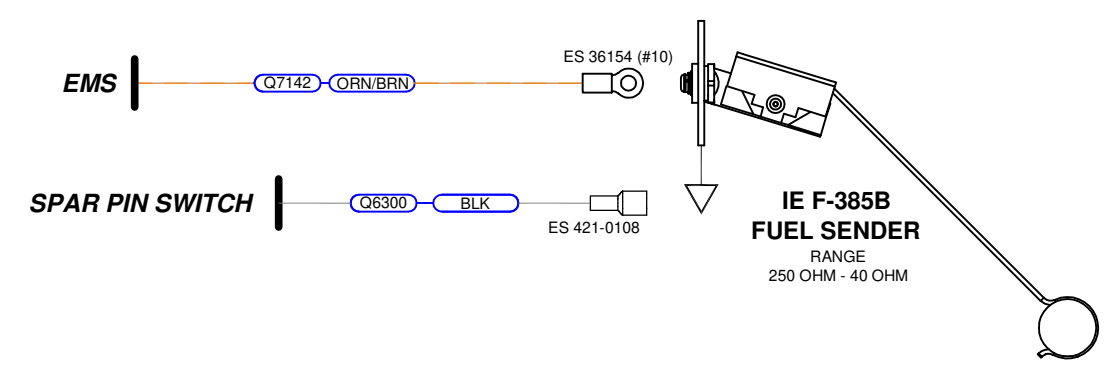

### CO DETECTOR

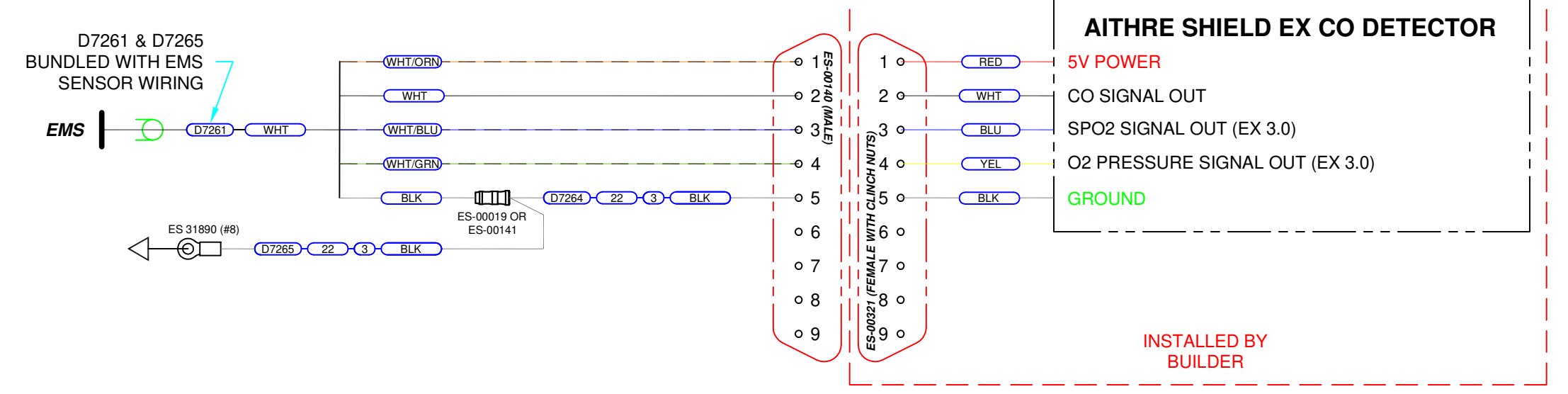

### FUEL PRESSURE SENSOR

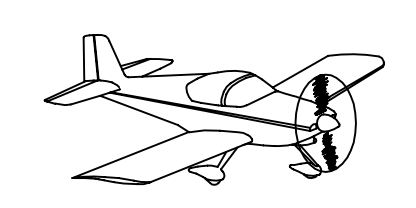
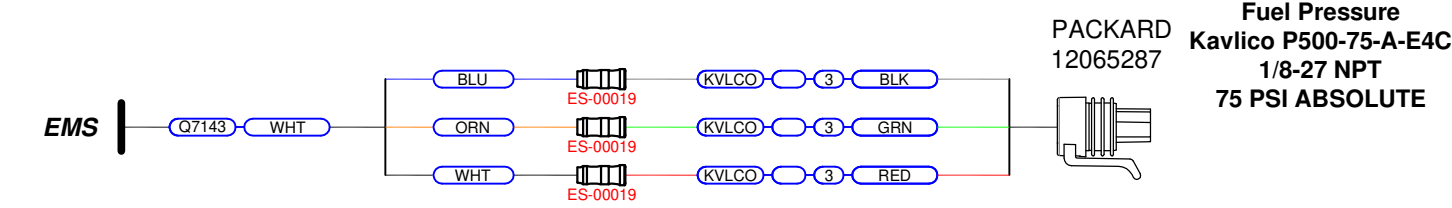

VAN'S AIRCRAFT, INC. 14401 NE KEIL RD. NI AURORA, OR 97002 USA

## ROTAX 912iS G3X ELECTRICAL SYSTEM

DATE DRAWN: 6/11/2018

DRAWN BY: T. DE MAN

TOLERANCES: NONE (UNLESS OTHERWISE SPECIFIED)

UNITS: INCHES  
SCALE: NONE

WH-00134

SCALE: NONE PAGE: 7 OF 11

PATH:FILENAME: Q:\RV-12\System 5\Electrical System 5\Electrical System 912iS G3X (WH-00134).DWG C-SIZE ORIGINAL

# POWER MODULE iS-ULS PCB V3.4

REV	DESCRIPTION	DATE	APPROVAL
R6	SEE PAGE 1		

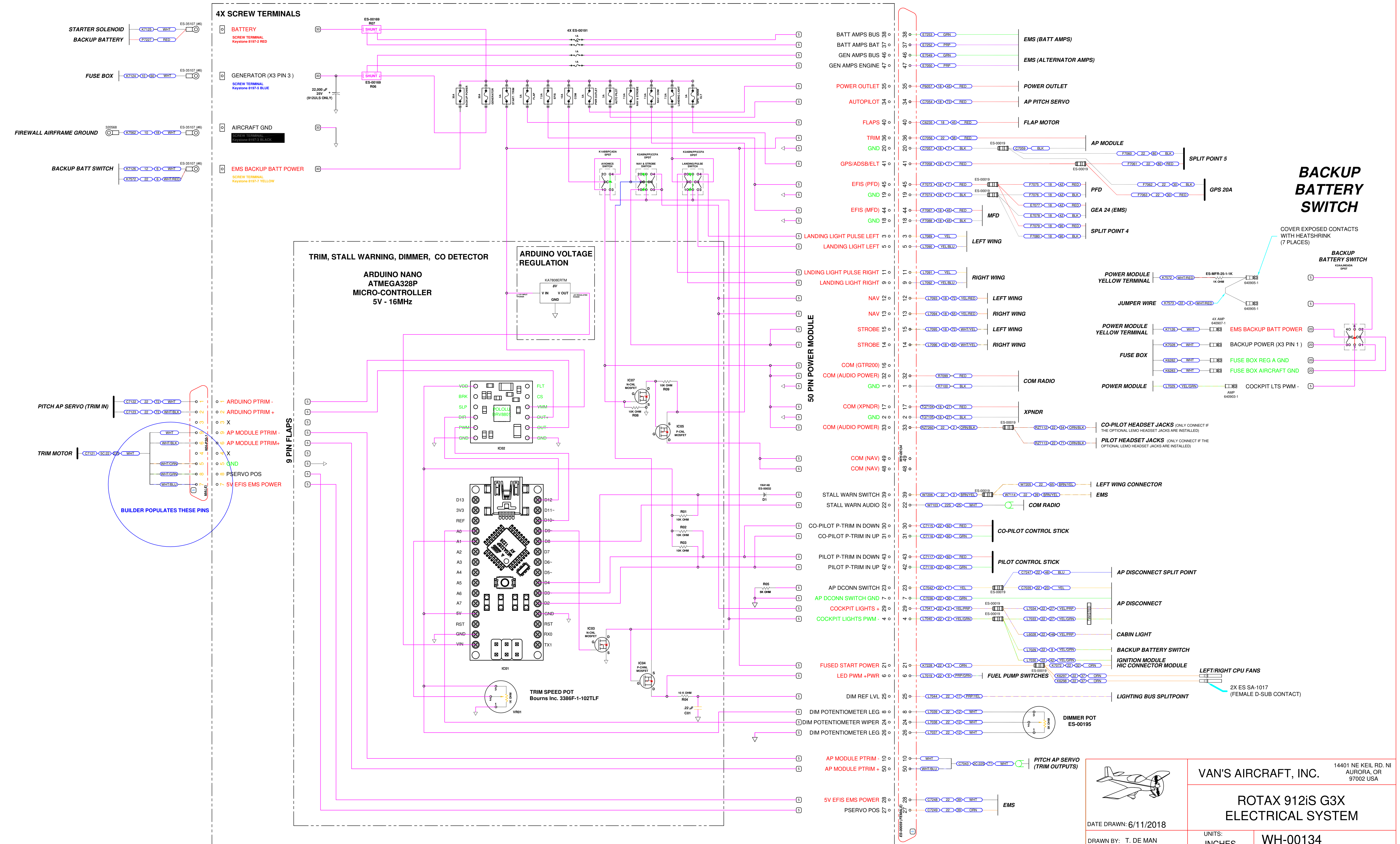

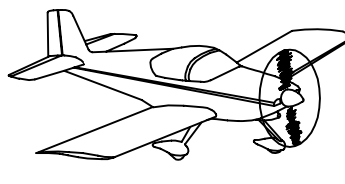

**VAN'S AIRCRAFT, INC.**

14401 NE KEIL RD. NI  
AURORA, OR  
97002 USA

**ROTAX 912iS G3X  
ELECTRICAL SYSTEM**

DATE DRAWN: 6/11/2018		UNITS: INCHES	WH-00134
DRAWN BY: T. DE MAN		SCALE: NONE	PAGE: 8 OF 11
TOLERANCES: NONE (UNLESS OTHERWISE SPECIFIED)		PATH:FILENAME: Q:\RV-12\System iS\Electrical System iS\Electrical System 912iS G3X (WH-00134).DWG	

C-SIZE ORIGINAL



# HIC CONNECTOR MODULE IS PCB ES-60009

REV	DESCRIPTION	DATE	APPROVAL
R6	SEE PAGE 1		

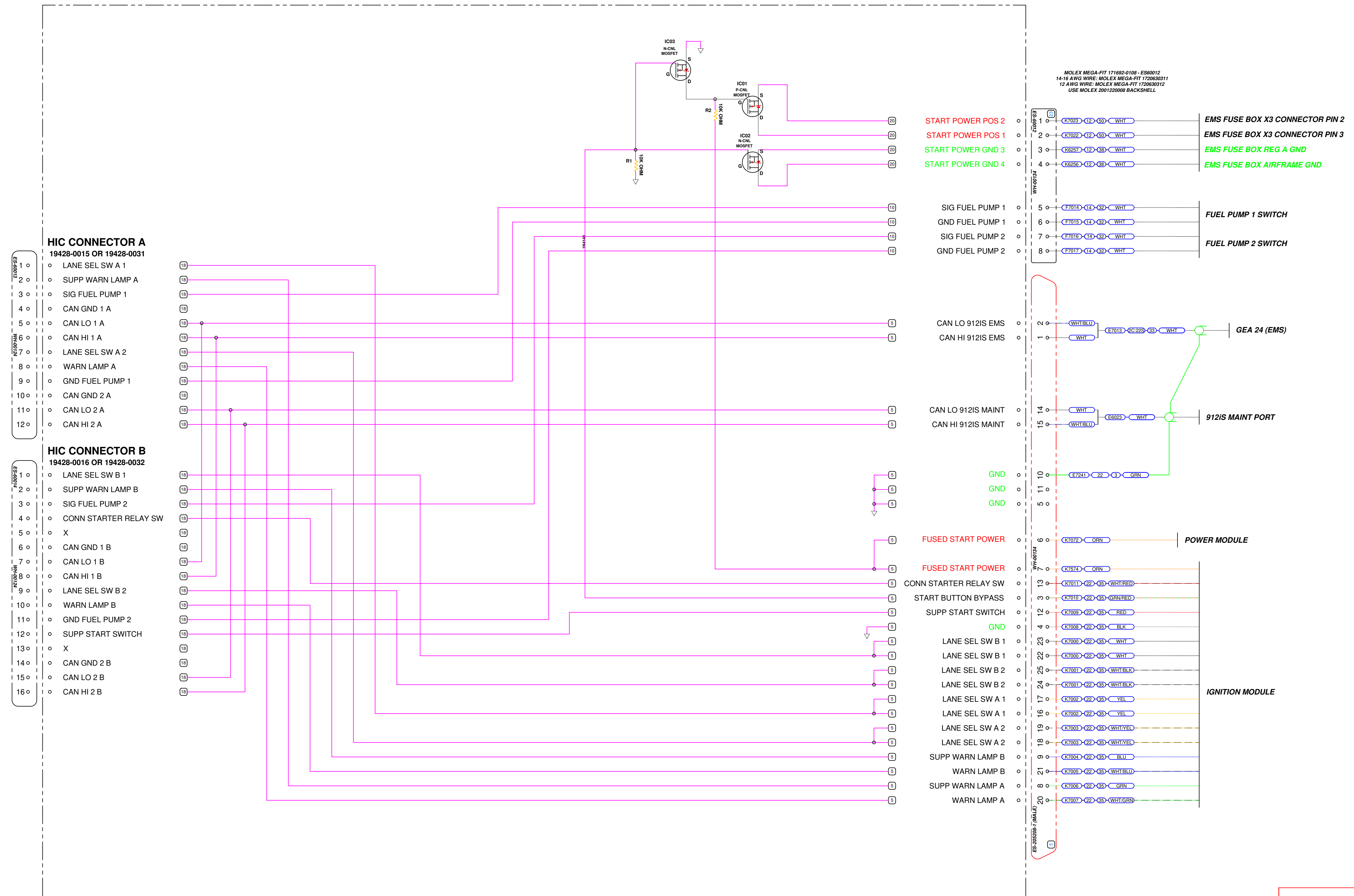

## FUEL PUMP SWITCHES

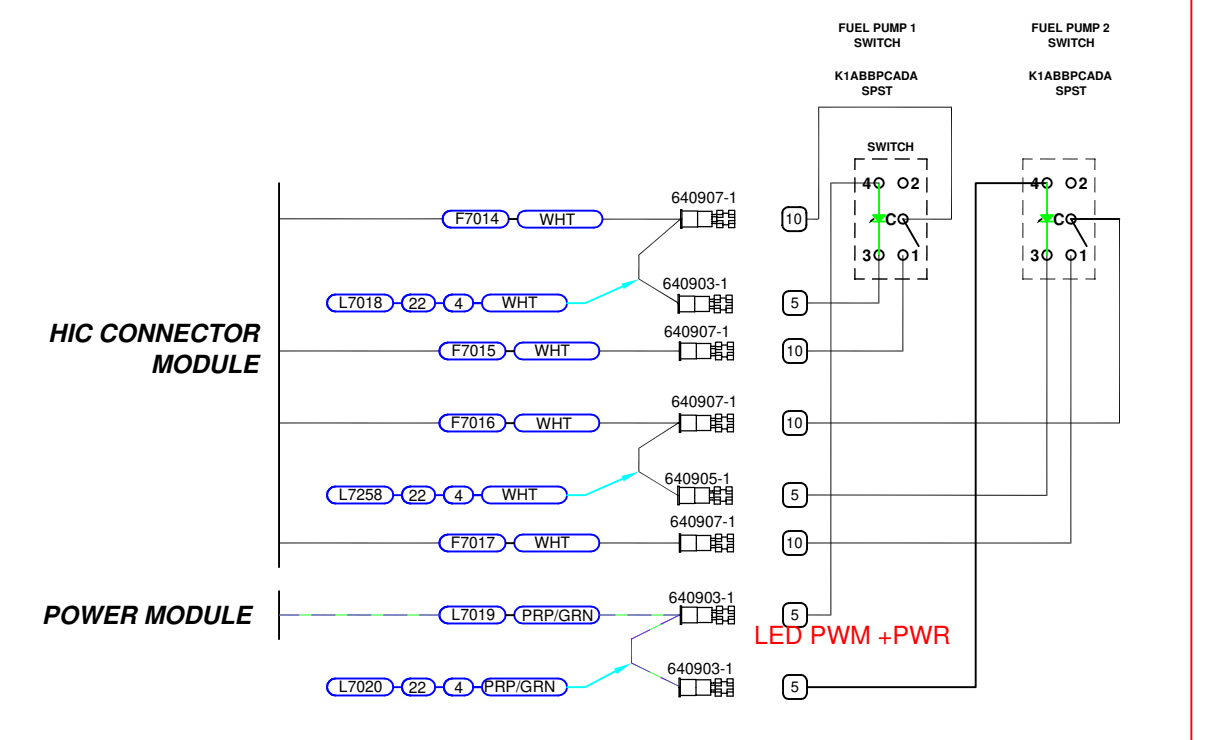

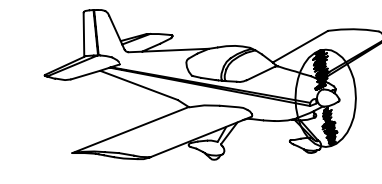

**VAN'S AIRCRAFT, INC.**

14401 NE KEIL RD. NI  
AURORA, OR  
97002 USA

### ROTAX 912iS G3X ELECTRICAL SYSTEM

DATE DRAWN: 6/11/2018		UNITS: INCHES	WH-00134
DRAWN BY: T. DE MAN		SCALE: NONE	
TOLERANCES: NONE (UNLESS OTHERWISE SPECIFIED)		PAGE: 9 OF 11	

PATH:FILENAME: Q:\RV-12\System 912iS Electrical System 912iS G3X (WH-00134).DWG C-SIZE ORIGINAL

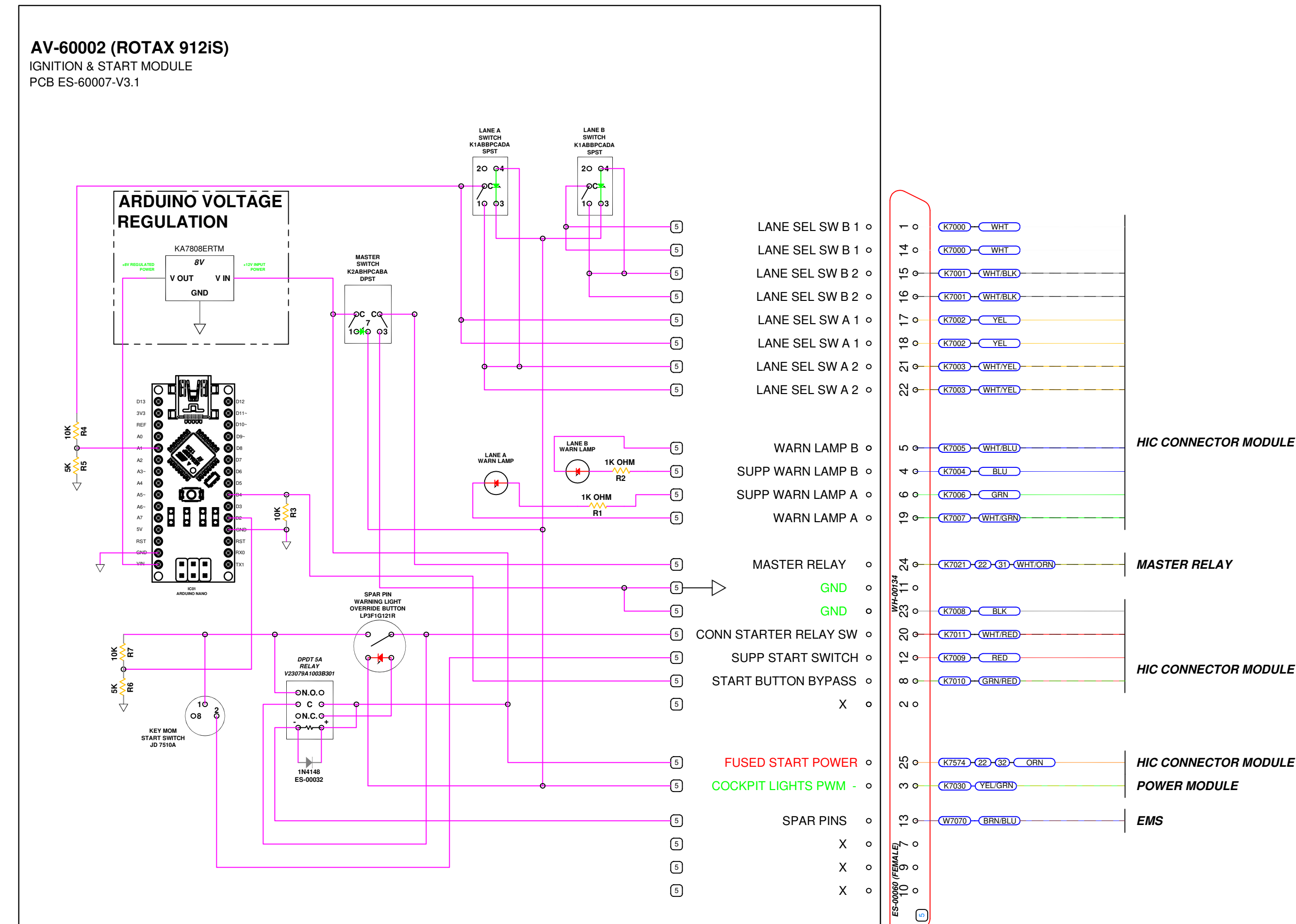

	<b>VAN'S AIRCRAFT, INC.</b>		14401 NE KEIL RD. NI AURORA, OR 97002 USA
	<b>ROTAX 912iS G3X ELECTRICAL SYSTEM</b>		
DATE DRAWN: 6/11/2018	UNITS: <b>INCHES</b>	<b>WH-00134</b>	
DRAWN BY: T. DE MAN TOLERANCES: NONE (UNLESS OTHERWISE SPECIFIED)	SCALE: NONE	PAGE: 10 OF 11	
PATH:FILENAME: Q:\RV-12\System 5\Electrical System 5\Electrical System 912iS G3X (WH-00134).DWG			C-SIZE ORIGINAL

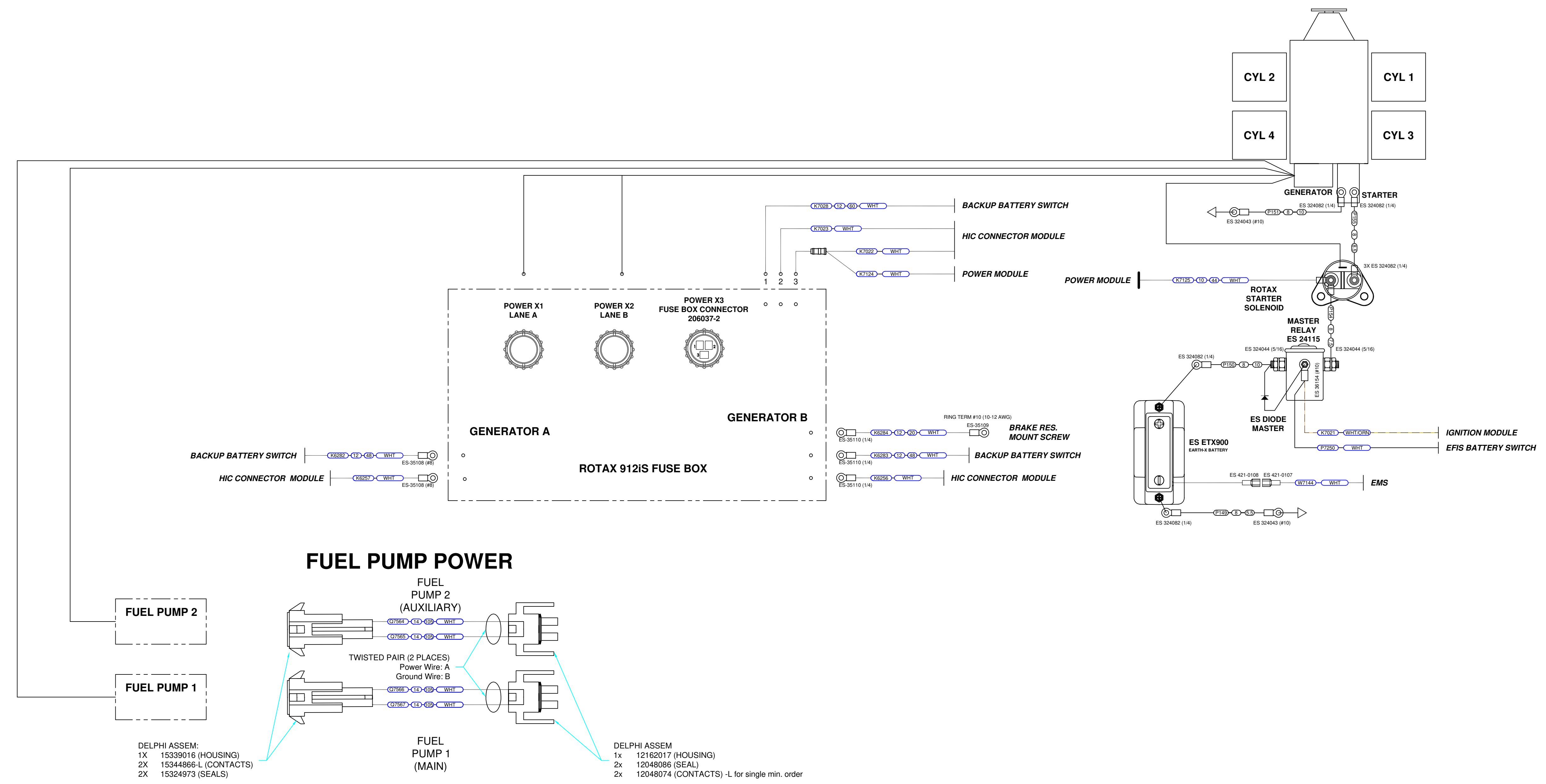

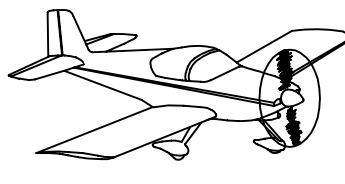
	<b>VAN'S AIRCRAFT, INC.</b>		14401 NE KEIL RD. NE AURORA, OR 97002 USA
	<b>ROTAX 912iS G3X ELECTRICAL SYSTEM</b>		
DATE DRAWN: 6/11/2018	UNITS: <b>INCHES</b>	<b>WH-00134</b>	
DRAWN BY: T. DE MAN TOLERANCES: NONE (UNLESS OTHERWISE SPECIFIED)	SCALE: NONE	PAGE: 11 OF 11	
PATH:FILENAME: Q:\RV-12\System 12\Electrical System 12\Electrical System 912iS G3X (WH-00134).DWG			C-SIZE ORIGINAL