

TOTAL PERFORMANCE VAN'S AIRCRAFT

14401 Keil Road NE, Aurora, Oregon, USA 97002

PHONE 503-678-6545 • FAX 503-678-6560 • www.vansaircraft.com • info@vansaircraft.com

Service Letters and Bulletins: www.vansaircraft.com/public/service.htm

SERVICE BULLETIN 14-02-05

- Date Released:** February 5, 2014
- Date Effective:** February 5, 2014
- Subject:** Cracking in elevator spar web near elevator attach points.
- Affected Models:** All RV-3, 4, 6/6A, 7/7A, 8/8A Flying aircraft
- Required Action:** Inspect for cracks as described in this document. Stop-Drill cracks (if present) then apply E-00001A and E-00001B Hinge Doubler fix as required to cracked elevator hinge positions. RV-3,4 and 6/6A customers will need to fabricate their own doublers using E-00001A and E-00001B as a guideline.
- Time of Compliance:** Inspect before further flight.
- If no cracks are detected, re-inspect at every annual condition inspection or until E-00001A or E-00001B Hinge Doubler repair has been installed.
 - If cracks are detected, the E-00001A and E-00001B Hinge Doubler repair must be installed at the cracked hinge position before further flight.

Supersedes Notice: SB14-02-03

Synopsis:

Cracks have been found near the rivets attaching the nutplates that hold the elevator rod ends to the E-702 Spar and E-610PP or E-611PP Spar Reinforcement Plates. See Figure 1, Figure 2 and corresponding elevator assembly plans pages.

Method of Compliance:

NOTE: Installation of this service bulletin as preventative maintenance is not recommended. If cracking has occurred at an outboard hinge position, install a doubler only at that position.

TOTAL PERFORMANCE VAN'S AIRCRAFT

14401 Keil Road NE, Aurora, Oregon, USA 97002

PHONE 503-678-6545 • FAX 503-678-6560 • www.vansaircraft.com • info@vansaircraft.com

Service Letters and Bulletins: www.vansaircraft.com/public/service.htm

Step 1: Carefully inspect elevator hinge positions around the rivets noted in Figure 2.

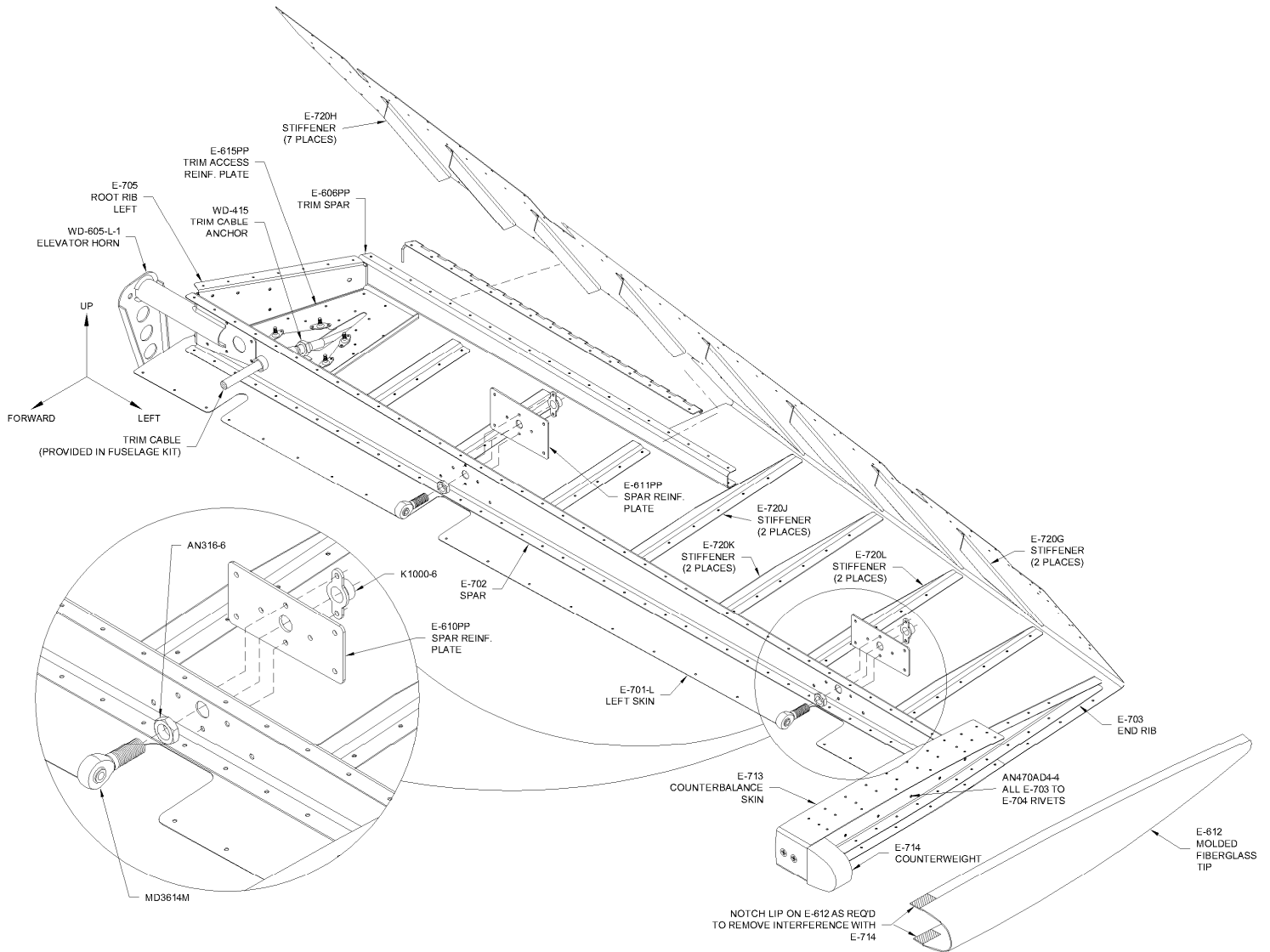

FIGURE 1: ELEVATOR ASSEMBLY

Step 2: If cracking is found, remove the elevator and stop drill #40 the cracks through the E-702 spar web only. Do not continue to drill through the E-610PP or E-611PP Spar Reinf. Plates. See Figure 2.

TOTAL PERFORMANCE VAN'S AIRCRAFT

14401 Keil Road NE, Aurora, Oregon, USA 97002

PHONE 503-678-6545 • FAX 503-678-6560 • www.vansaircraft.com • info@vansaircraft.com

Service Letters and Bulletins: www.vansaircraft.com/public/service.htm

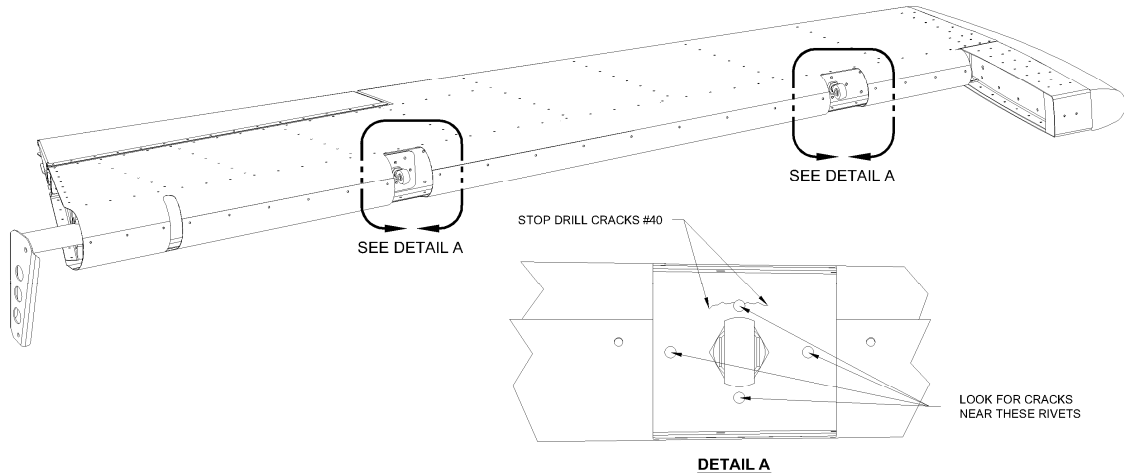

FIGURE 2: INSPECTION FOR CRACKING

Step 3: Cut off the head of a SCREW 3/8-24 X 1 3/4 to make a tool to hold the nutplate in place in the following steps. See Figure 3.

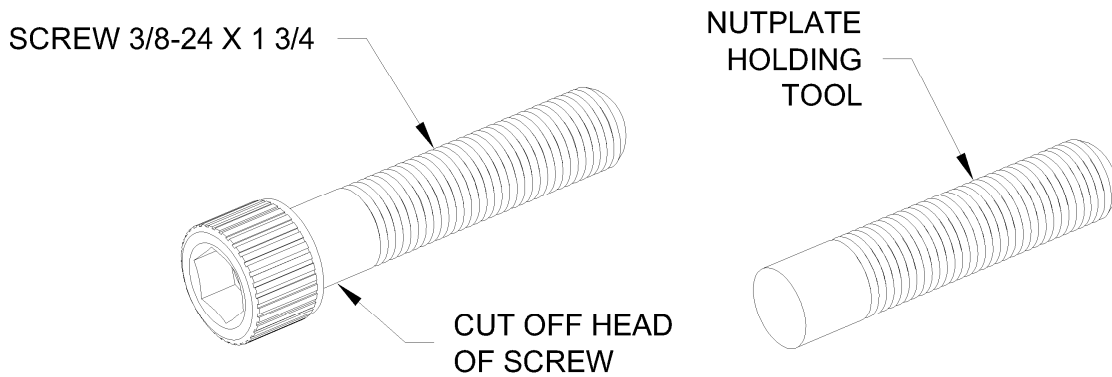

FIGURE 3: NUTPLATE HOLDING TOOL

Step 4: Remove the MD3614M Rod End and AN316-6 Jam Nut. Insert the Nutplate Holding Tool into the nutplate. See Figure 5.

Step 5: Remove the four rivets surrounding the rod end bearing hole (Figure 2). Use the Nutplate Holding Tool to prevent the nutplate from falling inside the elevator. Refer to Section 5 on how to carefully remove rivets without causing rivet hole damage.

Step 6: Separate the E-00001 Hinge Doubler into A and B parts. See Figure 4.

Radius the top and bottom edges of the E-0001A Outboard Hinge Doublers that will nest against the corresponding radius in the spar.

NOTE (If repairing an older non-pre punched kit): Use AS3-063 to fabricate doublers. Use the supplied doublers as templates for making the new doublers. Leave out the four hole locations where rivets were removed in Step 5. Position the doubler over the nutplate holding tool and match drill the elevator spar and E-610PP or E-611PP Spar Reinf. Plates at the four corner rivet hole locations. Cleco as you drill each hole. Uncleco the doubler as required then use a hole finder/locator tool to match drill the four original holes into the new doubler while the doubler is clecoed in place.

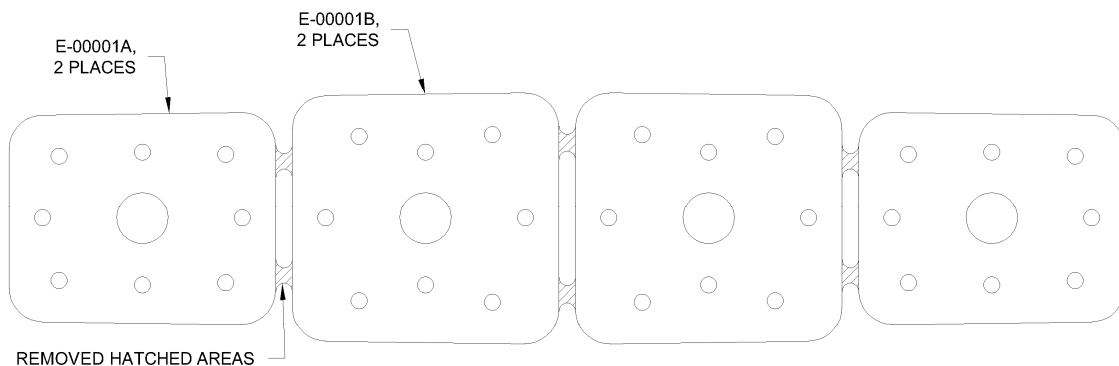

FIGURE 4: SEPARATING THE HINGE DOUBLER

Step 7: Final-Drill #30 the holes in the doublers that are common to the holes in the spar for rivets that were removed in Step 5.

Step 8: Slip either the E-00001A Outboard Hinge Doubler or E-00001B Inbd Hinge Doubler as required for the hinge position over the Nutplate Holding Tool.

Step 9: Cleco the doubler to the Elevator Assembly using the inboard and outboard most holes common between the doubler and open holes from Step 4. See Figure 5.

Match-Drill #30 the four corner holes in the doubler into the E-702 Spar and the E-610PP or E-611PP Spar Reinf. Plate. Use a sharp drill bit and light pressure to minimize the burr on the back side.

Step 10: Remove and deburr the doubler and the new holes in the elevator assembly. Prime the doubler if desired.

TOTAL PERFORMANCE VAN'S AIRCRAFT

14401 Keil Road NE, Aurora, Oregon, USA 97002

PHONE 503-678-6545 • FAX 503-678-6560 • www.vansaircraft.com • info@vansaircraft.com

Service Letters and Bulletins: www.vansaircraft.com/public/service.htm

Step 11: Cleco then rivet the doubler to the Elevator Assembly using the rivets called out in Figure 5 (Be certain to reattach the nutplate when installing rivets in its associated holes).

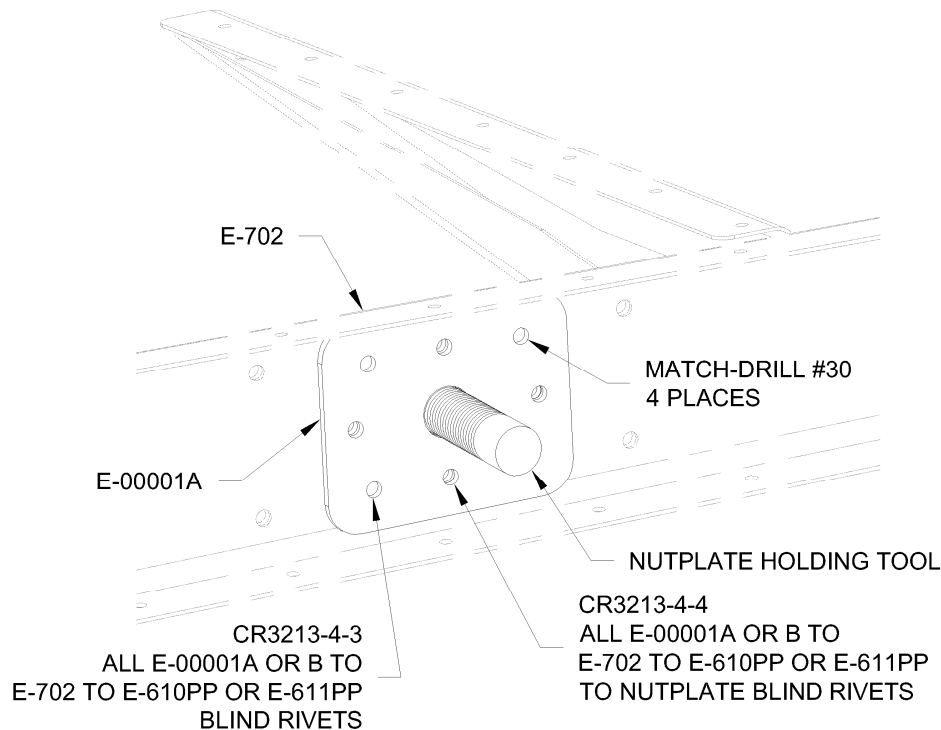

FIGURE 5: ADDING THE DOUBLER PLATE
(SKIN NOT SHOWN FOR CLARITY)

Step 12: Remove the Nutplate Holding Tool and reinstall the MD3614M Rod End and AN316-6 Jam Nut.

NOTE: Misalignment of a rod end relative to the overall hinge line of the elevator can contribute to cracking near the misaligned rod end. If a distance greater than 13/16 is required at the outer rod end contact Van's Aircraft for further instruction.

Step 13: Adjust the outboard rod end distance to 3/4 inch from the center of the rod end to the forward face of the E-00001A Outboard Hinge Doubler (this should be the previous position of the rod end relative to the spar).

TOTAL PERFORMANCE VAN'S AIRCRAFT

14401 Keil Road NE, Aurora, Oregon, USA 97002

PHONE 503-678-6545 • FAX 503-678-6560 • www.vansaircraft.com • info@vansaircraft.com

Service Letters and Bulletins: www.vansaircraft.com/public/service.htm

If the rod end bottoms out before reaching the 3/4 inch dimension, adjust the outboard rod end to a distance of 13/16 from the center of the rod end ball to the forward face of the doubler. This will cause the outboard end of the elevator to be swept back very slightly. This change is insignificant.

Step 14: Adjust the center rod end so that it is aligned/centered between the hole in the WD-605-L/R-1 Elevator Horn and the outboard rod end. To check the alignment, place a white piece of paper outboard of the outboard rod end. Shine a bright light on the paper (works best in a dimly lit room). Sight by eye through the 1/4 inch hinge point hole in the elevator horn and verify that the inboard rod end is centered relative to the hole in the elevator horn and the outboard rod end (the balls in both rod ends need to be positioned as they would be when bolted to the stabilizer). If it is not properly centered, adjust only the inboard rod end as needed.

If the center rod end bottoms out before alignment is achieved, a special rod end will be required at the outboard attach point. Contact Van's Aircraft for further assistance.

Step 15: Once the hinge line is straight tighten all jam nuts to secure the rod ends in place.

Remount the elevator(s) to the aircraft per the instructions that came with your kit.

Step 16: If applicable, trim the lower aft corner of the WD-605-Elevator Horn as shown in Figure 6. Deburr and prime the trimmed edge.

Check that the elevator travel is within the limits given for your aircraft.

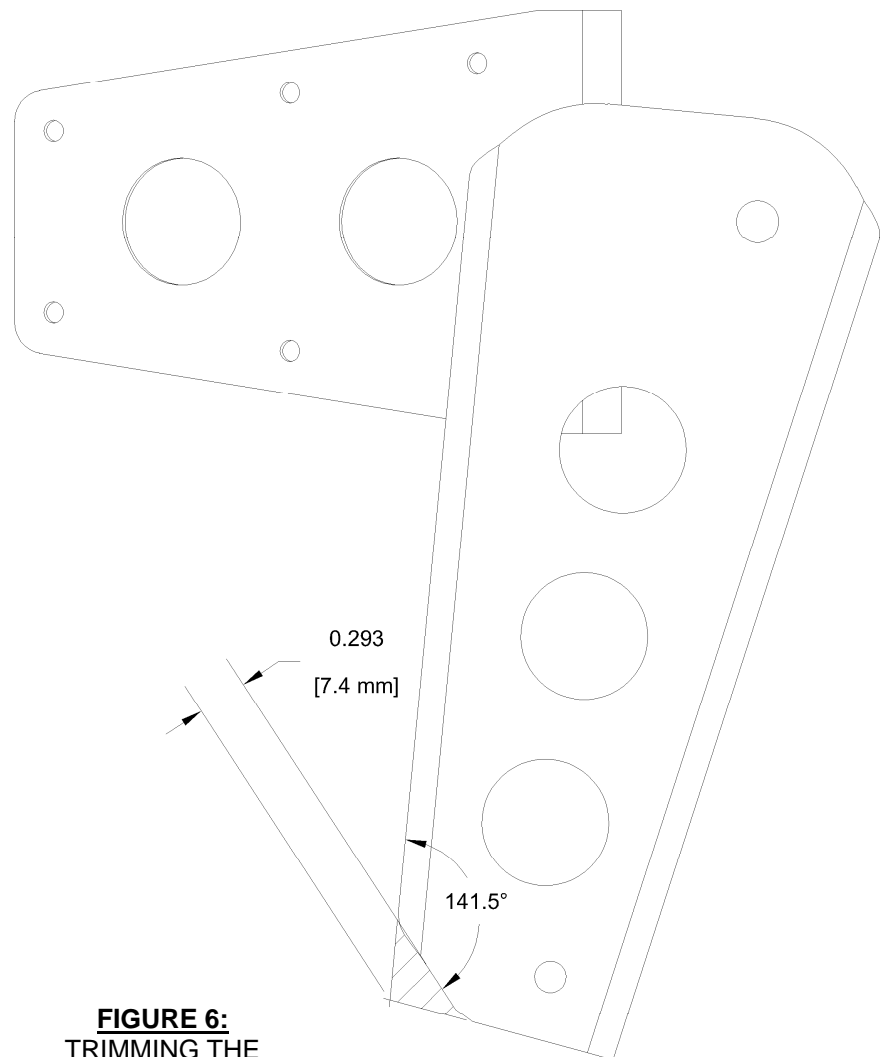

FIGURE 6:
TRIMMING THE
ELEVATOR
HORNS

TOTAL PERFORMANCE
VAN'S AIRCRAFT

14401 Keil Road NE, Aurora, Oregon, USA 97002

PHONE 503-678-6545 • FAX 503-678-6560 • www.vansaircraft.com • info@vansaircraft.com

Service Letters and Bulletins: www.vansaircraft.com/public/service.htm

Step 17: Make a logbook entry indicating compliance with this service bulletin.

TOTAL PERFORMANCE
VAN'S AIRCRAFT

14401 Keil Road NE, Aurora, Oregon, USA 97002

PHONE 503-678-6545 • FAX 503-678-6560 • www.vansaircraft.com • info@vansaircraft.com

Service Letters and Bulletins: www.vansaircraft.com/public/service.htm

Note: Repair Kits can be obtained from Van's Aircraft.

Order:

SB 14-02-05-1 -1 indicates the number of doublers to be installed

SB 14-02-05-2 for 2 doublers to be installed

SB 14-02-05-3 for 3 doublers to be installed

SB 14-02-05-4 for 4 doublers to be installed

Important!

Order the appropriate Repair Kit from the list above based on the number of doublers to be installed.

Parts list: (Single doubler Repair Kit)

Qty

1	E-00001
1	SCREW 3/8-24 X 1 3/4
6	CR3213-4-3 (6 per hinge point)
2	CR3213-4-4 (2 per hinge point)

Note: the number of CR3213 rivets will be adjusted automatically depending on which Repair Kit is ordered. Quantities for the remainder of the parts remain the same in all Repair Kits.