

Page: 42K-ALL REV 0: New section made to document SL-40 installation, installation of associated brackets and installation of an optional data wire.

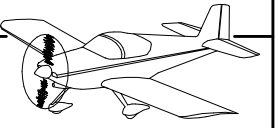

SECTION 42K: SL-40 COM

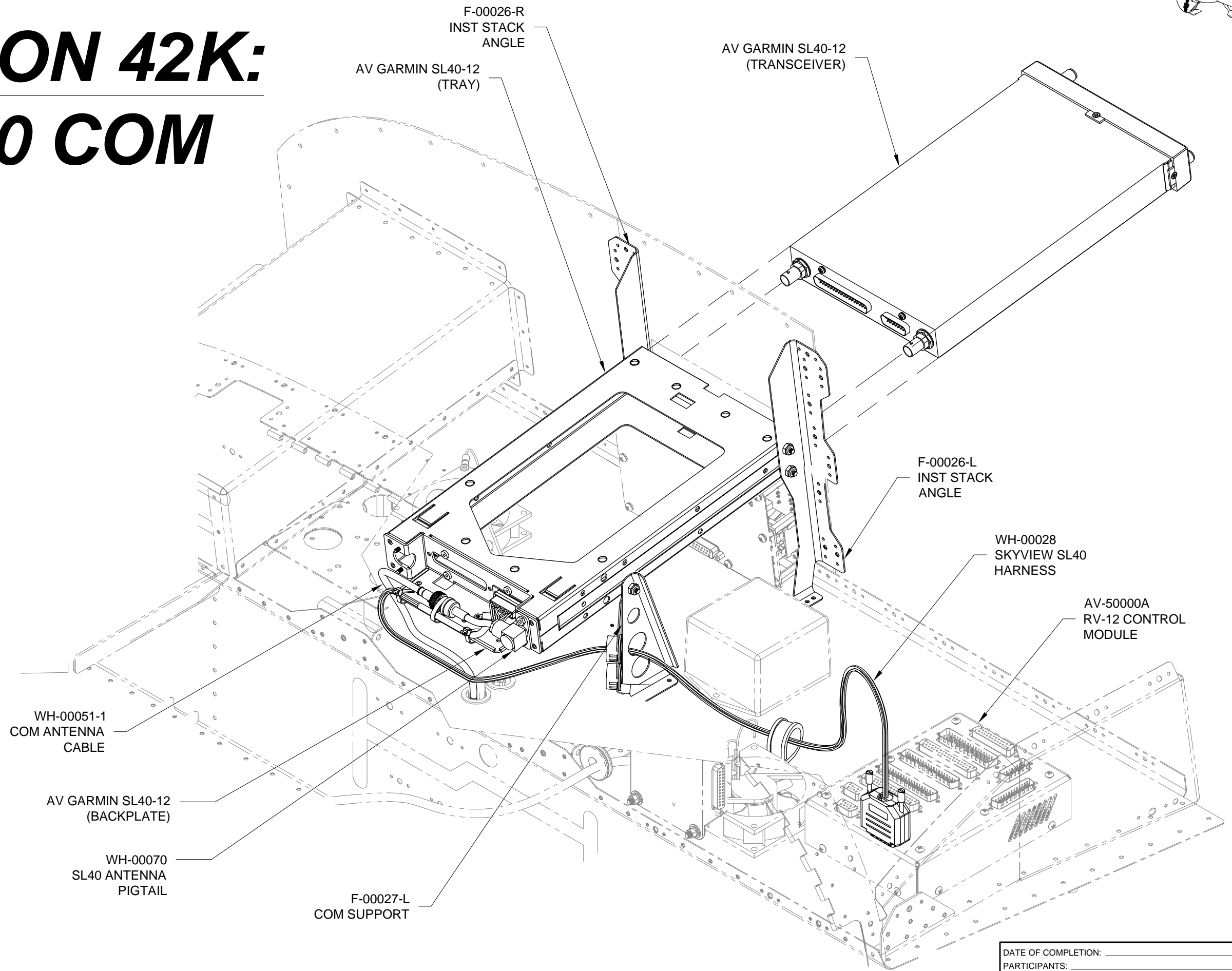

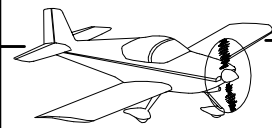

Step 1: Separate the F-00026 Inst Stack Angles into F00026-L & -R.

Machine countersink all the .098 diameter nutplate attach holes in both angles.

Rivet nutplates to the flanges of the angles that will attach to the instrument panel in all but the locations noted in Figure 1.

Rivet the angles to the F-1202B Panel Base as shown in Figure 1.

Step 2: Rivet the F-00027-L & -R Com Supports to the F-1202B Panel Base as shown in Figure 1.

Insert snap bushings into the supports as shown in Figure 1.

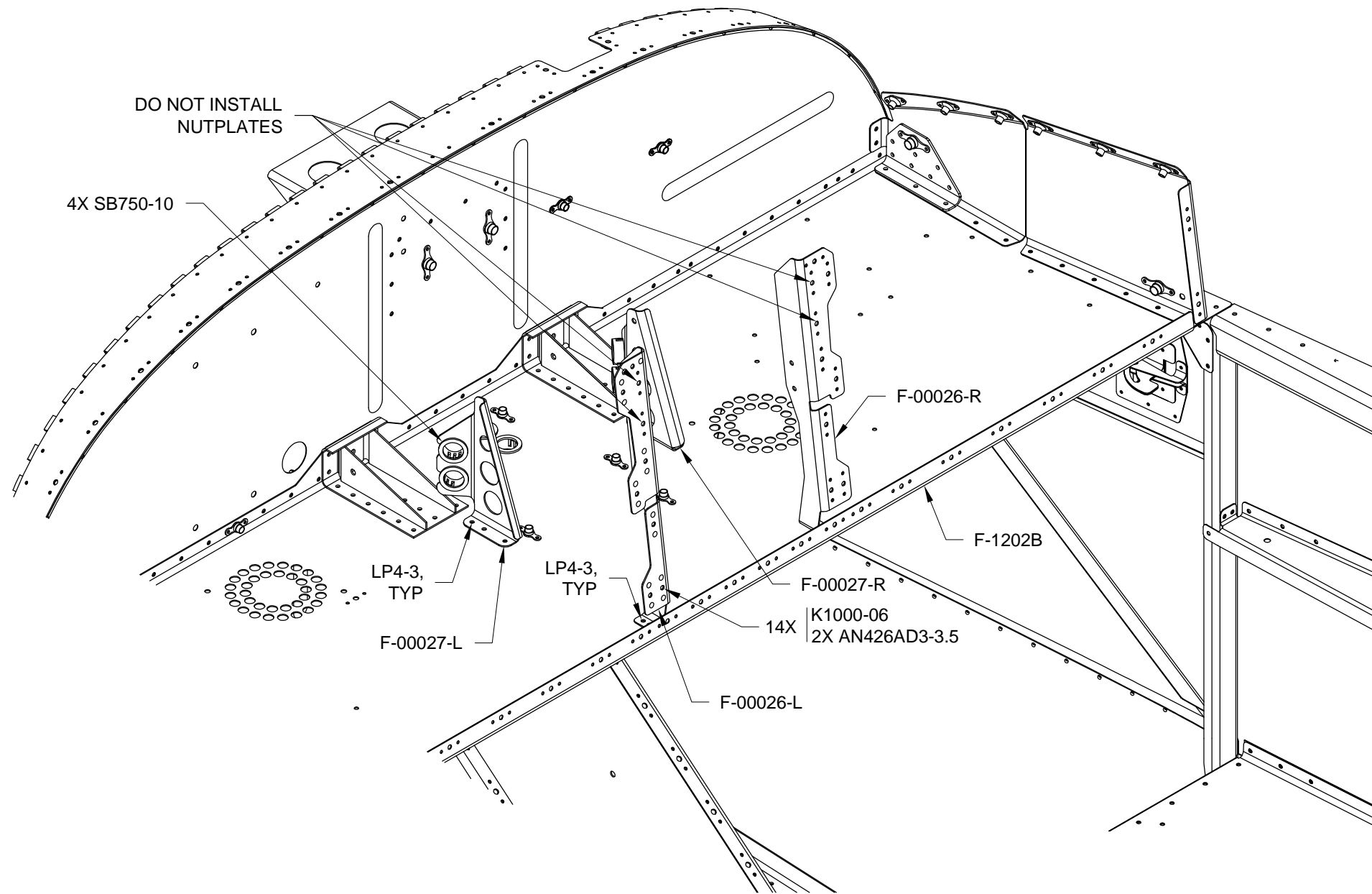
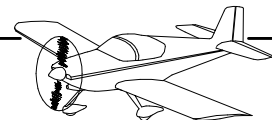

FIGURE 1: INSTALLING THE SUPPORT BRACKETS



Step 1: The WH-00028 SkyView SL40 Harness is supplied already attached to the back of the AV GARMIN SL40-12 Com Radio backplate. Route the SkyView SL40 harness through the upper snap bushing in F-00027-L Com Support and Cushioned Clamp near the left ES CPU FAN as shown in Figure 1.

NOTE: The end of the harness connecting to the AV GARMIN SL40-12 Com Radio Backplate does not use a backshell.

The WH-00051 Com Antenna Cable is configured differently from the WH-00051-1 Comm Antenna Cable. The WH-00051 has a DE 4205-018-N995 90° Connector as shown in Figure 2

Step 2: Connect the WH-00028 SkyView SL40 Harness labeled 'NAV/COM' to the AV-50000A RV-12 Control Module. See Figure 1.

If applicable, Install and secure the WH-00051-1 with a PLASTIC TIE-WRAP 4" as shown in Figure 2. Remove and return the WH-00070 SL40 Antenna Pigtail to Van's Aircraft.

Otherwise, delay installation of WH-00051-1 until Step 4.

Step 3: Install the WH-00070 SL40 Antenna Pigtail to the back of the AV GARMIN SL40-12 Com Radio tray as shown in Figure 2. See the instructions included with the SL40-12 if needed (This step may have already been completed).

Step 4: Attach the WH-00051-1 Com Antenna Cable to the WH-00070 SL40 Antenna Pigtail. Secure the connector with a PLASTIC TIE WRAP 4" as shown in Figure 1.

Step 5: Attach the AV GARMIN SL40-12 Com Radio Tray to the F-00026-L & -R Inst Stack Angles and the F-00027-L & -R Com Supports as shown in Figure 1.

Step 6: Install the AV GARMIN SL40-12 Com Radio into its tray.

Step 7: Install a ES-00205 Lighted 5 Amp Blade Fuse into the "COM" position of the AV-50001 Power & Switch Module.

Install a second fuse of the same type into the fuse holder. Mark out the previous value on the fuse holder label if different than 5 amps and re-write the value to "5".

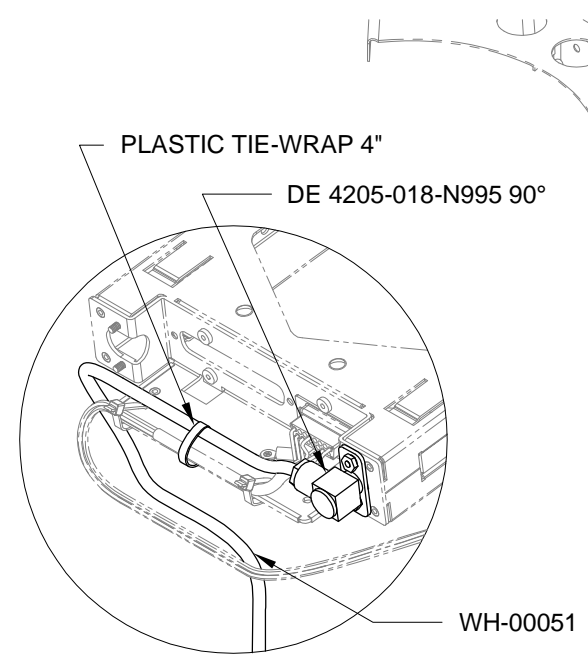
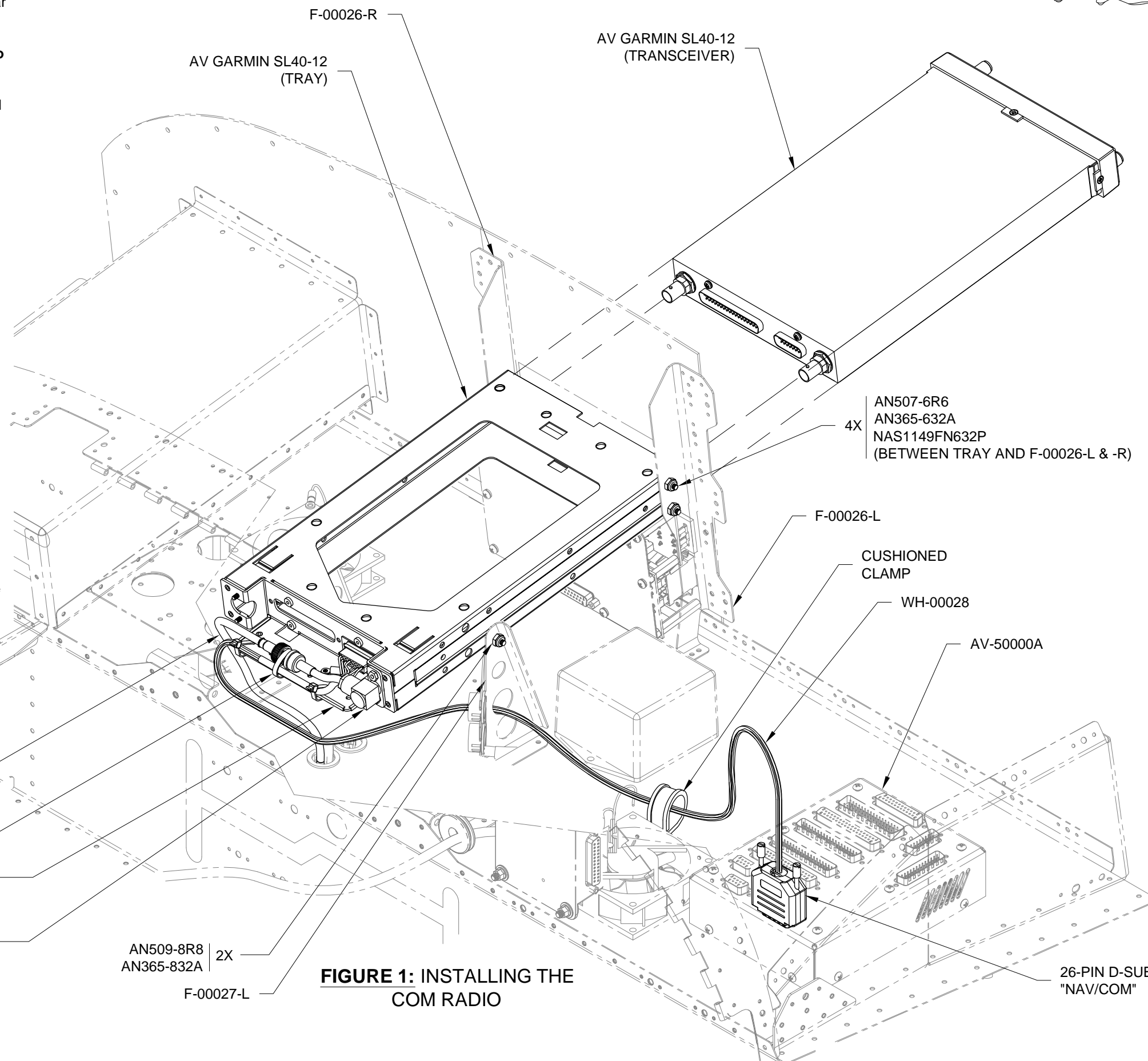
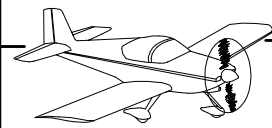

FIGURE 2: WH-00051 INSTALLATION

FIGURE 1: INSTALLING THE COM RADIO



NOTE: As an option a data return line WH-F1102 Data Wire may be added to the SL-40. This allows the status of the SL-40 to be displayed on the SkyView EFIS.

Step 1: One end of the WH-F1102 Data Wire has a ring terminal. Insert the d-sub connector closest to the ring terminal into the 25-pin d-sub connector connected to the AV GARMIN SL40-12 tray at the location shown in Figure 1.

Remove the screw shown in Figure 2 and lock washer (if installed) that retains the existing ring terminal from the to the WH-00028 SkyView SL40 Harness to the back of the tray. Slip the lock washer (if not installed use blue Loctite), harness ring terminal and the terminal on the data wire over the screw then re-install. If the screw supplied is too short order a longer screw from Van's Aircraft per the callout in Figure 2.

Step 2: Remove the WH-00028 SkyView SL40 Harnesses connector labeled 'NAV/COM' from the AV-50000A RV-12 Control Module. See Figure 1.

Remove the backshell.

Insert the remaining d-sub connector on the WH-F1102 Data Wire into the 15-pin d-sub connector at the location shown in Figure 1.

Re-install the backshell.

Step 3: Enter the SkyView setup menu then LOCAL DISPLAY SETUP > SERIAL PORT SETUP > SERIAL PORT 4 SETUP then from the menu select "GARMIN / APOLLO SL40".

To display the status of the SL-40 on the EFIS enter the setup menu then SYSTEM SETUP > DISPLAYED COM then select "GARMIN / APOLLO SL40".

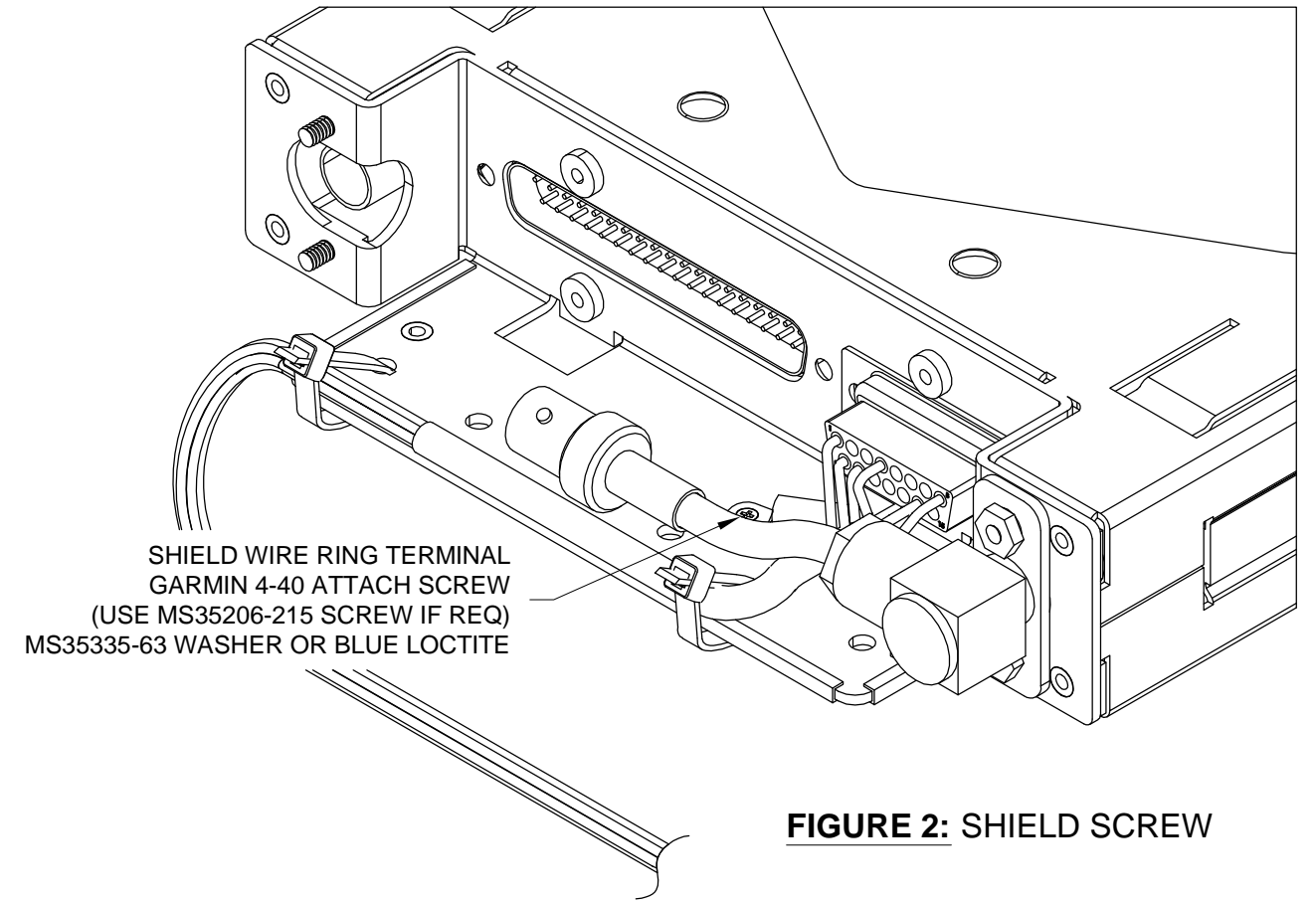
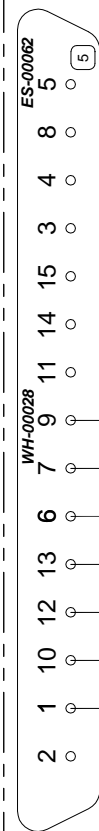

FIGURE 2: SHIELD SCREW

NAV/COM

- PANEL LIGHTS - 5 ○
- AUDIO GND 8 ○
- COMMON 4 ○
- NAV AUDIO 3 ○
- AUDIO COM 2 15 ○
- AUDIO MIC COM 2 14 ○
- TX KEY COM 2 11 ○
- GND 9 ○
- NAV/COM DATA A 7 ○
- NAV/COM DATA 2A 6 ○
- AUDIO COM 1 13 ○
- AUDIO MIC COM 1 12 ○
- TX KEY COM 1 10 ○
- COM POWER 1 ○
- COM POWER 2 ○



GARMIN SL-40

RADIO SL40

- 1 AVIONICS POWER
- 2 X
- 3 RS232 TX
- 4 TX KEY
- 5 X
- 6 SPEAKER
- 7 MIC GND
- 8 AUDIO IN 1 (MIC)
- 9 AVIONICS GND
- 10 RS232 RX
- 11 RS232 GND
- 12 INTERCOM
- 13 AUDIO GND
- 14 AUDIO OUT
- 15 AUDIO IN MIC 2

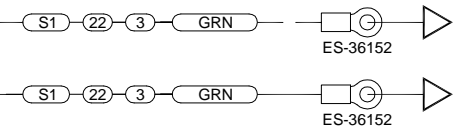

FIGURE 1: OPTIONAL DATA LINE