

VAN'S AIRCRAFT

TOTAL PERFORMANCE

14401 Keil Road NE, Aurora, Oregon, USA 97002

PHONE 503-678-6545 • FAX 503-678-6560 • www.vansaircraft.com • info@vansaircraft.com

Service Letters and Bulletins: www.vansaircraft.com/public/service.htm

NOTIFICATION 17-12-08

Date Released: December 8th, 2017

Date Effective: December 8th, 2017

Subject: Canopy Latch/Handle Upgrade

Affected Models: All RV-12 Aircraft

Required Action: Replace old handle and latch block components with revised components.

Time of Compliance: None - Optional

Supersedes Notice: N 16-10-03

Labor Required / SLSA Warranty Allowance: Not Applicable

Level of Certification: (Owner, LSA Repairman Inspection - *not applicable to SLSA*), LSA Repairman Maintenance, A&P

Synopsis:

A new canopy handle designed for the RV-12iS fuselage is now available for retrofit into older RV-12 aircraft or kits shipped prior to January 2018. **Note:** This Notification assumes that the airplane has already incorporated the N 16-20-03 and N 14-05-22 parts, or installed those parts in the initial build.

Method of Compliance:

Step 1: See KAI Section 24 and Section 34.

Remove and discard the following: C-656 Canopy Handle, C-1215 Latch Handle Stop, C-1205-1 Latch Block, F-1231F-1 Latch Plate Arm, C-1214 Latch Block, F-1231G Canopy Catch and the WD-1218 Canopy Latch.

Remove and set aside the canopy latch micro-switch and associated hardware.

Step 2: Install the C-1215-1 Latch Handle Stop as shown in Figure 1. If installing the canopy handle for the first time use the dimensions to position and match-drill #30 the latch handle stop to the WD-1219 Canopy Frame.

Step 3: Drill a pilot hole in the end of the C-656 Canopy Handle as shown in Figure 2. Be sure to drill perpendicular to the face of the Canopy Handle.

Assemble the WD-01218-1 Canopy Latch and C-656 Canopy Handle as shown in Figure 3. The tube end of the canopy latch may be shortened if/as required to achieve the dimension called out in Figure 3.

Using the pilot hole in the canopy handle as a drill guide, match-drill #30 through both sides of the canopy latch tube and into the canopy handle to the depth called out in Figure 3.

Disassemble the canopy latch and canopy handle. Final-Drill #19 through the front part of the canopy handle. Cut threads in the rear "tail" portion of the canopy handle using an 8-32 tap. Machine countersink the canopy handle to fit the head of a #8 flush screw.

Final-Drill #19 through the canopy latch. Deburr holes.

Round off the edges of the latch plate as shown in Figure 3 Sections A-A and B-B. The canopy handle edges and ends may be rounded if/as desired. See Figure 3 for an example of a final shape.

Step 4: Chamfer the inside of BUSHING-AL.509X.625X.281 allowing it to sit lower on the WD-01218-1 Canopy Latch tube as shown in Figure 4.

Step 5: Install the WD-01218-1 Canopy Latch, called out bushing, C-671 Plastic Washer and C-656 Canopy Handle on the WD-1219 Canopy Frame as shown in Figure 4.

If the canopy latch rotates freely enough in the canopy frame tube that it will turn under its own weight when the canopy is rotated up to the open position, then the bottom of the canopy frame tube should be carefully pinched slightly with a clamp so as to create enough friction to prevent undesired rotation.

When installing the canopy latch for the final time, lightly grease the pivot tube so as to prevent corrosion and to help keep water out.

Step 6: Machine countersink C-01213A for the heads of the rivets called out in the detail view in Figure 5.

Step 7: Remove the previously installed rivets and then machine countersink the five holes on the forward face of the Roll Bar Assembly indicated in the detailed view of Figure 5.

Step 8: Cleco the F-01231F-2 to the Roll Bar Assembly. Match-Drill #43 the switch mounting hole of the F-01231F-2 into the Roll Bar Assembly. See the detail view in Figure 5.

Remove the F-01231F-2. Final-Drill #30 the hole just created in the Roll Bar Assembly.

Step 9: Deburr the F-01231F-2 and tap #4-40 the switch mounting hole in the F-01231F-2 only.

Step 10: Rivet C-01213A and C-01213B to the Roll Bar Assembly. See Figure 5.

Step 11: Fill the open holes on the front and back sides of the roll bar frame as called out in Figure 5.

Step 12: Study Figure 6. For retrofit installations the two flush rivets near the roll bar centerline will already be installed (see Steps 13 and 14) for initial installations they will not (See Steps 15 and 16).

Step 13 (Retrofit only): In Figure 6 there are callouts for three flush rivets. The two near the centerline are already installed. The third outboard rivet is currently a domed head rivet. Remove this rivet, machine countersink the hole and install a flush rivet per the callout in Figure 6.

Step 14 (Retrofit only): Temporarily install C-01205-2 as shown in Figure 7 using the two fasteners near the aircraft centerline. Use the third outboard hole (corresponds to the hole marked Match Drill

on Fig. 6) in C-01205-2 as a drill guide to mark the hole center by using a #19 drill. Turn the drill slowly and only enough to make a small center point. **DO NOT fully drill the hole.** Remove the C-01205-2. Final-Drill #30 and tap #8-32 the drill mark.

Step 15 (Initial Installation only): Cleco the C-01205A Canopy Block Drill Template onto the bottom of the Roll Bar Assembly as shown in Figure 6. Match-Drill #30 the indicated hole of the C-01205A into the Roll Bar Assembly. Be sure to drill perpendicular to the surface. Remove the C-01205A and deburr the hole.

Machine countersink and then rivet the three holes in the Roll Bar Assembly for the flush head rivets called-out in Figure 6.

Step 16 (Initial Installation only): Tap #8-32 the three holes in the Roll Bar Assembly for the screws shown in Figure 7. The C-01205-2 can be used to help keep the tap square to the bottom surface of the Roll Bar assembly: Insert the tap through one of the two holes in the thicker portion of the C-01205-2, center the end of the tap on the hole in the Roll Bar Assembly, slide and hold the C-01205-2 flush against the bottom of the Roll Bar Assembly, then tap the hole. Repeat for the remaining two holes.

Step 17: Machine countersink the C-01205-2 for the heads of the screws, then install it with the hardware shown in Figure 7. Do not install the two C-01205B's. They are installed in later steps if necessary, and are shown here for reference purposes only.

NOTE: Complete Steps 18-21 if a seal kit is installed. If you wish to install the seal kit, order the 12 CANOPY SEAL KIT.

Step 18 (Seal Kit Installed): If a seal kit is installed remove and modify the C-1221-L & -R Seal Retainers as shown in Figure 10 to provide clearance between the retainers and the canopy block. Deburr and bevel the edges at the screw slots as shown in Figure 10, if desired, which aids in sliding the retainer beneath the washers.

Step 19 (Seal Kit Installed): Trim the C-1220-L/R Roll Bar Seals to match the modified C-1221-L & R Seal Retainers. See Figure 12 and Figure 13.

Step 20 (Seal Kit Installed): Fabricate the C-01224 Latch Seal from SEAL-00003 Foam PVC .375X.625 per Figure 11. Add relief notches for the canopy fasteners and canopy handle tube as shown in Figure 12.

Step 21 (Seal Kit Installed): Close the canopy. Looking straight down, place a piece of tape aligned with the forward edge of the canopy latch block. See Figure 13 and Figure 14.

Open the canopy and use the edge of the tape to position the C-01224 as shown in Figure 12. Remove the adhesive backing attach C-01224 to the canopy frame assembly.

Step 22: From inside the cockpit lower the canopy and rotate the latch to the closed position.

If there is any gap between the top surface of the latch plate and the lower surface of the guide block that allows canopy movement when you pull down firmly on the handle (even though the latch is fully closed and the latch pin contacts the stop) remove the guide block and add one or two C-01205B Shims between guide block and roll bar to lower the block and eliminate the gap. See Figure 8.

It is acceptable for the latch plate to strike the ramped portion of the block. See Figure 8. If the latch action is difficult adjust or trim the canopy seals to correct the latch action. If the handle needs to move downwards to improve the latching action replace the C-671 Plastic Washer and BUSHING-AL.509X.625X.281 installed in Steps 4 and 5 with the C-01223 Canopy Latch Spacer and

BUSHING-AL.509X.625X.344 (modify the bushing per Step 4 before installation). Only as a last resort change the F-01205B spacers. Changing the spacers will commonly only mask problems that should be corrected with the canopy seals or the canopy handle.

Step 23: Install the micro switch on the F-01231F-2 Latch Plate as shown in Figure 9. Insert the screws into the micro switch mounting holes and thread on the two lock nuts. Orient the lock nuts so that the flanges will contact the latch plate. **DO NOT** apply more than 3 in-lb beyond prevailing torque to the two lock nuts against the switch.

While keeping the end of the lower screw in the kidney-shaped slot, thread the end of the upper screw into the tapped switch mounting hole in the latch plate until the lock nut flanges contact the latch plate. Loosely install the washer and lock nut on the lower screw.

Step 24: Close the canopy and latch it shut. Rotate the micro switch about the upper screw. Align the micro switch so that the switch is only activated (indicated by a small clicking sound) when the latch is fully latched.

Secure the micro switch by tightening the lock nut against the washer on the forward side of the latch plate. See Detail A in Figure 9.

Step 25: Make a logbook entry indicating compliance with N 17-12-08.

Place a copy of this notification in the back of the maintenance manual for your aircraft. Note the addition of this notification to the bottom of the Maintenance Manual table of contents.

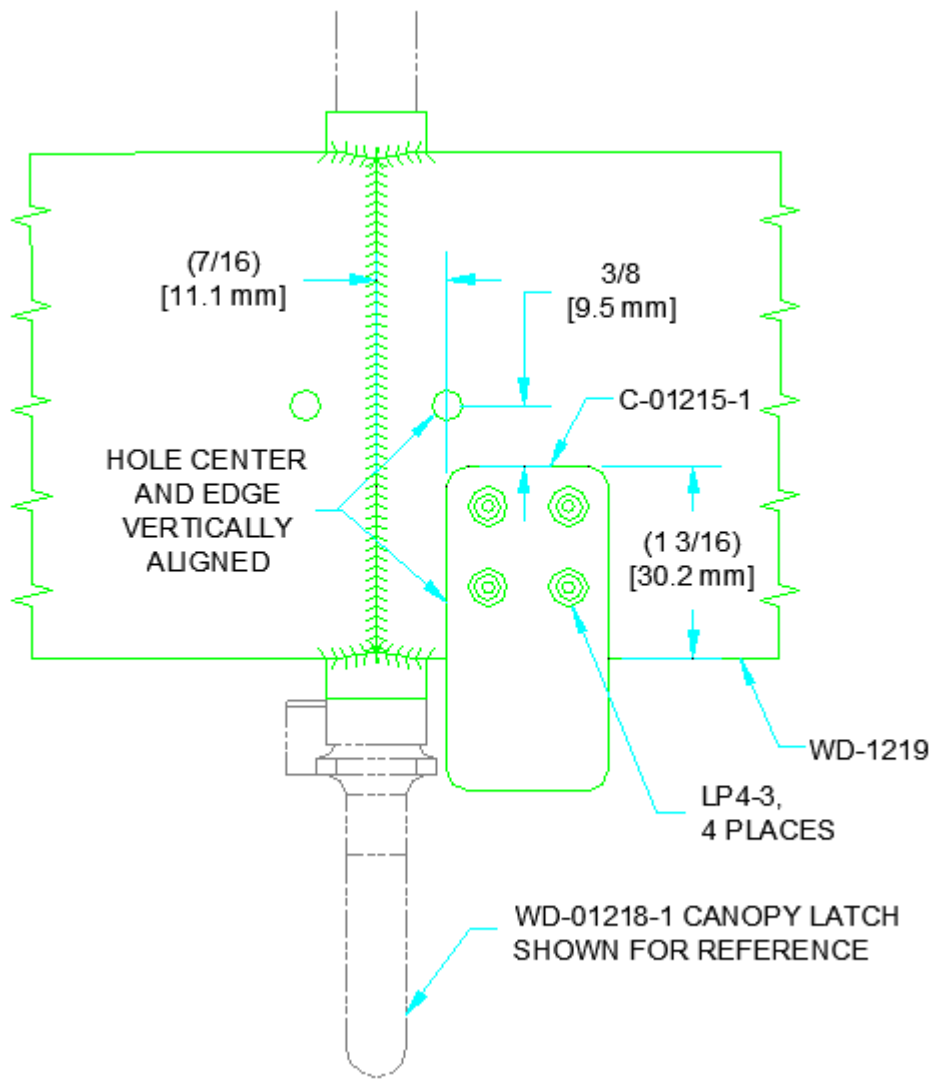

FIGURE 1: ADDING C-01215-1

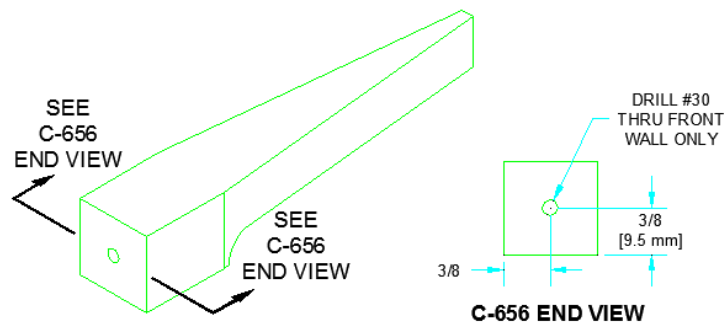

FIGURE 2: PILOT DRILL CANOPY HANDLE

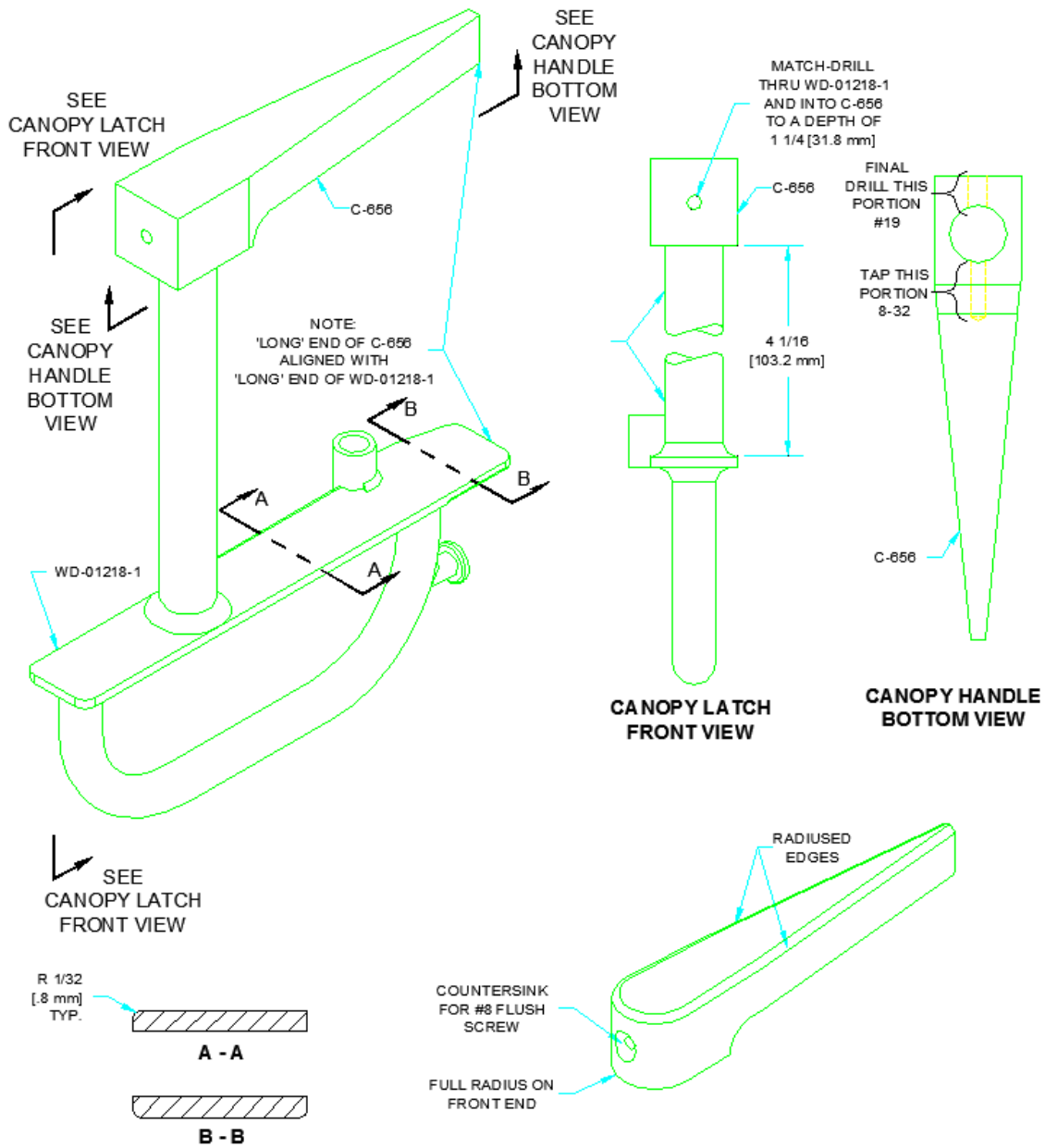
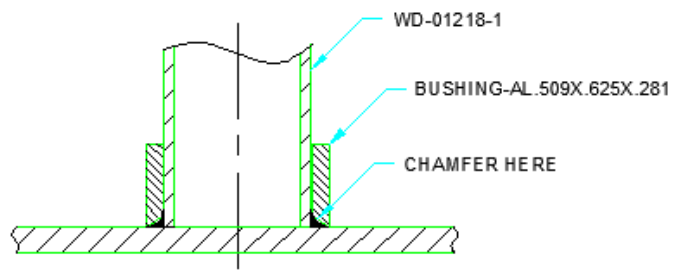

FIGURE 3: CANOPY HANDLE ASSEMBLY



DETAIL D
CHAMFER BUSHING

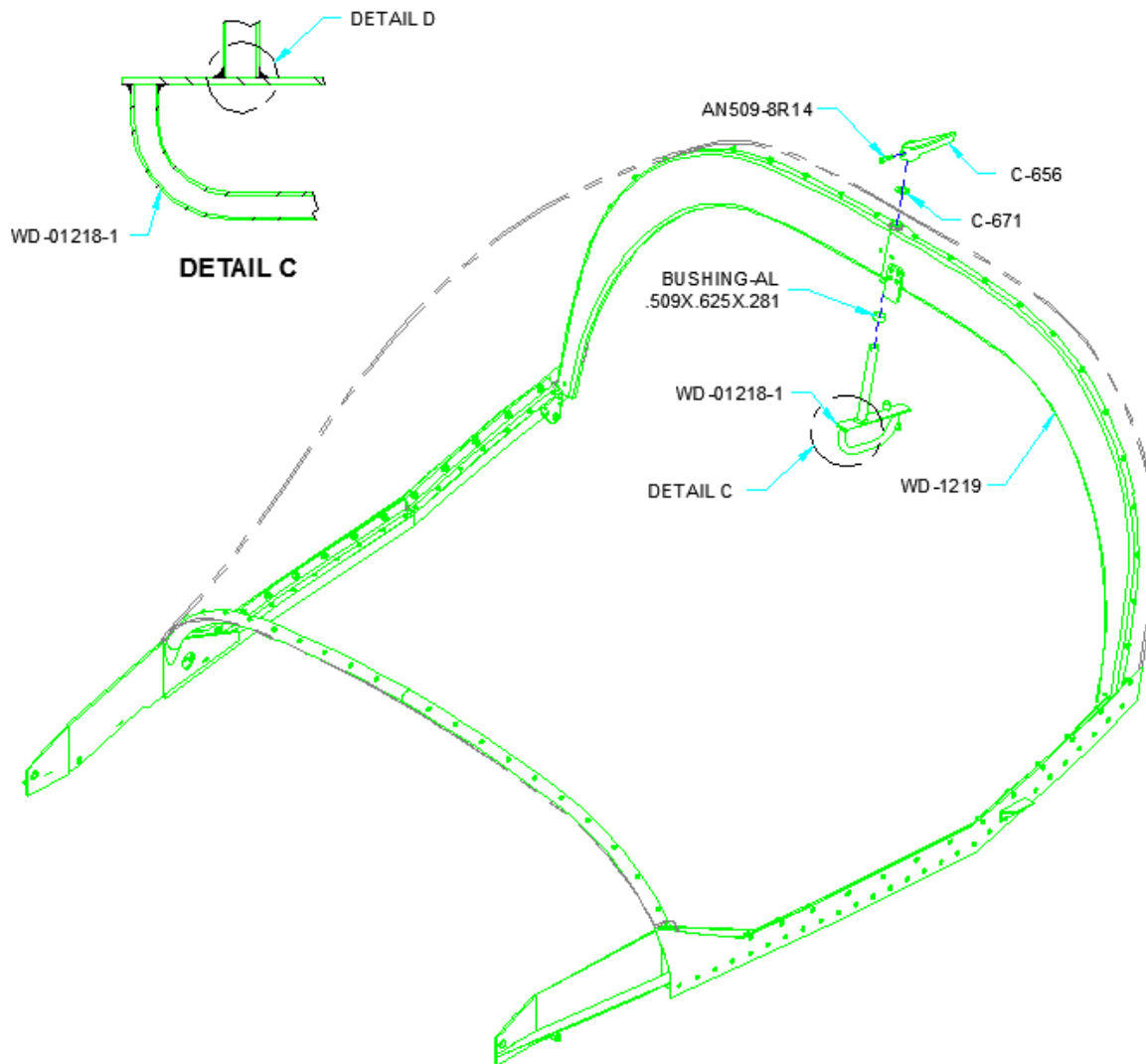

FIGURE 4: CANOPY LATCH INSTALLATION

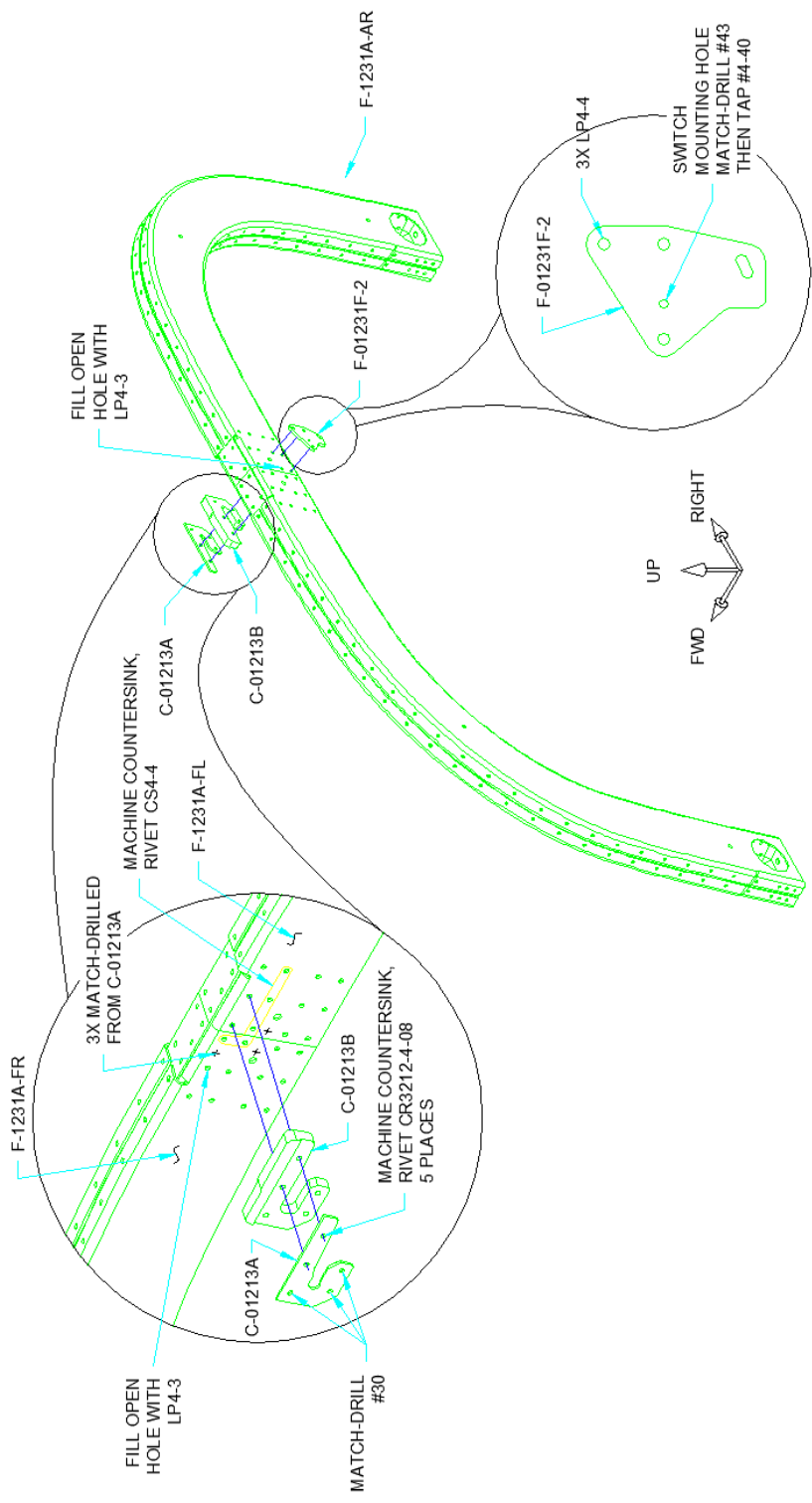

FIGURE 5: ROLL BAR UPDATE

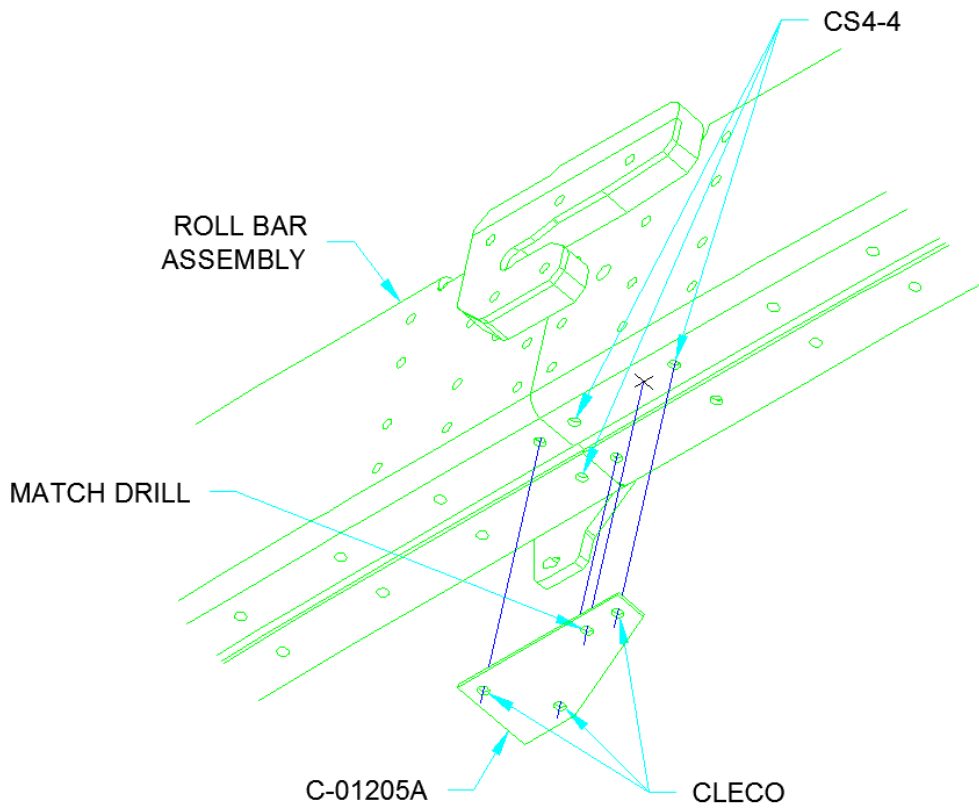

FIGURE 6: DRILLING FOR THE CANOPY LATCH BLOCK

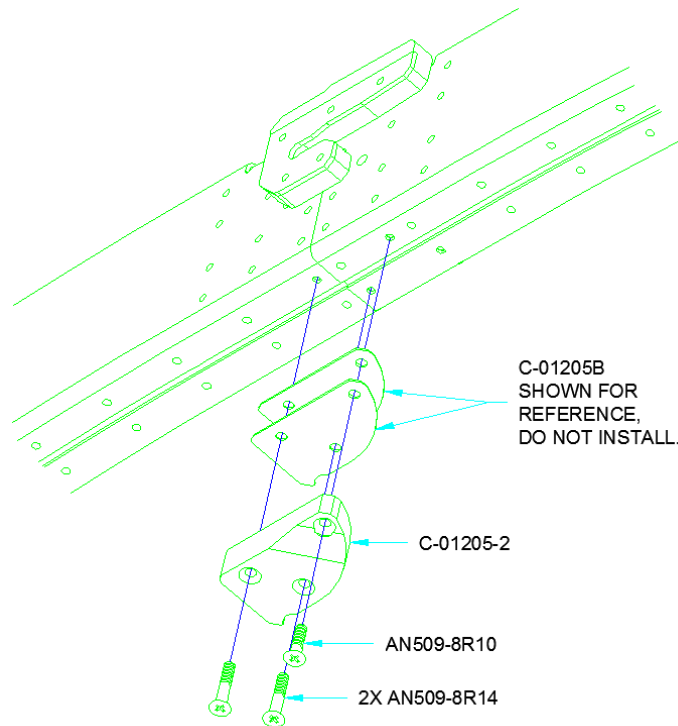

FIGURE 7: C-01205B-2 INSTALL

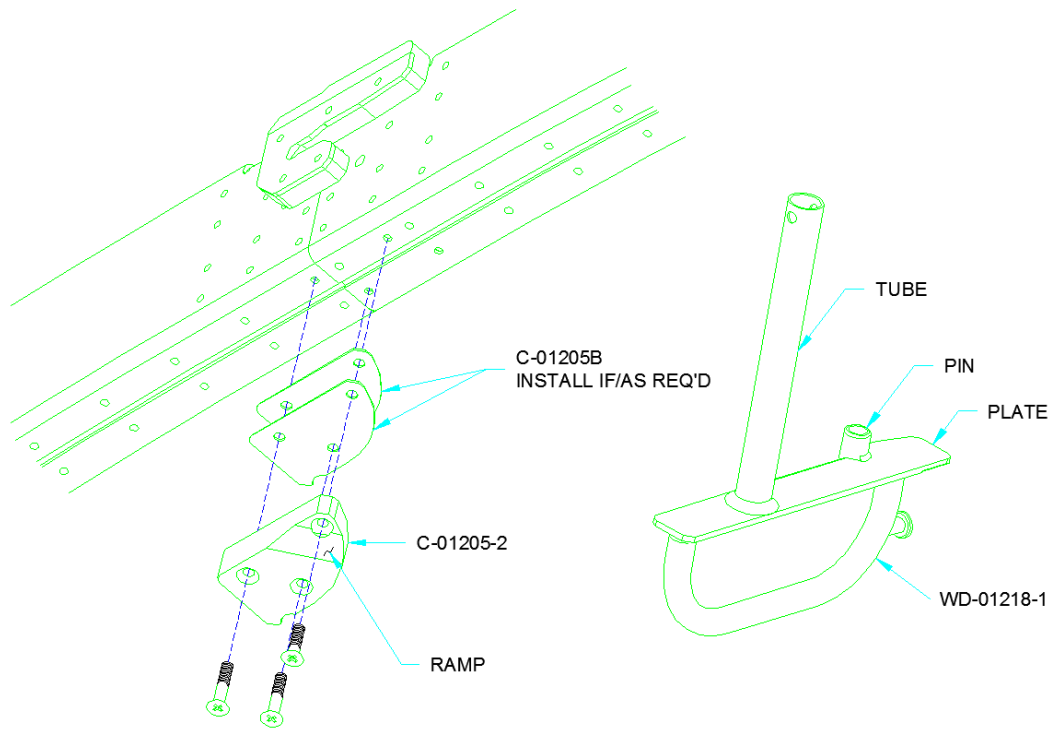

FIGURE 8: SHIM INSTALLATION

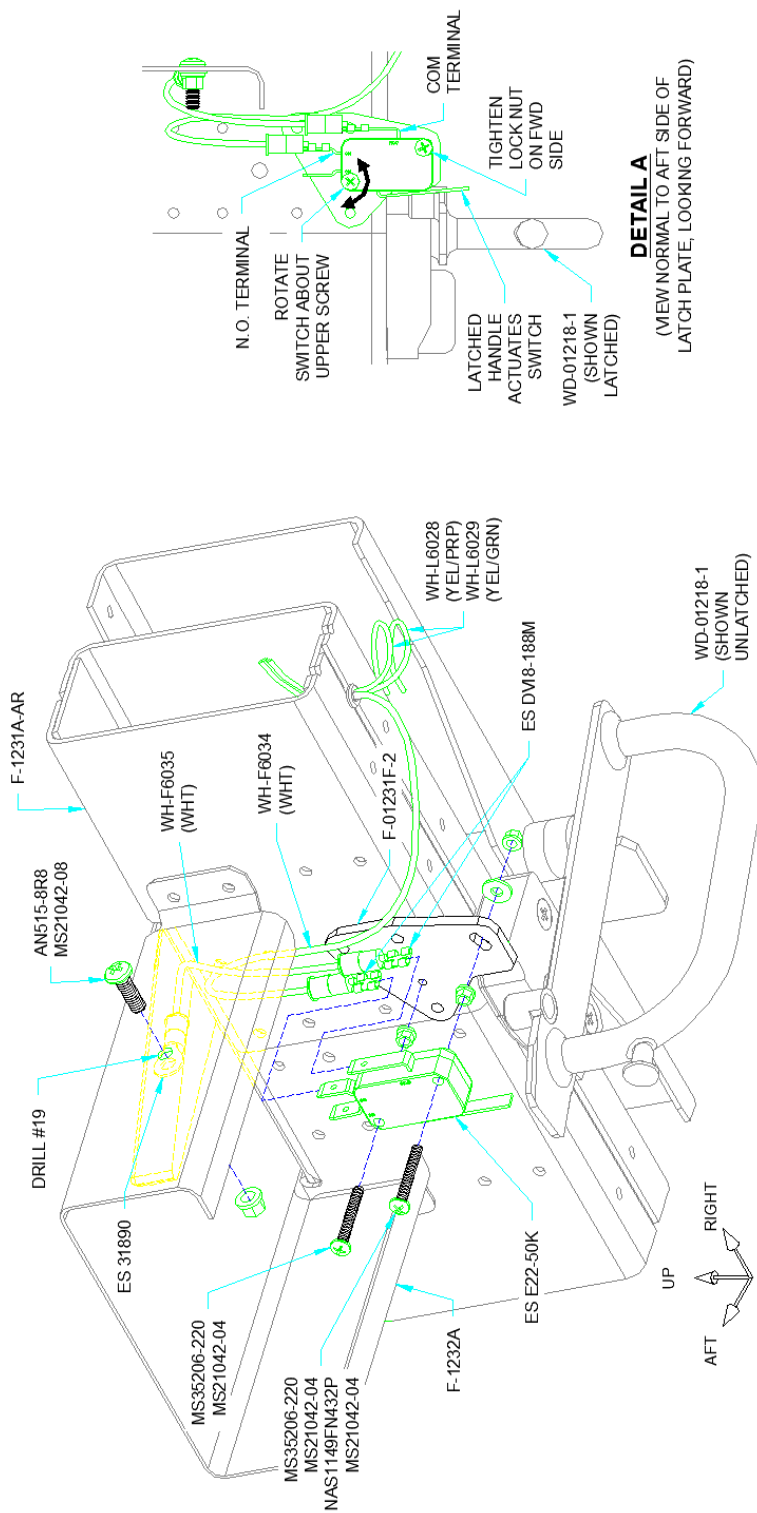

FIGURE 9: CANOPY LATCH SWITCH INSTALLATION

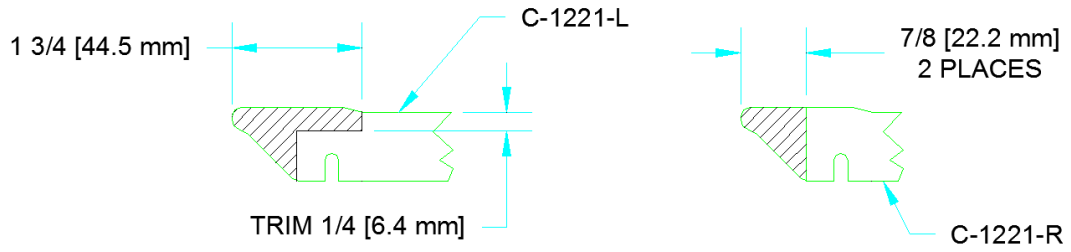

FIGURE 10: MODIFYING THE RETAINERS

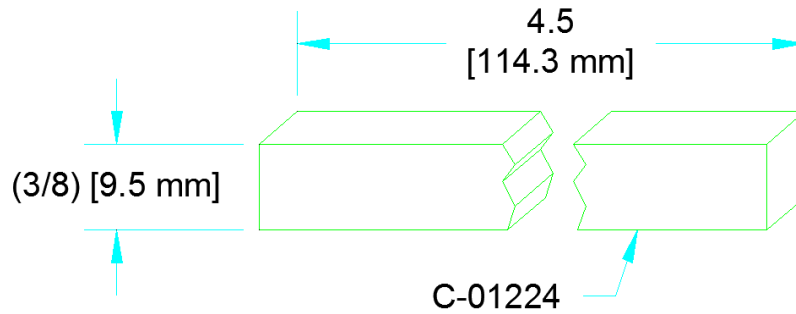
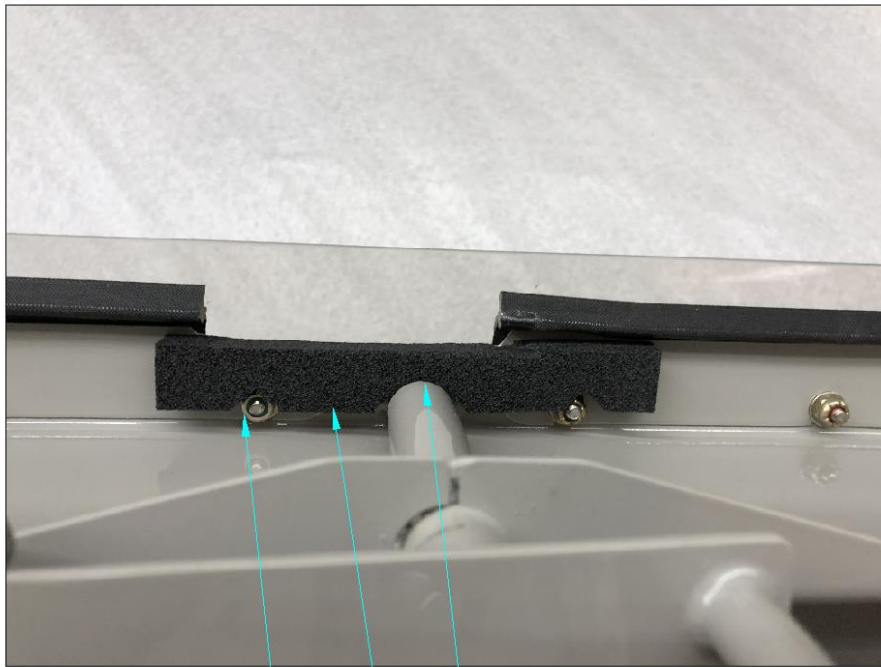

FIGURE 11: FABRICATE THE LATCH SEAL



NOTCH FOR CANOPY
ATTACH FASTENERS,

NOTCH FOR
CANOPY HANDLE

FIGURE 12: CANOPY UPPER CENTER SEAL BOTTOM VIEW

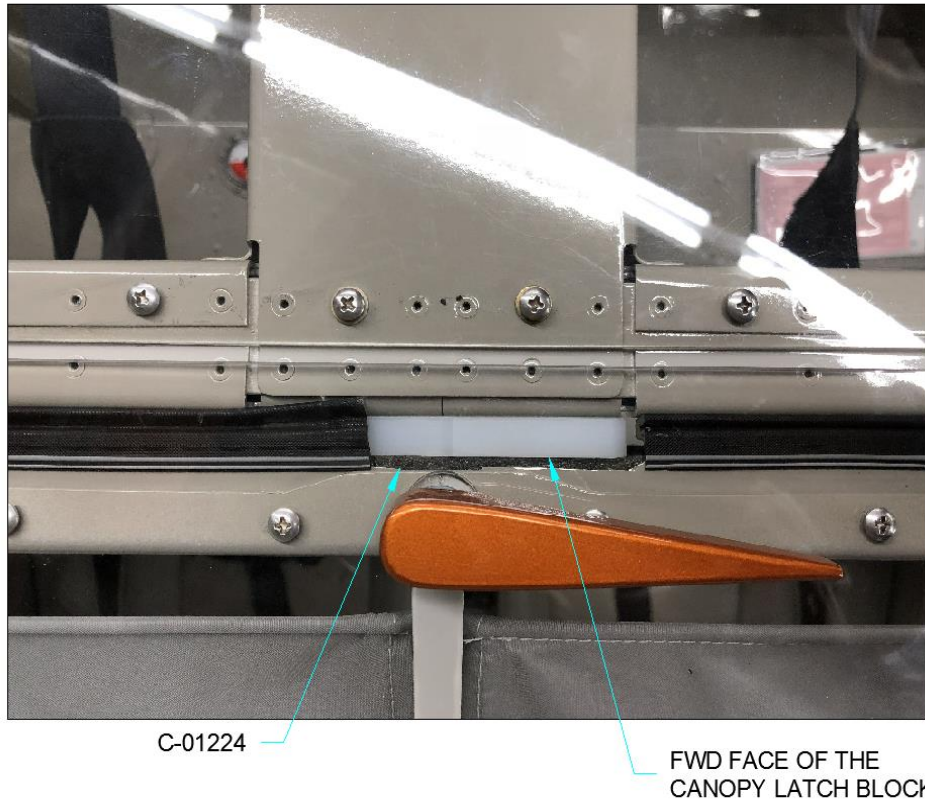

FIGURE 13: CANOPY UPPER CENTER SEAL TOP VIEW

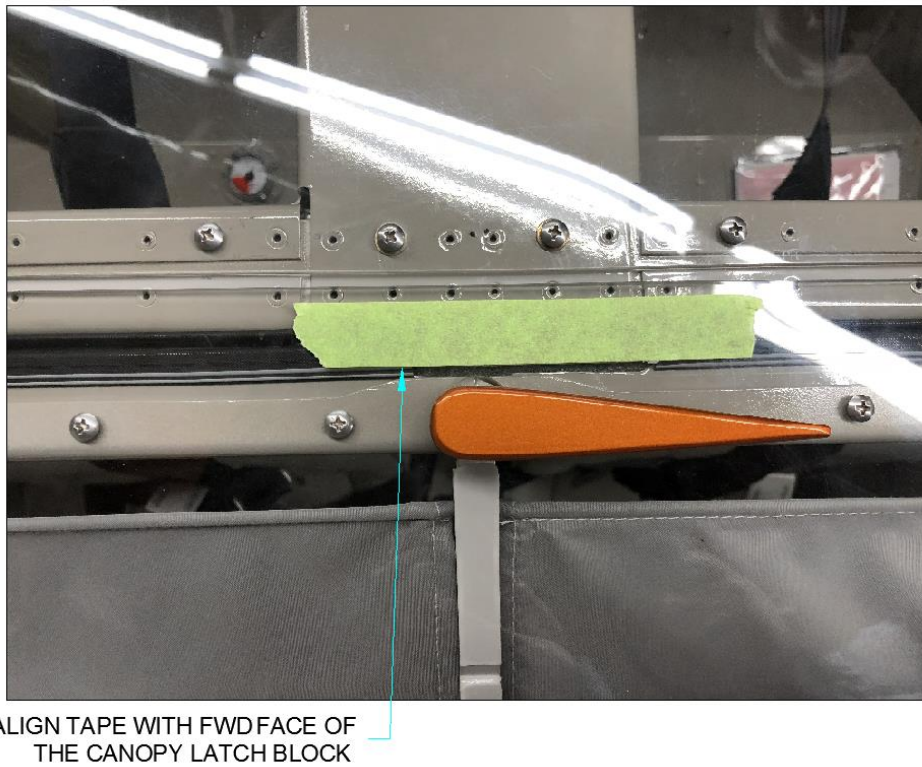

FIGURE 14: CANOPY UPPER CENTER SEAL POSITION

PART NUMBERS

Order: 12 CANOPY LATCH/HANDLE UPGRADE

Note: Other parts may be required, dependent on whether N 16-20-03 and N 14-05-22 have been installed (or the equivalent parts installed during construction)