

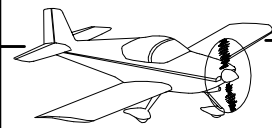
# SECTION 12: EMPENNAGE FAIRINGS

VS-1213  
V-STAB TIP FAIRING

R-1206  
RUDDER TIP FAIRING

F-1294A  
UPPER TAILCONE FAIRING

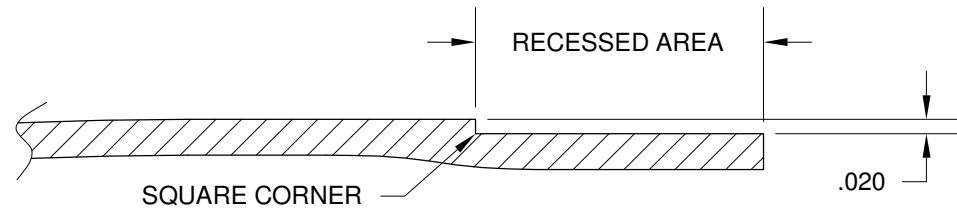
F-1294B  
LOWER TAILCONE FAIRING



**NOTE: Begin this section with the V-Stab, Rudder, Trim/Servo and Stabilator Assemblies removed from the Tailcone Assembly.**

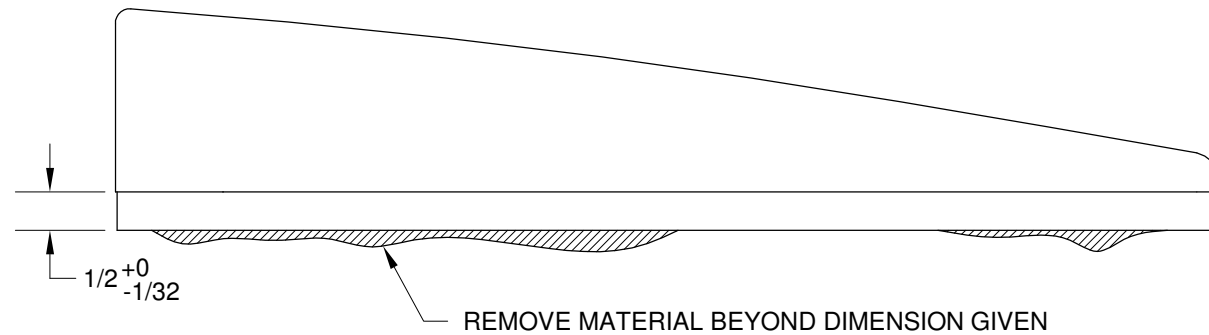
**NOTE: Tools will dull rapidly when used on fiberglass. Set aside a specific set of tools for use on fiberglass only. See Section 5T for more information on working with fiberglass.**

**Step 1:** Ensure that the molded recessed area on both of the tip fairings has a square corner as shown in Figure 1. Use a razor blade or file to remove any material that may have been left from the mold.



**FIGURE 1:**  
VS-1213 AND R-1206 TIP FAIRING MOLDED FLANGE

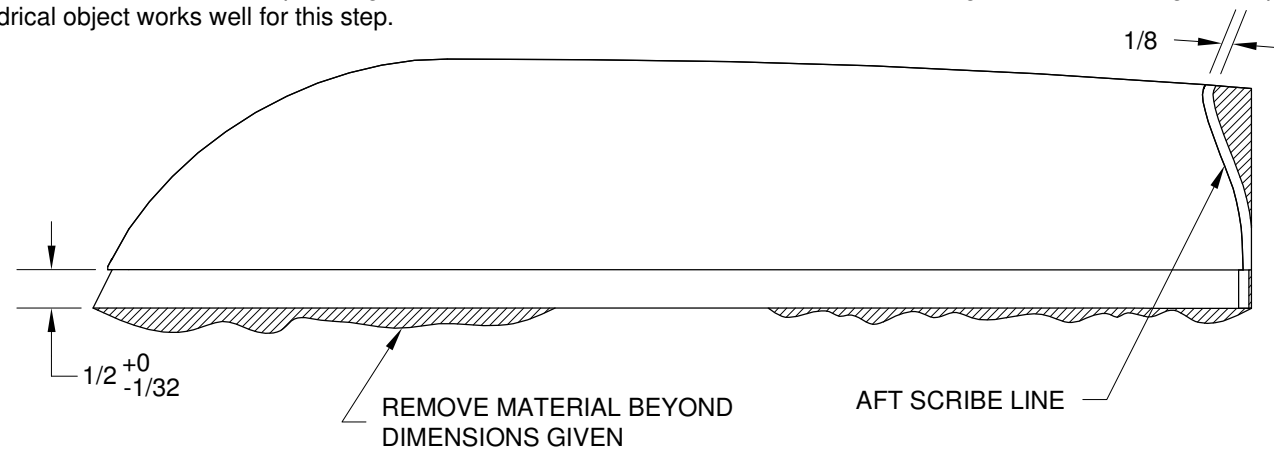
**Step 2:** Trim any extra material from the recessed area of the R-1206 Rudder Tip Fairing per dimension given in Figure 2. Coarse 80 grit sandpaper on a wood block works well for this step.



**FIGURE 2:**  
R-1206 RUDDER TIP FAIRING

**Step 3:** Trim any extra material from the recessed area of the VS-1213 V-Stab Tip Fairing per dimensions given in Figure 3.

**Step 4:** Trim the VS-1213 V-Stab Tip Fairing to within 1/8 inch of the aft scribe line as shown in Figure 3. Coarse 80 grit sandpaper on a cylindrical object works well for this step.



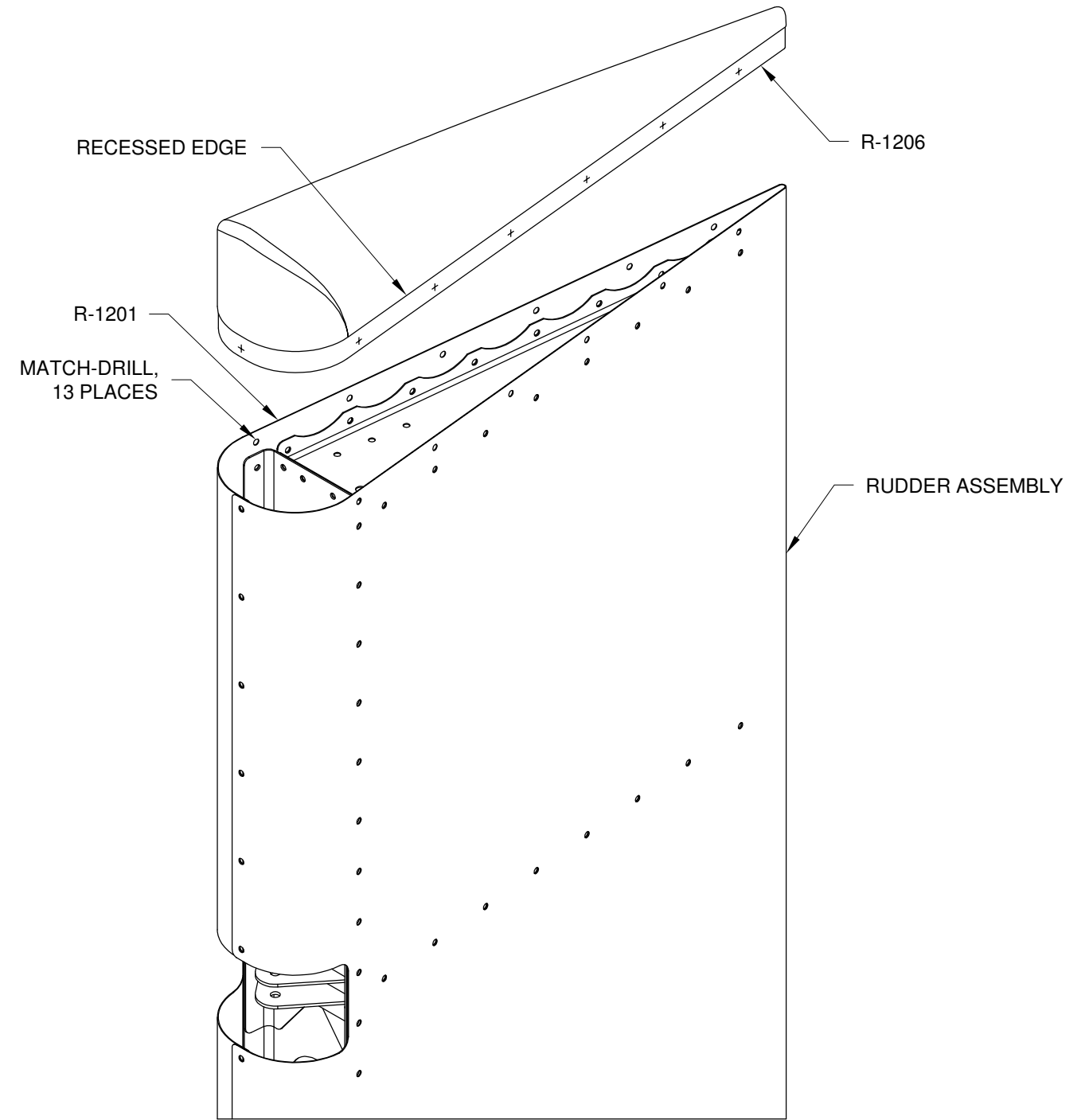
**FIGURE 3:**  
VS-1213 V-STAB TIP FAIRING

**Step 5:** Place the R-1206 Rudder Tip Fairing onto the Rudder Assembly. The edge of the recessed area of the rudder tip fairing must be flush against the entire top edge of the R-1201 Main Skin.

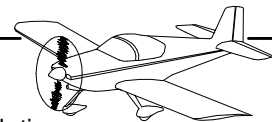
To resolve interference issues, recheck the recessed area measurement with the dimension given in Figure 2. Remove the minimum amount of material necessary, within that dimension, to achieve a flush fit to the top edge of the main skin.

**Step 6:** While holding the R-1206 Rudder Tip Fairing in place Match-Drill #30 the holes from the R-1201 Main Skin into the rudder tip fairing as shown in Figure 4. Cleco each hole before drilling the next.

Remove, clean and deburr, then cleco in place.



**FIGURE 4:**  
RUDDER TIP FAIRING



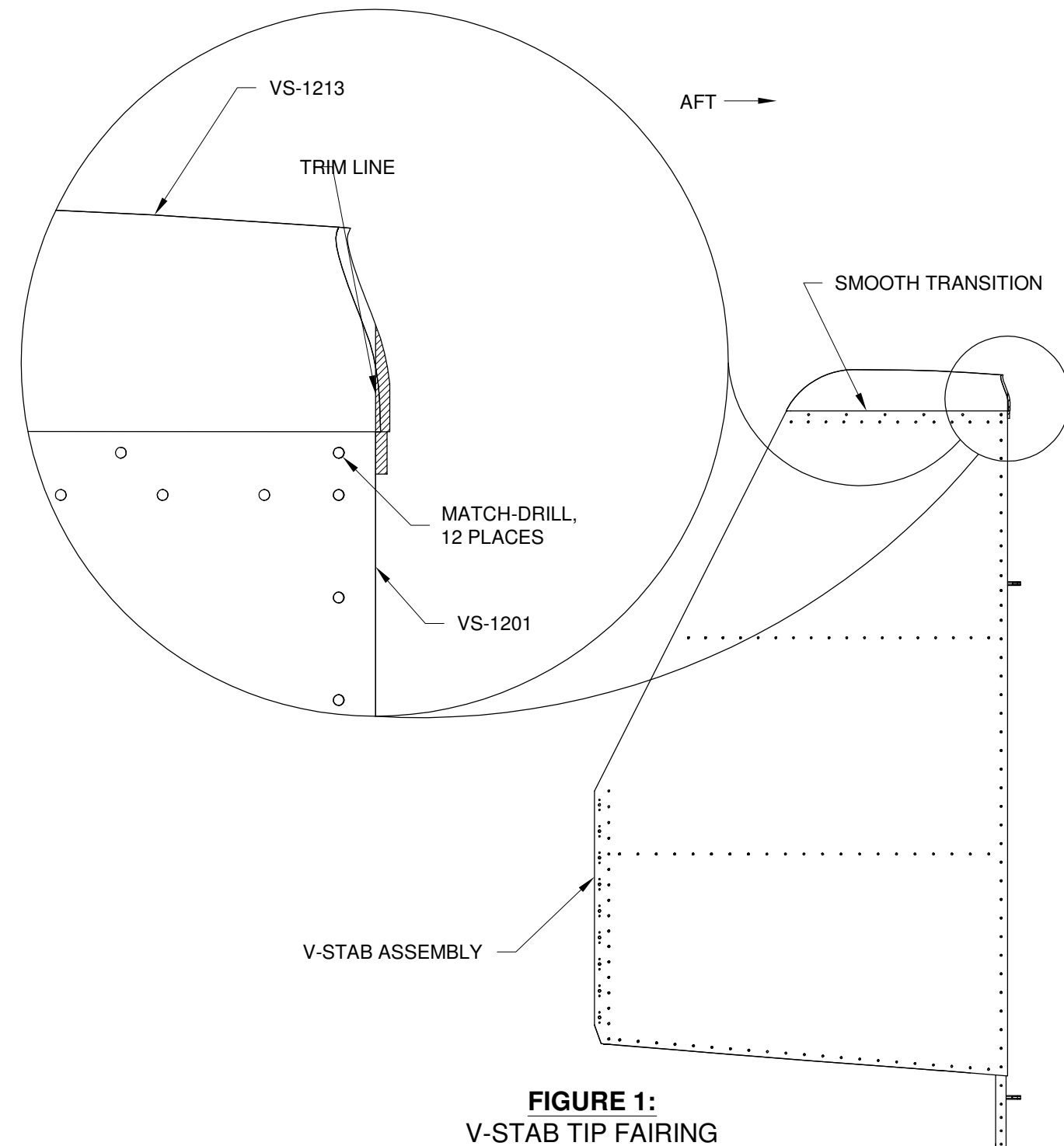
**Step 1:** Place the VS-1213 V-Stab Tip Fairing onto the V-Stab Assembly. The edge of the recessed area of the v-stab tip fairing must be flush against the entire top edge of the VS-1201 Main Skin as shown in Figure 1.

To resolve interference issues, recheck the recessed area measurement with the dimension given on Page 12-02, Figure 3. Remove the minimum amount of material necessary, within that dimension, to achieve a flush fit to the top edge of the main skin.

**Step 2:** With the VS-1213 V-Stab Tip Fairing in place, Match-Drill #30 the holes from the VS-1201 Main Skin into the v-stab tip fairing as shown in Figure 1. Cleco each hole before drilling the next.

**Step 3:** Make a smooth transition from the surface of the v-stab tip fairing to the surface of the VS-1201 Main Skin. Remove the v-stab tip fairing, sand the surface of the fairing where necessary, then check and repeat until the transition is smooth. Mark the fairing with a trim line that follows the aft edge of the VS-1201 Main Skin as shown in Figure 1.

**Step 4:** Trim the VS-1213 V-Stab Tip Fairing at the trim line from Step 3.

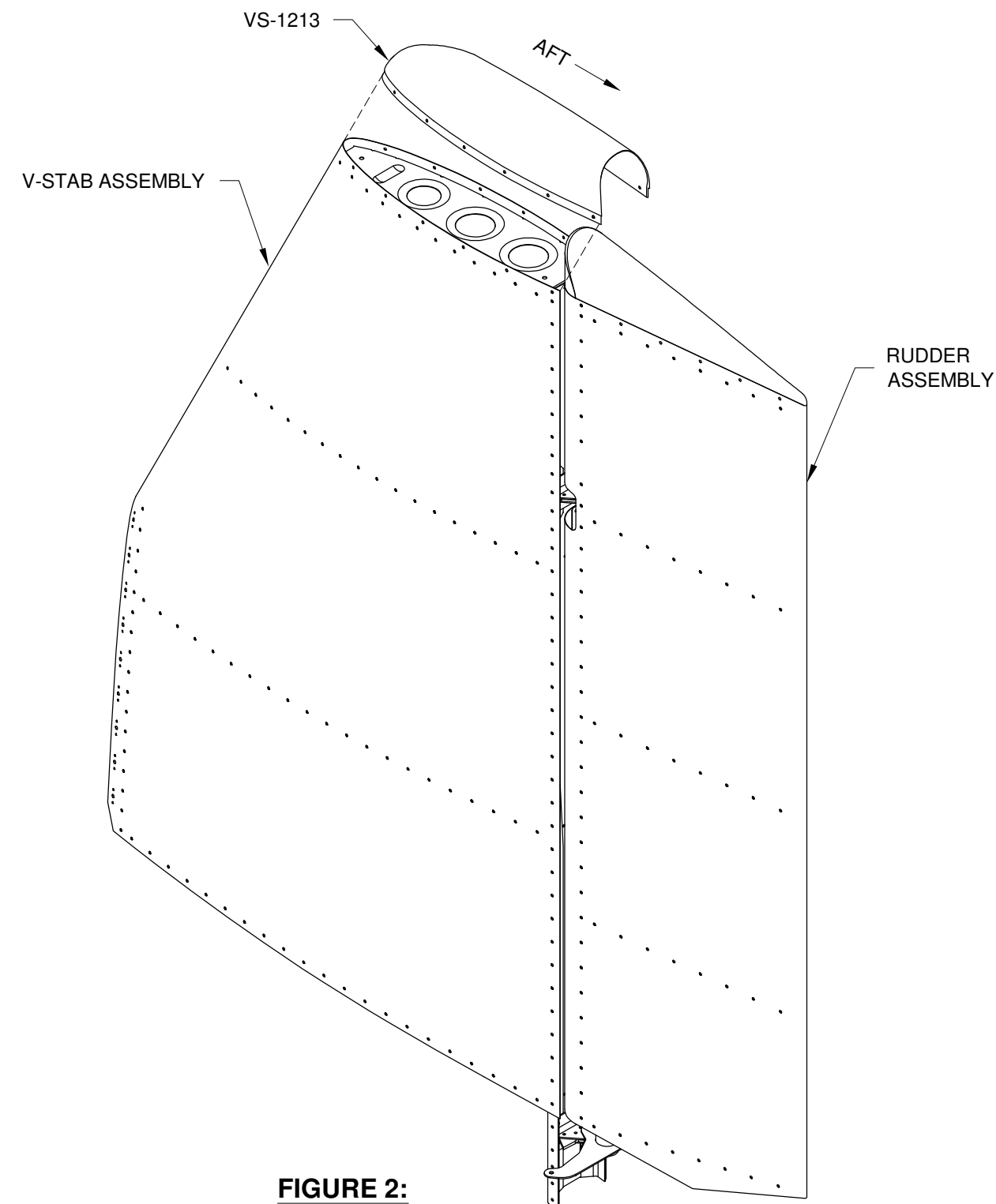


**FIGURE 1:**  
V-STAB TIP FAIRING

**Step 5:** Temporarily attach the Rudder Assembly to the V-Stab Assembly. Refer to Section 11, Page 2 for attachment instructions.

**Step 6:** Place the VS-1213 V-Stab Tip Fairing in position as shown in Figure 2. Mark the aft edge of the v-stab tip fairing to indicate any material that is within 1/8 of the Rudder Assembly. Remove the fairing, then trim to the marked areas to provide clearance for the Rudder Assembly. Repeat, as necessary, to achieve a minimum of 1/8 inch clearance but not more than 1/4 inch of clearance throughout the Rudder Assembly travel.

Smooth the trimmed edge with sandpaper, finish sand the entire v-stab tip fairing and wipe away loose material. Re-cleco in place.



**FIGURE 2:**  
TIP FAIRING CLEARANCE



Step 1: Remove the Rudder Assembly from the V-Stab Assembly.

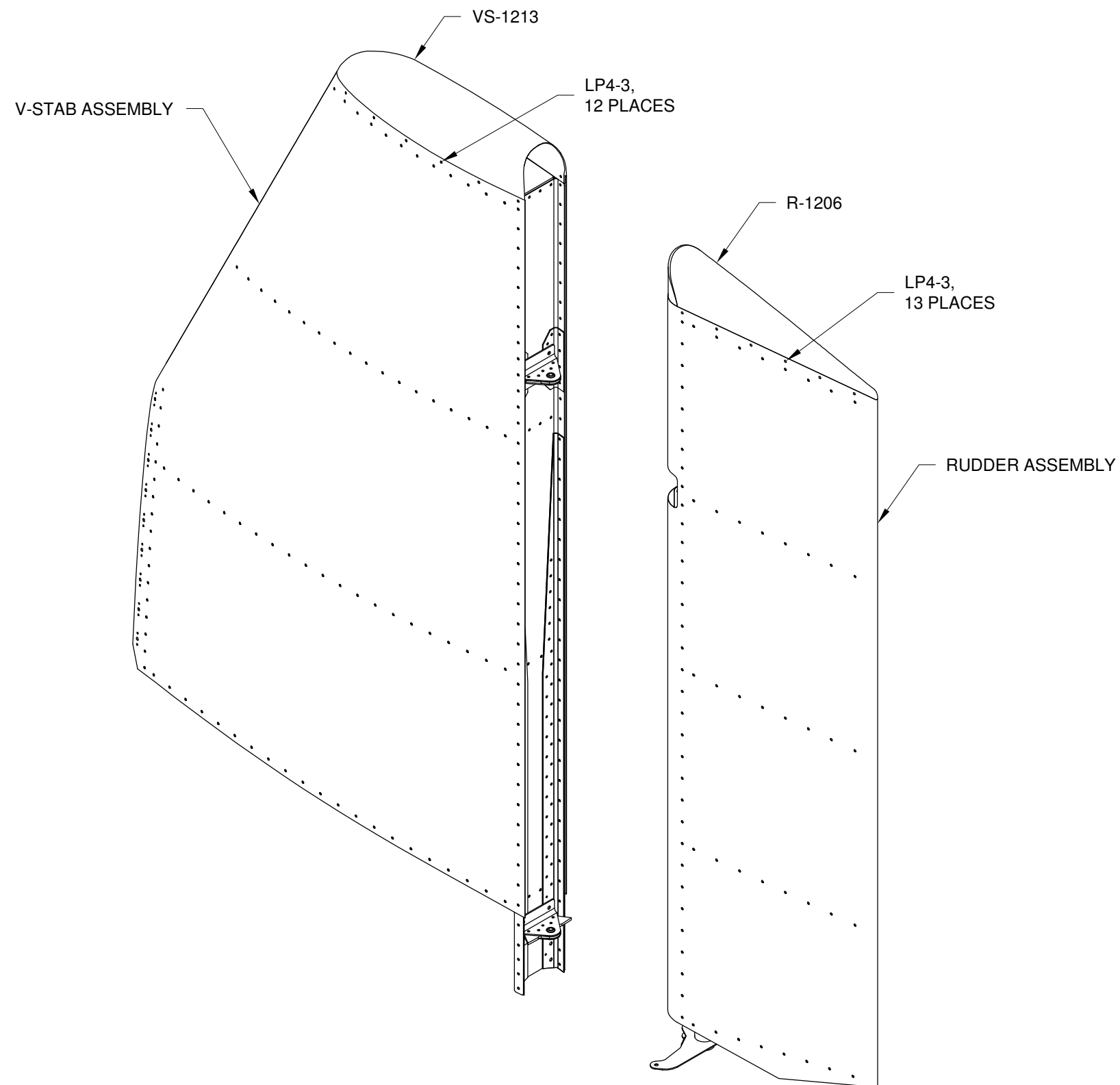
Step 2: Rivet the VS-1213 V-Stab Tip Fairing to the V-Stab Assembly using the rivets called out in Figure 1.

Step 3: Rivet the R-1206 Rudder Tip Fairing to the Rudder Assembly using the rivets called out in Figure 1.

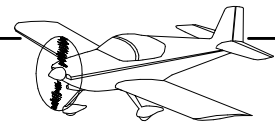
**NOTE: The completion of this section must be postponed until just prior to Section 32 since the F-1294A and F-1294B are shipped in the Finish Kit.**

**NOTE: For Step 4 refer to Page 11-02.**

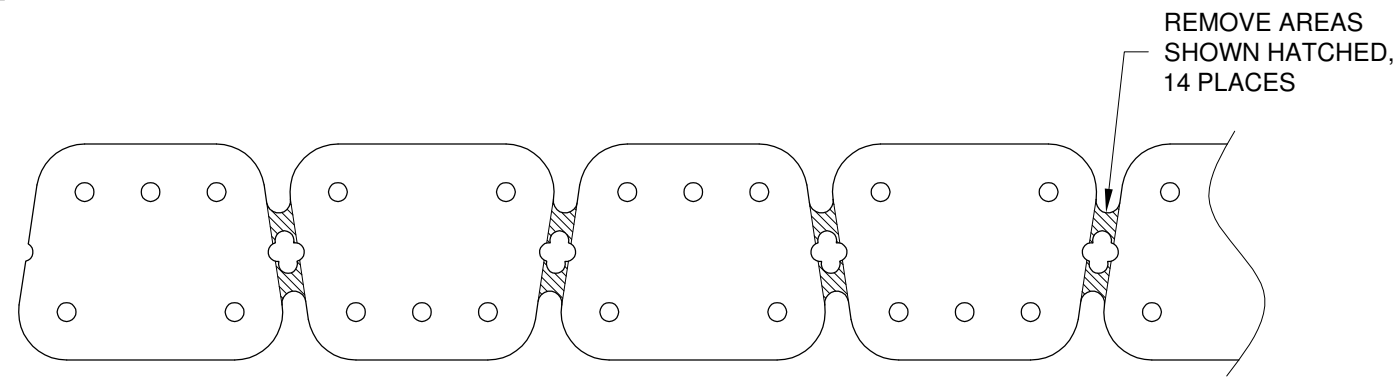
Step 4: Install the V-Stab Assembly to the Tailcone Assembly.



**FIGURE 1:**  
TIP FAIRING INSTALLATION



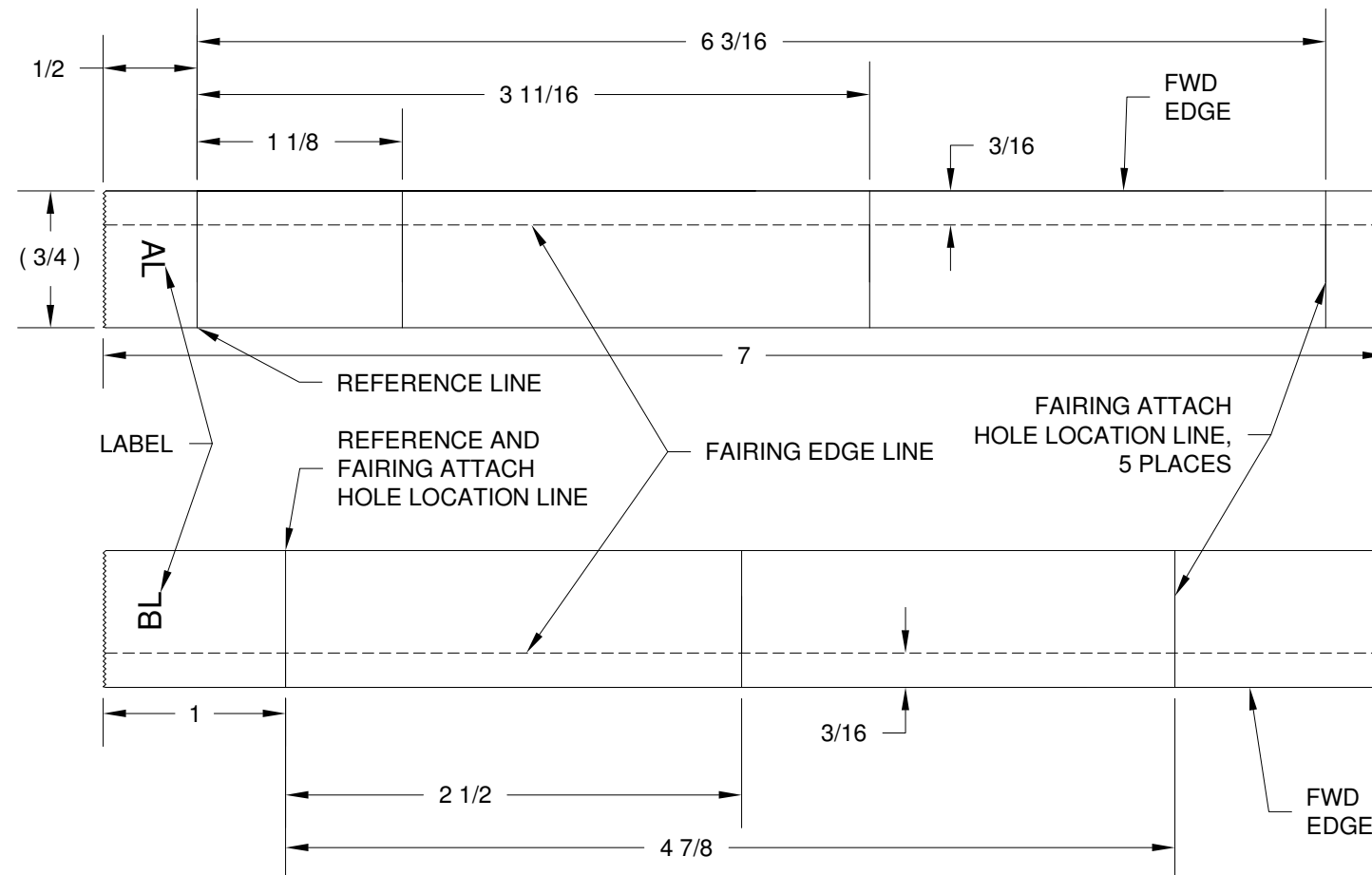
Step 1: Separate the F-1294C Tabs by removing the material called out in Figure 1.



**FIGURE 1:**  
F-1294C TAB SEPARATION

Step 2: Mark two lengths of masking tape per dimensions in Figure 2. One will be the 'AL', which will be for the upper left half of the tailcone. The other will be the 'BL', which will be for the lower left half of the tailcone. Use a pen that makes dark lines.

Mark two more pieces of masking tape as a mirror of the first two, label them 'AR' and 'BR' for the right side of the tailcone.



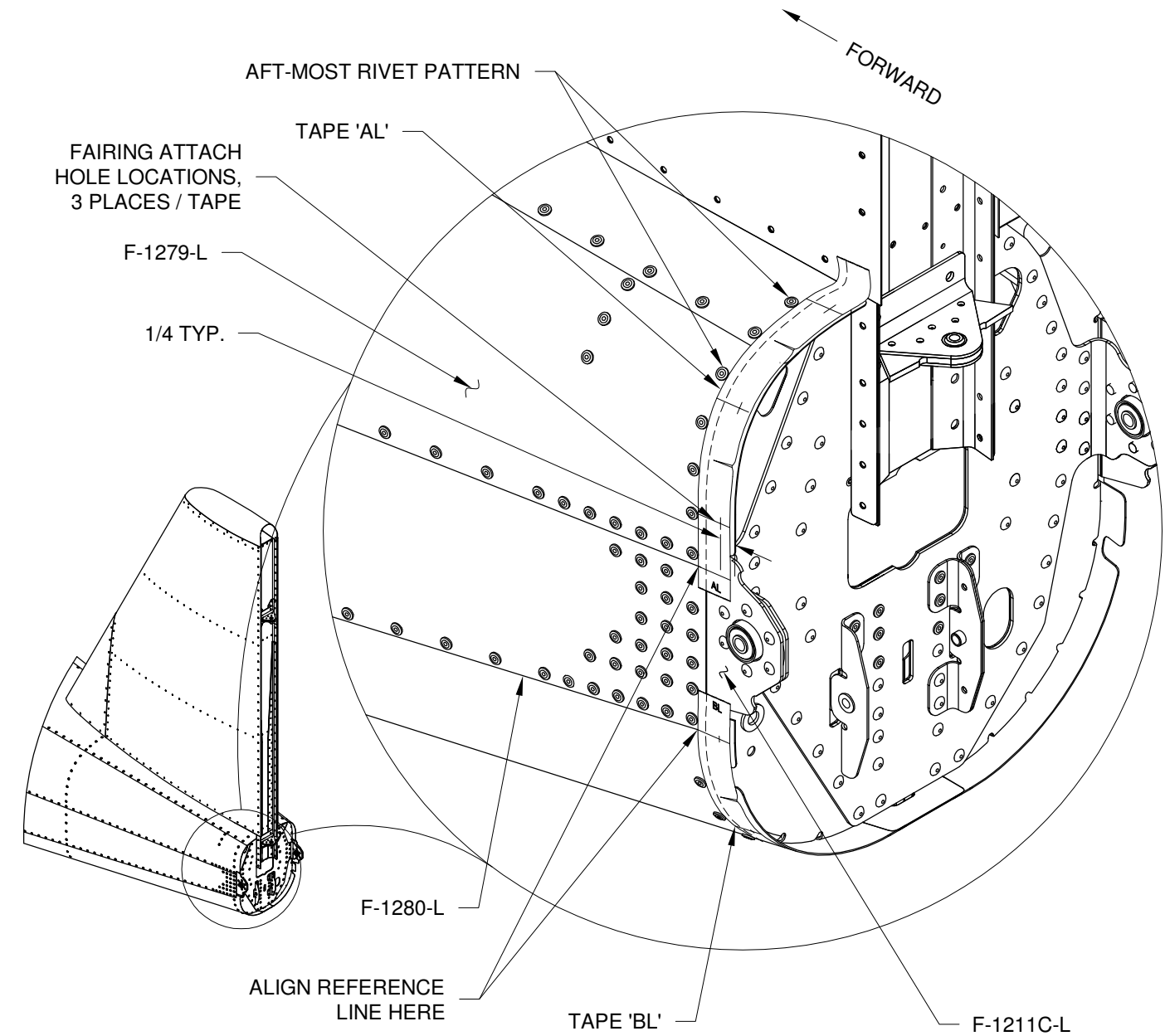
**FIGURE 2:**  
MASKING TAPE MARKING  
(NOT TO SCALE)

Step 3: Place the forward end of the reference line of tape 'AL' on the lower edge of the F-1279-L Upper Corner Skin. Align the forward edge of the masking tape along the manufactured heads of the aft-most rivet pattern on the tailcone as shown in Figure 3. Gather wrinkles in the aft edge of the tape between the fairing attach hole marks.

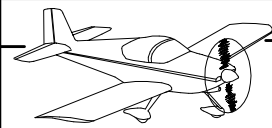
Step 4: Place the forward end of the reference line of tape 'BL' on the lower edge of the F-1280-L Side Skin. Align the forward edge of the masking tape along the aft-most rivet pattern on the tailcone as shown in Figure 3. Gather wrinkles in the aft edge of the tape between the fairing attach hole marks.

Repeat Steps 3 and 4 on the right side of the Tailcone Assembly using tape 'AR' and 'BR'.

Step 5: Measure and mark the dimension given from the aft edge of the tailcone skins, at each fairing attach hole location as shown in Figure 3.



**FIGURE 3:**  
MASKING TAPE POSITIONS



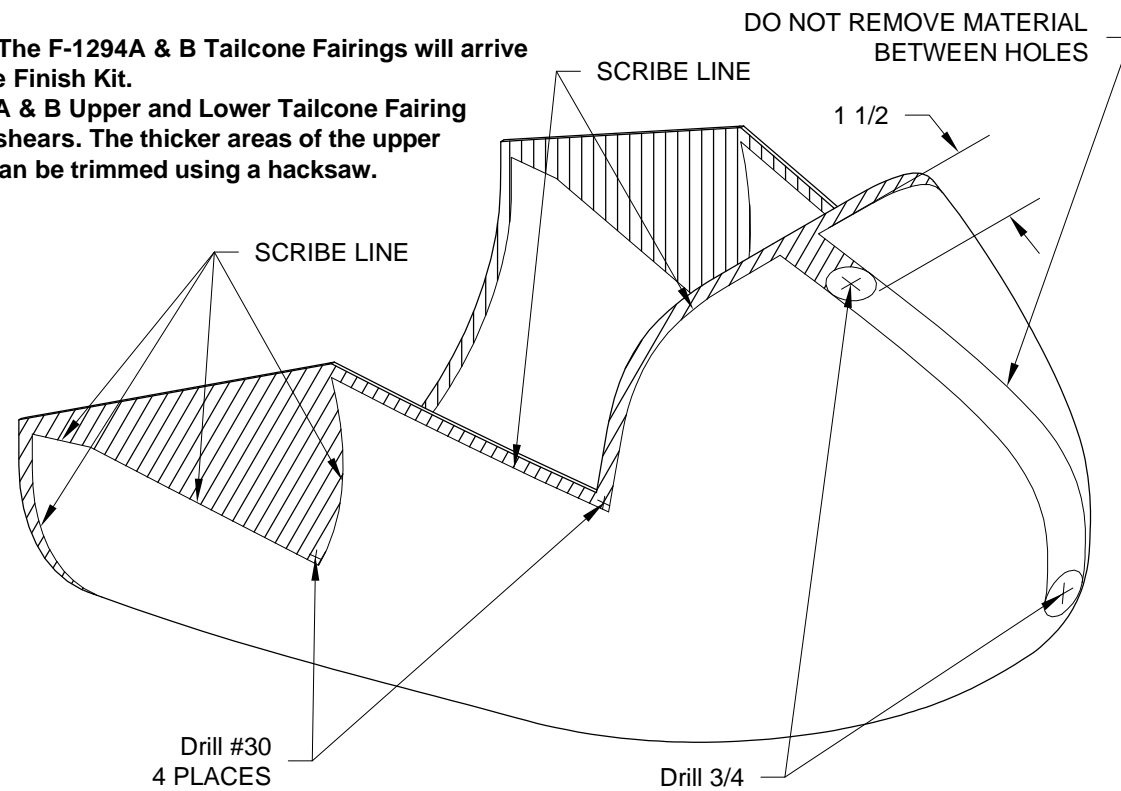
**NOTE: The F-1294A & B Tailcone Fairings will arrive with the Finish Kit.**

**The thin areas of the F-1294A & B Upper and Lower Tailcone Fairing can be trimmed using hand shears. The thicker areas of the upper and lower tailcone fairings can be trimmed using a hacksaw.**

**Step 1:** Drill two holes with a step drill bit in the F-1294B Lower Tailcone Fairing as shown in Figure 1. Drill two holes in each side of the lower tailcone fairing at the locations shown in Figure 1. Place the perimeter of all of the holes within the scribe line.

**Step 2:** Trim the excess material from the F-1294B Lower Tailcone Fairing as shown in Figure 1. Cut close to the scribe line, then use a sanding block to finish the edge to the scribe line.

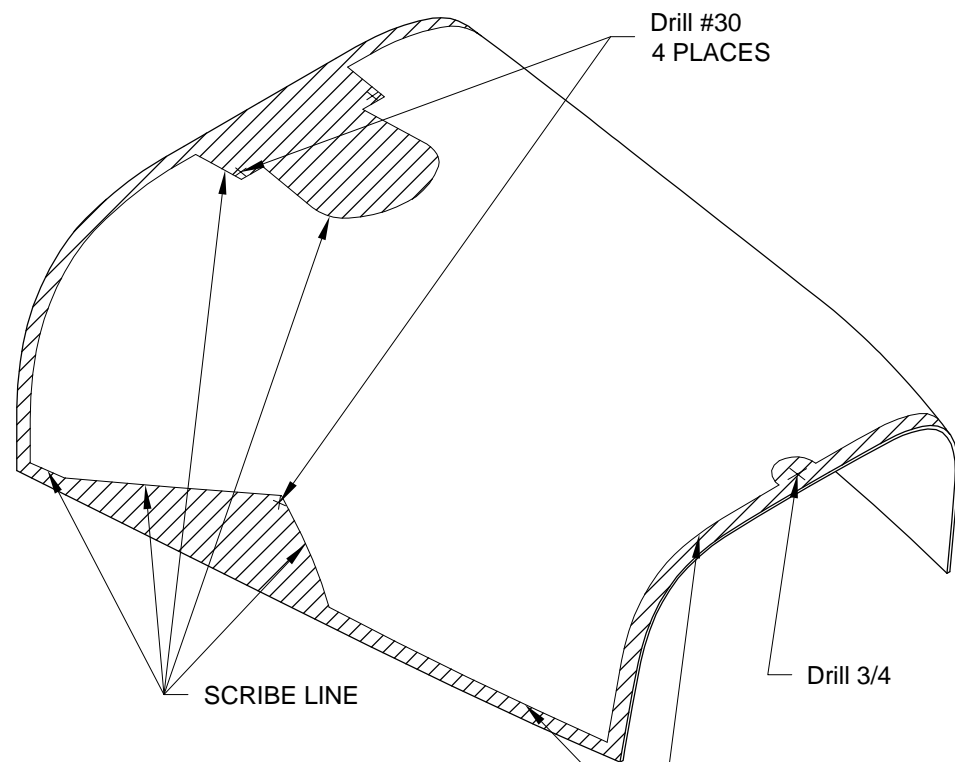
Do not cut away the material between the two 3/4 inch holes drilled in Step 1.



**FIGURE 1:  
TRIMMING THE F-1294B**

**Step 3:** Drill a hole using a step drill bit in the F-1294A Upper Tailcone Fairing as shown in Figure 2. Drill two holes in each side of the upper tailcone fairing at the locations shown in Figure 2. Place the perimeter of the hole as close to the scribe line as possible.

**Step 4:** Trim excess material from the F-1294A Upper Tailcone Fairing as shown in Figure 2. Cut close to the scribe line, then use a sanding block to finish the edge to the scribe line.

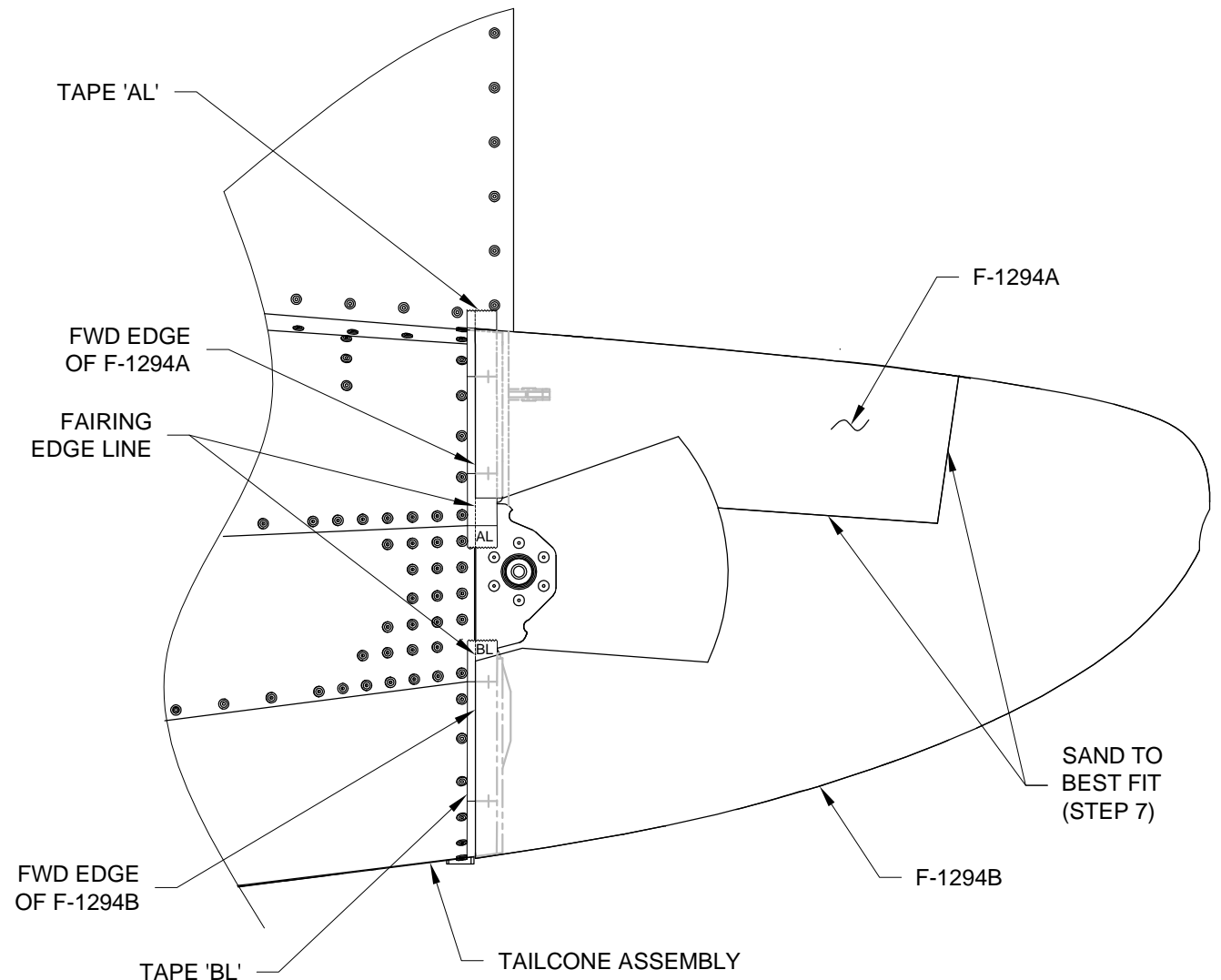


**FIGURE 2:  
TRIMMING THE F-1294A**

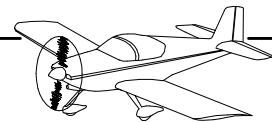
**Step 5:** Align the forward edge of the F-1294B Lower Tailcone Fairing to the fairing edge line (Ref Page 12-05, Figure 2) on tape 'BL' and 'BR' as shown in Figure 3. Temporarily tape or clamp the lower tailcone fairing to the tailcone.

**Step 6:** Align the forward edge of the F-1294A Upper Tailcone Fairing to the fairing edge line on tape 'AL' and 'AR'. Align the notch from the 3/4 inch hole in the upper tailcone fairing with the 3/4 inch slot in the F-1294B Lower Tailcone Fairing.

**Step 7:** Sand the called out edges of the F-1294A & B Upper and Lower Tailcone Fairings for best fit, with minimal gap, see Figure 3. The best fit edges will be finished in a following step.



**FIGURE 3:  
FAIRING FIT**

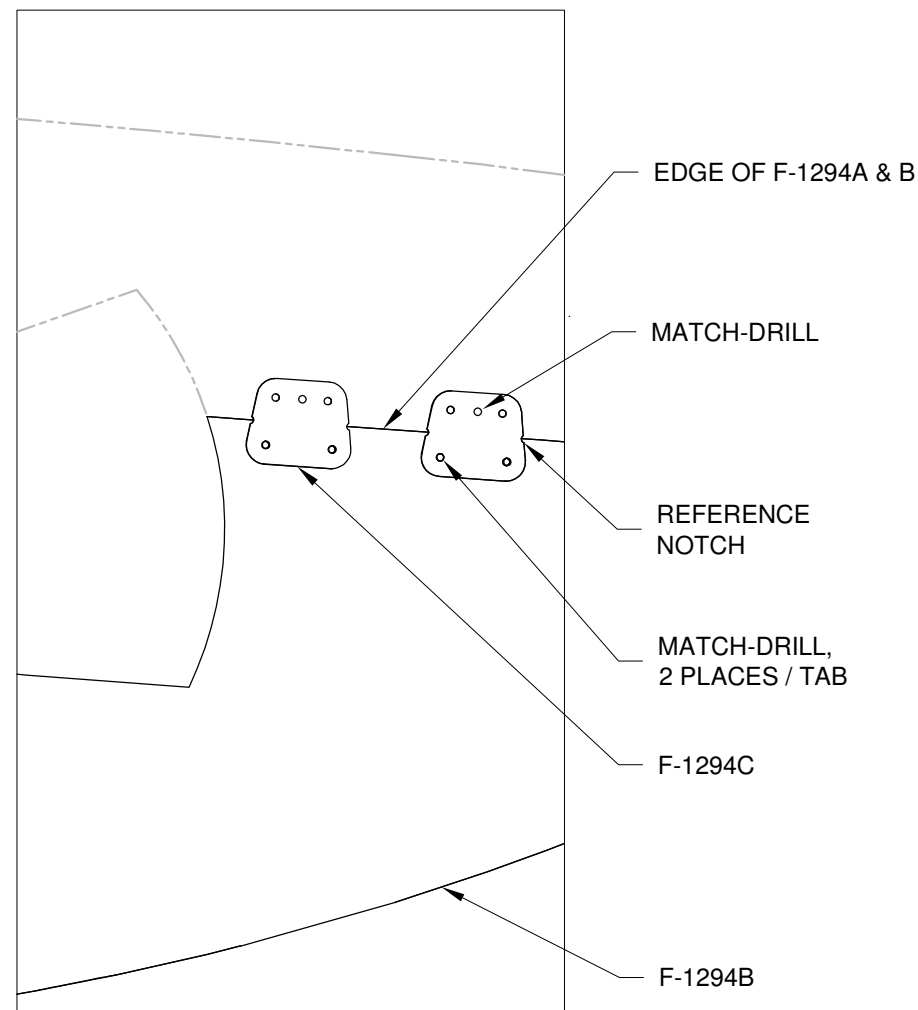


**Step 1:** With the F-1294A Upper Tailcone Fairing set aside, position the F-1294C Tabs on the exterior surface of the F-1294B Lower Tailcone Fairing at the locations shown in Figure 1 (exact location not critical). Align the edge of the lower tailcone fairing to the reference notches on each edge of the tabs as shown in Figure 1, Detail A-A. If/as necessary slightly bend any tab to fit the curve of the lower tailcone fairing. Mark the locations and outer surface of each tab and clamp in place.

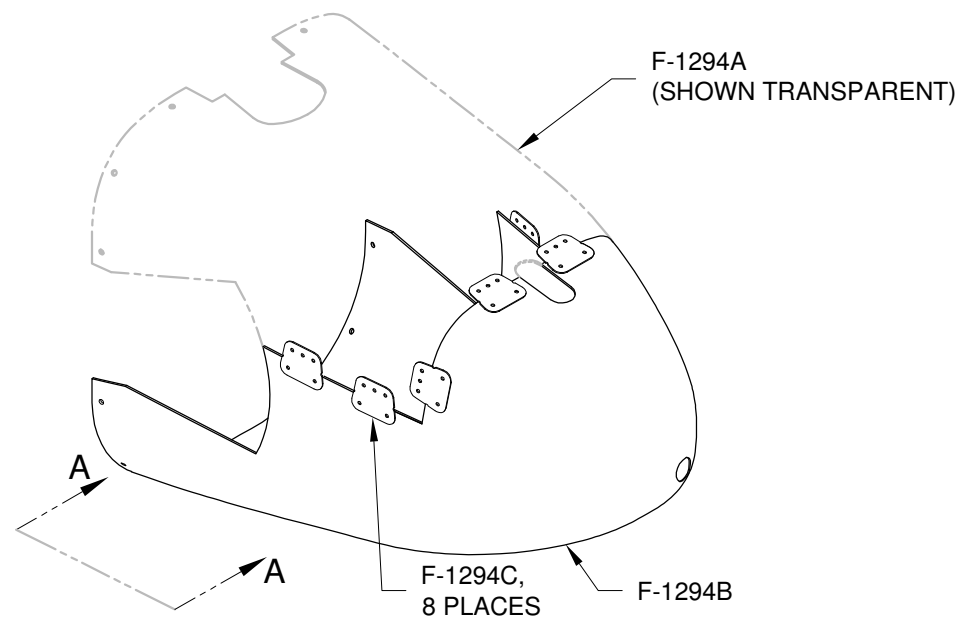
**Step 2:** Match-Drill #40 one of the holes from a F-1294C Tab into the F-1294B Lower Tailcone Fairing. Cleco the hole, then check the alignment of the opposite reference notch to the edge of the lower tailcone fairing. Match-Drill #40 the second hole from the tab into the lower tailcone fairing. Remove, clear away chips and re-cleco.

Repeat Step 2 with the remaining tabs.

**Step 3:** With the F-1294A & B Upper and Lower Tailcone Fairings attached to the tailcone as instructed on Page 12-06, Step 5 and 6, clamp the F-1294A Upper Tailcone Fairing to the F-1294C Tabs that are clecoed to the F-1294B Lower Tailcone Fairing.



**DETAIL A-A**



**FIGURE 1:  
FAIRING TAB POSITIONS**

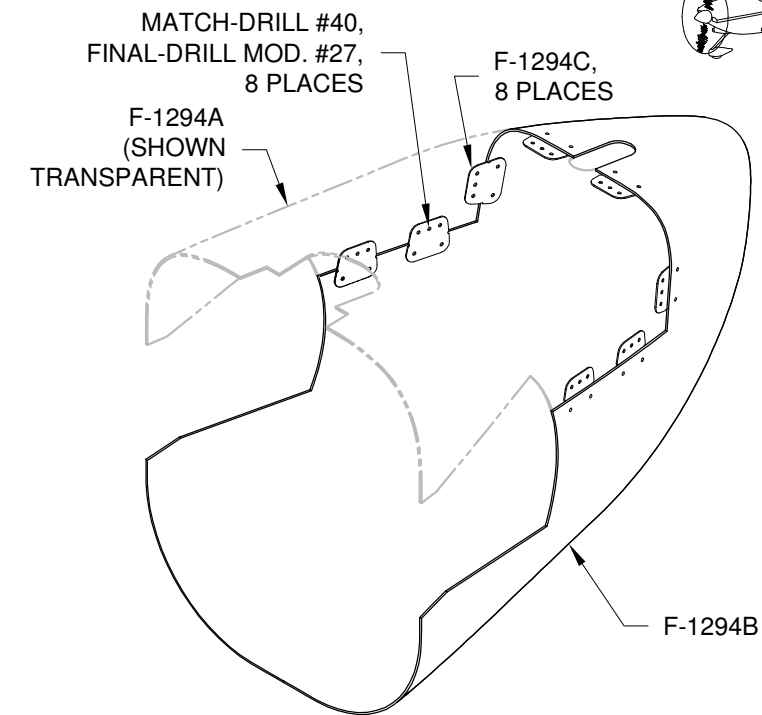
**Step 4:** Match-Drill #40 **only the middle hole** from each F-1294C Tab into the F-1294A Upper Tailcone Fairing.

Separate the upper and lower tailcone fairings, remove the tabs, clean up the holes and clear away any loose material.

**Step 5:** Cleco the F-1294C Tabs to the inside surface of the F-1294B Lower Tailcone Fairing. Cleco the F-1294A Upper Tailcone Fairing to the tabs as shown in Figure 2.

**NOTE:** To make a modified #27 drill bit, drill a 1/8 inch deep hole into concrete using a #27 drill bit. A modified #27 bit will be used occasionally throughout the remainder of the assembly instructions.

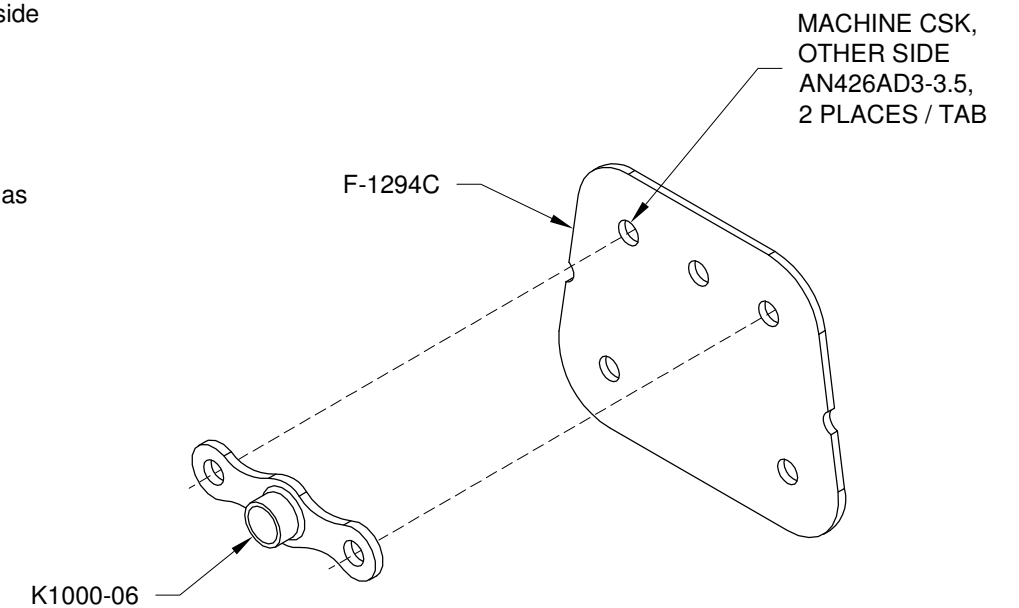
**Step 6:** Final-Drill using a modified #27 bit, then cleco each of the F-1294C Tab center holes common to the F-1294A Upper Tailcone Fairing as shown in Figure 2. Remove the upper tailcone fairing and tabs, clear away loose material.



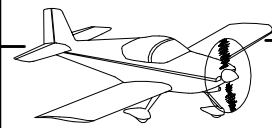
**FIGURE 2:  
TAB FINAL-DRILL**

**Step 7:** Machine countersink the outside surface of the F-1294C Tab at each nutplate attach rivet hole as shown in Figure 3.

**Step 8:** Rivet a nutplate to the inside surface of each of the F-1294C Tabs as shown in Figure 3.

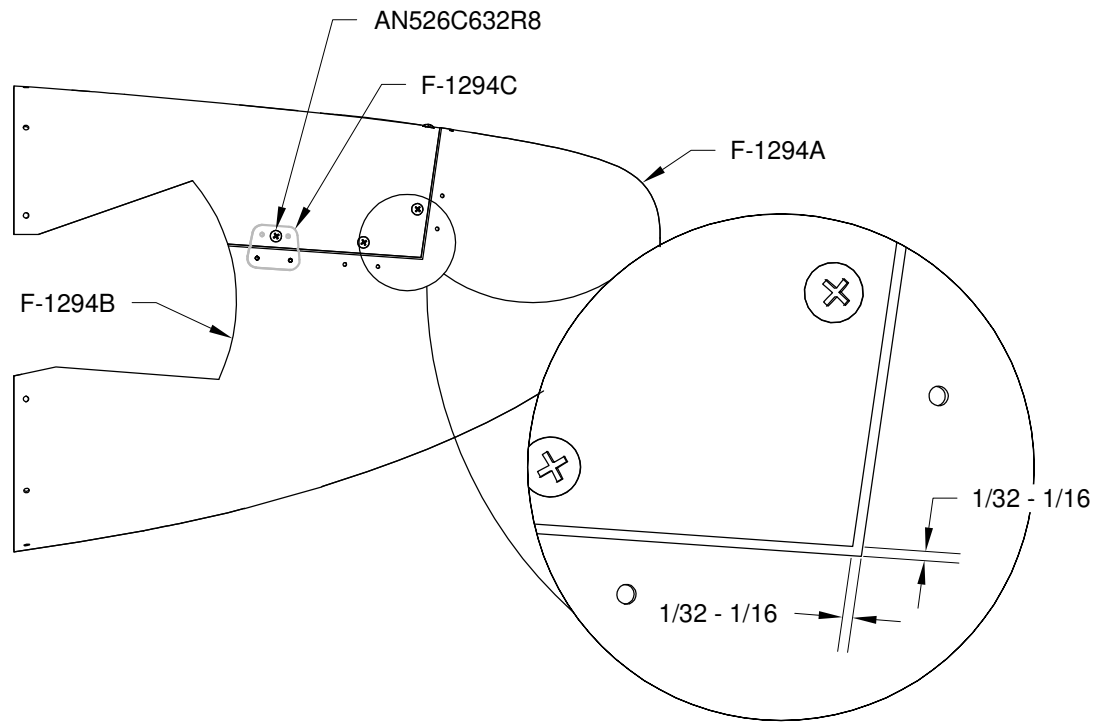


**FIGURE 3:  
F-1294C NUTPLATES**



Step 1: Cleco the F-1294C Tabs to the F-1294B Lower Tailcone Fairing. Temporarily screw the F-1294A Upper Tailcone Fairing to the tabs as shown in Figure 1.

Step 2: Mark, separate, then sand an even gap between the mating edges of the F-1294A & B Upper and Lower Tailcone Fairings per the dimensions given in Figure 1.

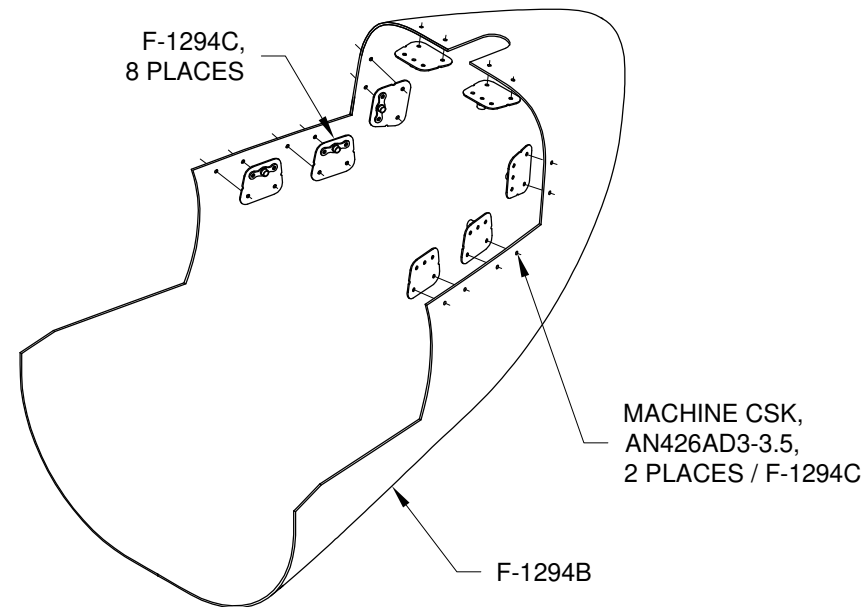


**FIGURE 1:**  
F-1294 ASSEMBLY GAP

Step 3: Countersink the #40 holes in the F-1294B Lower Tailcone Fairing per call-out in Figure 2.

**CAUTION:** When setting solid rivets in fiberglass it is permitted to only partially set the rivets to avoid crushing the fiberglass.

Step 4: Rivet the F-1294C Tabs to the F-1294B Lower Tailcone Fairing using the rivets called out in Figure 2.



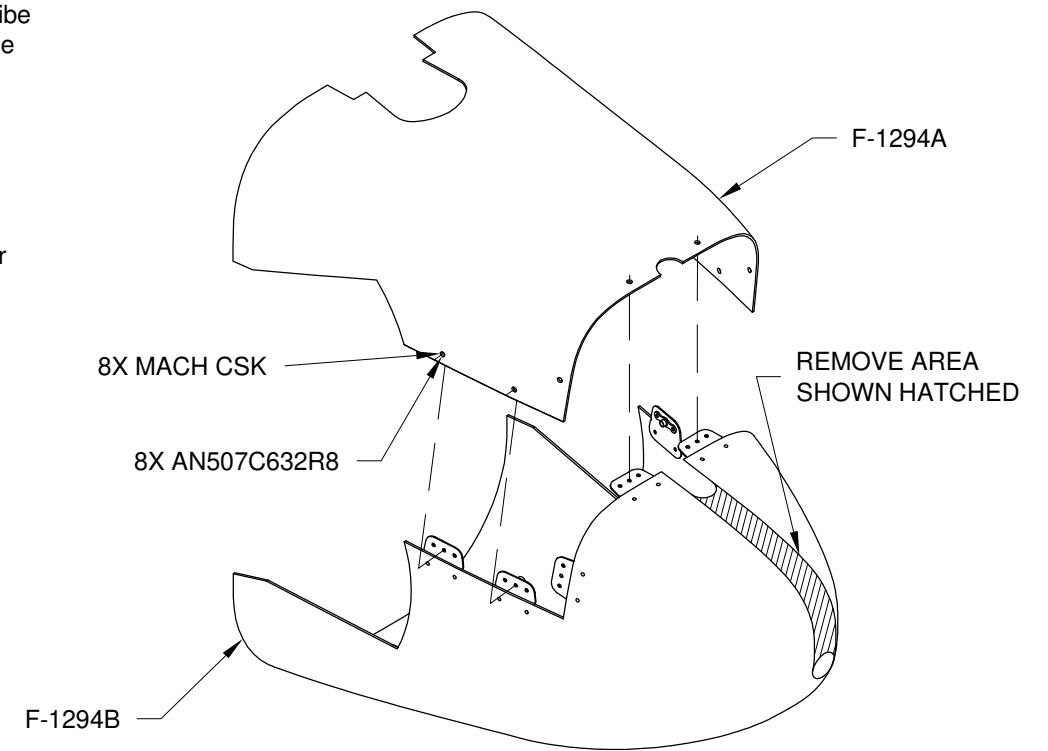
**FIGURE 2:**  
TAB INSTALLATION

Step 5: Trim the aft slot to the scribe line in the F-1294B Lower Tailcone Fairing by removing the material shown hatched in Figure 3.

Step 6: Machine countersink the F-1294A as shown in Figure 3.

Step 7: Attach the F-1294A Upper Tailcone Fairing to the F-1294B Lower Tailcone Fairing using the hardware called out in Figure 3.

Refer to the joined fairings as the F-1294 Assembly.

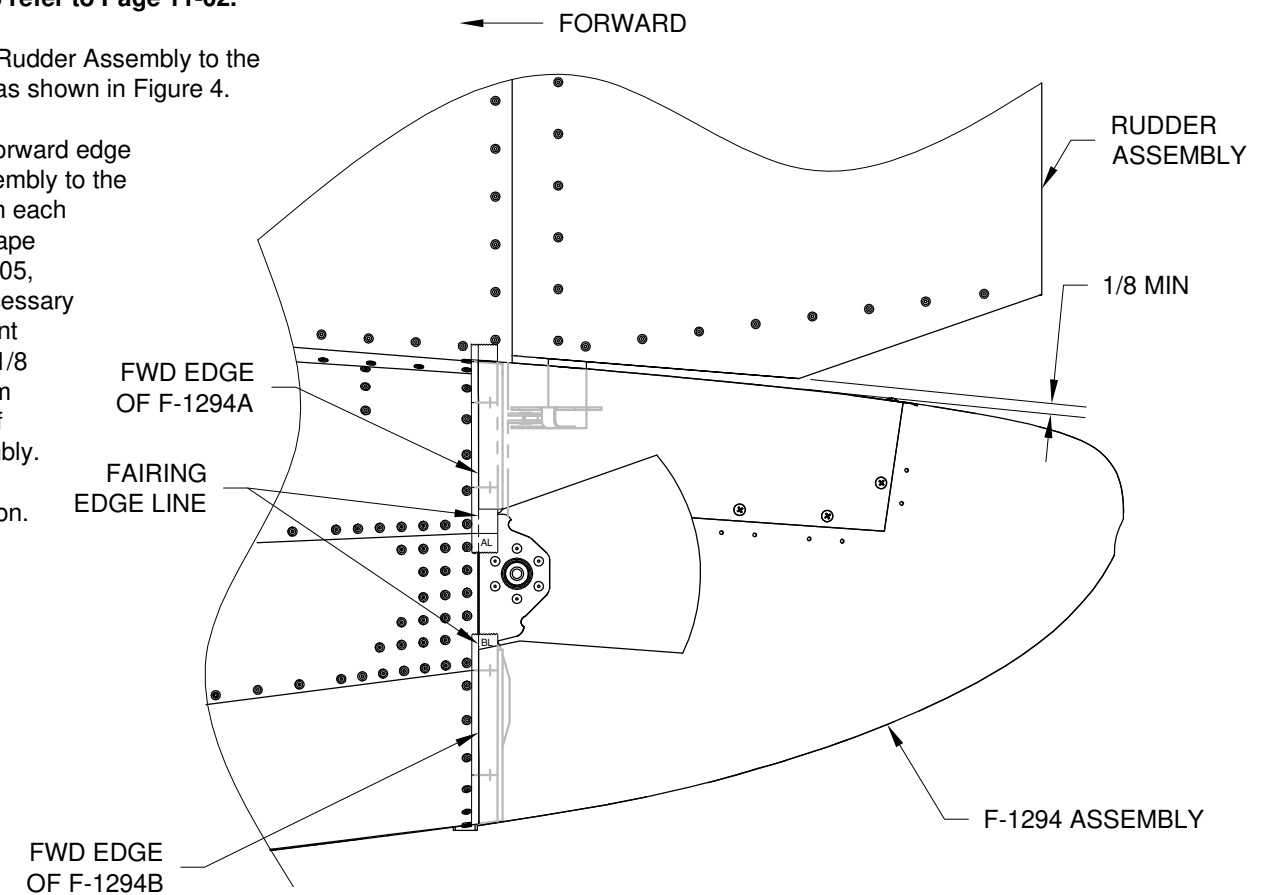


**FIGURE 3:**  
F-1294 ASSEMBLY

**NOTE:** For Step 8 refer to Page 11-02.

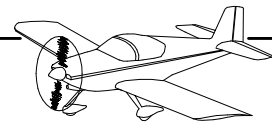
Step 8: Install the Rudder Assembly to the V-Stab Assembly as shown in Figure 4.

Step 9: Align the forward edge of the F-1294 Assembly to the fairing edge line on each piece of masking tape (Refer to Page 12-05, Figure 2). If/as necessary adjust the alignment to ensure at least 1/8 inch clearance from the bottom edge of the Rudder Assembly. Clamp the Fairing Assembly in position.



**FIGURE 4:**  
FAIRING FIT





**NOTE: If required, refer to Section 5.18 MATCH-DRILLING OPAQUE FIBERGLASS PARTS.**

**Step 1:** Drill #40 the F-1294A Upper Tailcone Fairing at the inboard fairing attach hole location marked on masking tape 'AL' as shown in Figure 1, Detail A. Sight through the F-1294A Upper Tailcone Fairing material to locate the fairing attach hole mark, then drill through the upper tailcone fairing into the Tailcone Assembly. Cleco the hole.

**Step 2:** Drill #40 at the inboard fairing attach hole location marked on masking tape 'BL'. Sight through the F-1294B Lower Tailcone Fairing material to locate the fairing attach hole mark then drill through the lower tailcone fairing into the Tailcone Assembly.

**Step 3:** Remove the F-1294 Assembly. Install the Stabilator Assembly. Refer to Section 11, Page 3. Cleco the F-1294 Assembly back in place.

**Step 4:** Adjust the alignment of the F-1294 Assembly to provide at least 1/8 inch of clearance between the F-1294 Assembly and the Stabilator Assembly main skins at any given point throughout the stabilator travel as shown in Figure 1.

**Step 5:** Repeat Steps 1 and 2 to the right side using the 'AR' and 'BR' masking tape.

Re-check clearances between the F-1294 Assembly and the Rudder and Stabilator Assembly main skins.

**Step 6:** With the four existing holes clecoed, drill #40 the remaining fairing attach hole locations marked on masking tapes 'AL', 'BL', 'AR' and 'BR'. Sight through the F-1294A & B Upper and Lower Tailcone Fairing material to locate the marks then drill through the fairing into the Tailcone Assembly. Cleco as you go.

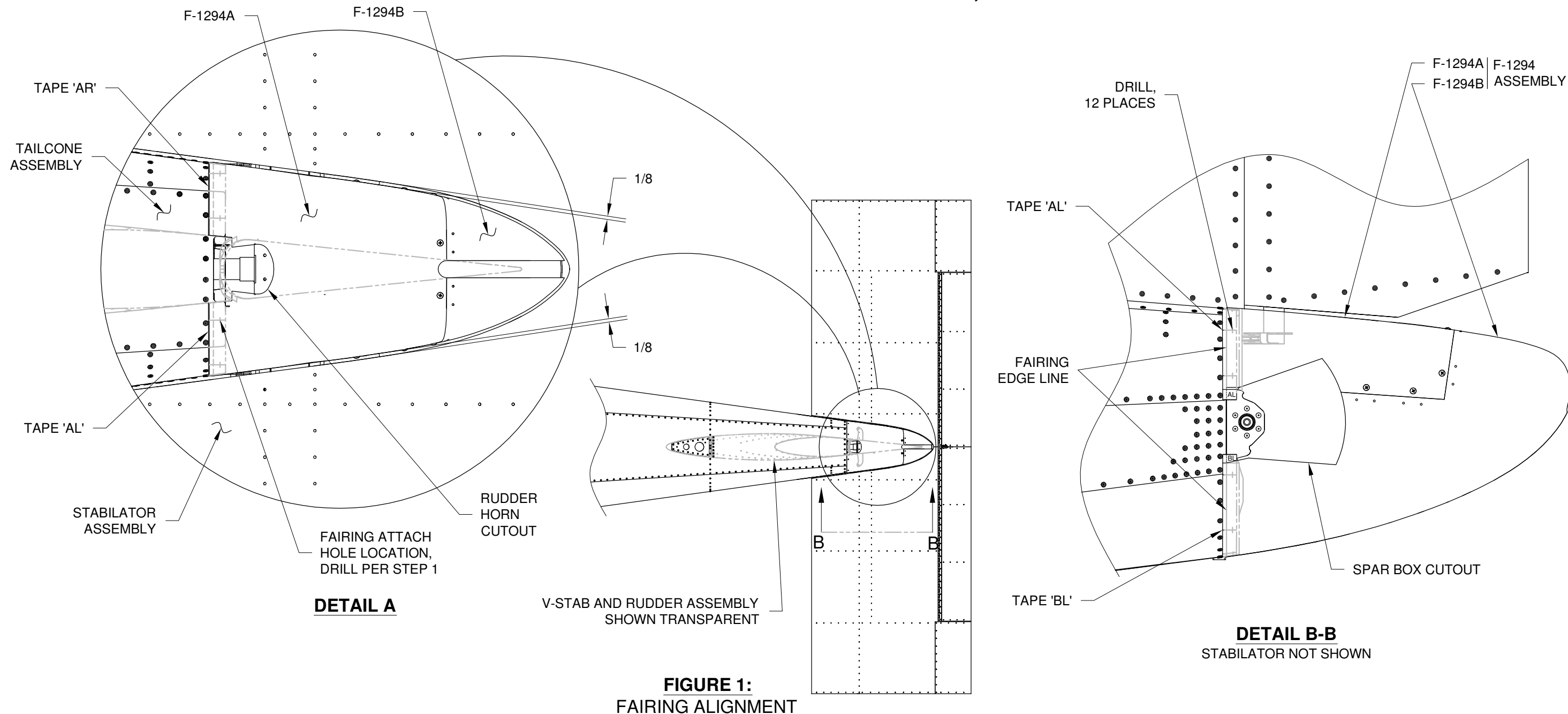
Remove F-1294 Assembly, deburr holes and clear away loose material. Re-cleco. Recheck clearance between the F-1294 Assembly and the Rudder and Stabilator Assemblies.

**Step 7:** Final-Drill with modified #27 (Ref Page 12-07) the holes common to the F-1294 Assembly and the Tailcone Assembly. Cleco as you go.

Remove F-1294 Assembly, deburr holes and clear away loose material. Re-cleco.

**Step 8:** Check the clearance between the F-1294 Assembly spar box cutout and the Stabilator Assembly spar box throughout the full travel of the Stabilator Assembly as shown in Figure 1, Detail B-B. Check the clearance between the F-1294 Assembly rudder horn cutout and the rudder horn throughout the full travel of the Rudder Assembly as shown in Figure 1, Detail A. Mark, and trim any areas of interference for at least 1/8 inch of clearance to the F-1294 Assembly.

Remove the F-1294 Assembly.



**FIGURE 1:**  
FAIRING ALIGNMENT



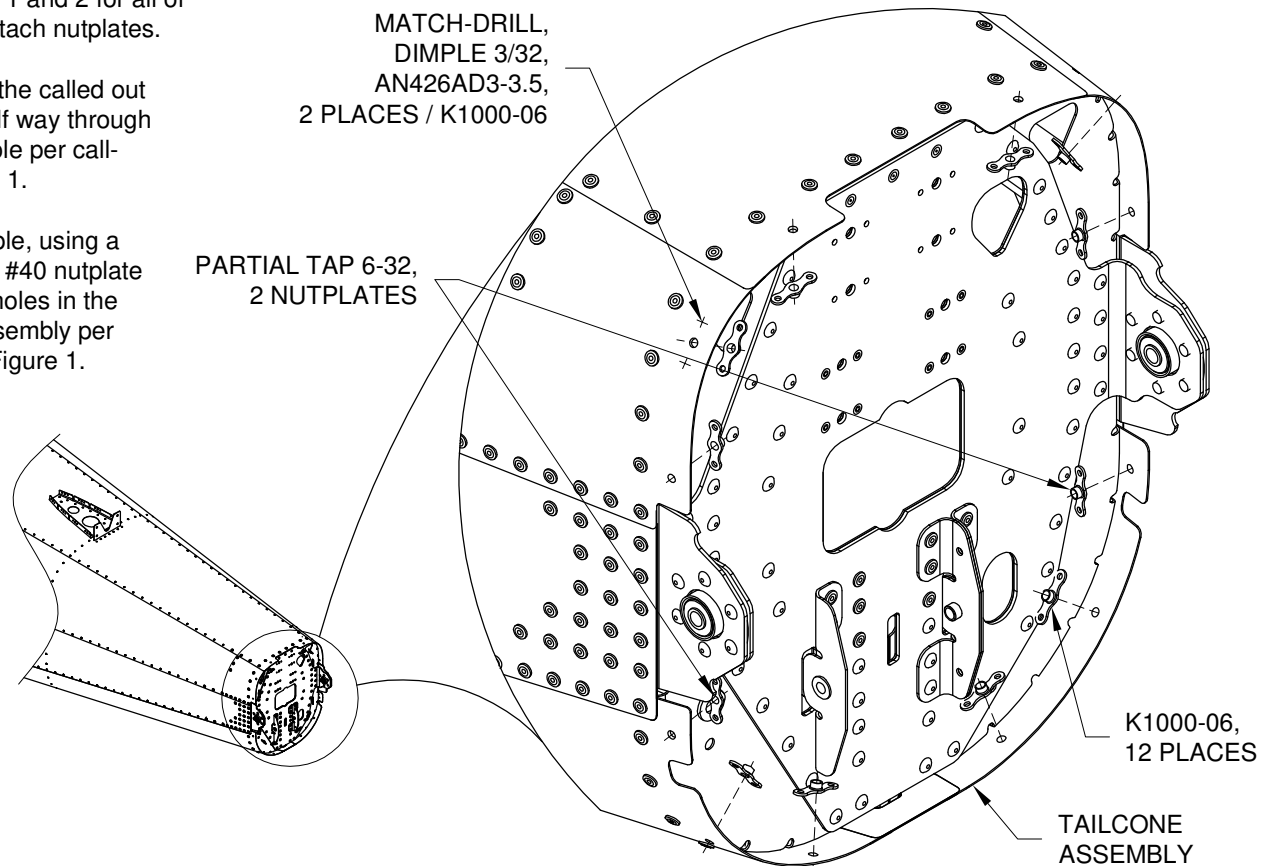
**Step 1:** Locate a nutplate, using a #6 screw, through one of the #27 fairing attach holes in the aft of the Tailcone Assembly. Bend the nutplate attach tabs as necessary to conform to the tailcone skins.

**Step 2:** Match-Drill using an extended #40 one of the nutplate attach rivet holes into the Tailcone Assembly. Cleco that hole. Then match-drill #40 the remaining nutplate attach rivet hole. Mark the location of each nutplate.

Repeat Step 1 and 2 for all of the fairing attach nutplates.

**Step 3:** Tap the called out nutplates half way through the screw hole per call-out in Figure 1.

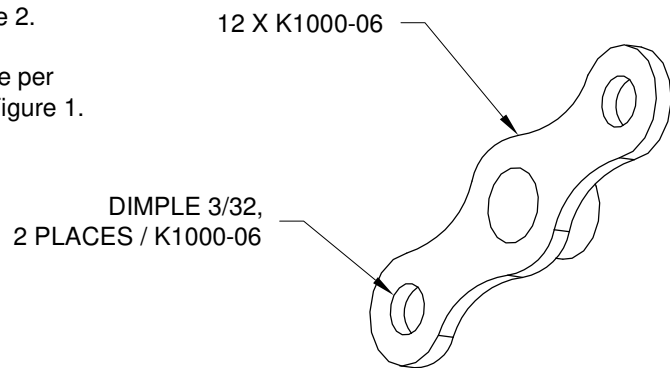
**Step 4:** Dimple, using a 3/32 die, the #40 nutplate attach rivet holes in the Tailcone Assembly per call-outs in Figure 1.



**FIGURE 1:**  
FAIRING ATTACH NUTPLATES

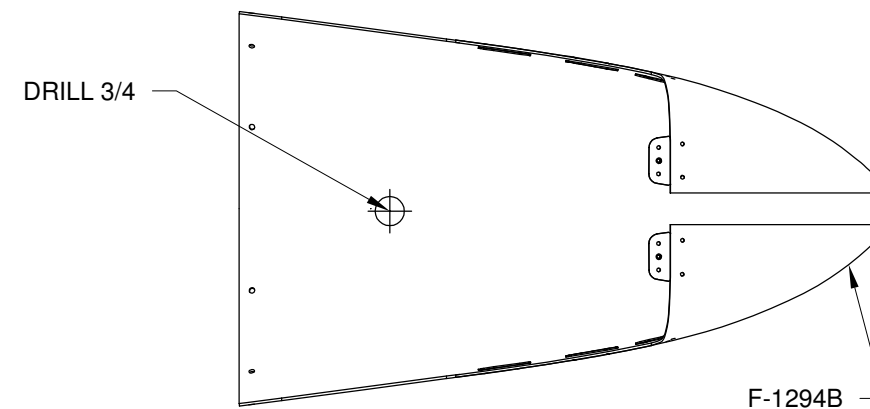
**Step 5:** Dimple, using a 3/32 die, the attach rivet holes in the nutplates called out in Figure 2.

**Step 6:** Rivet the nutplates to the tailcone per marks made in Step 2, and call-outs in Figure 1.



**FIGURE 2:**  
NUTPLATE PREPARATION

**Step 7:** Drill a 3/4 hole using a step drill bit within the scribe line at the bottom of the F-1294B Lower Tailcone Fairing as shown in Figure 3.



**FIGURE 3:**  
TRIM/SERVO LINKAGE HOLE

**Step 8:** Install the Trim/Servo Assembly. Refer to Section 11, Page 7 for attachment instructions.

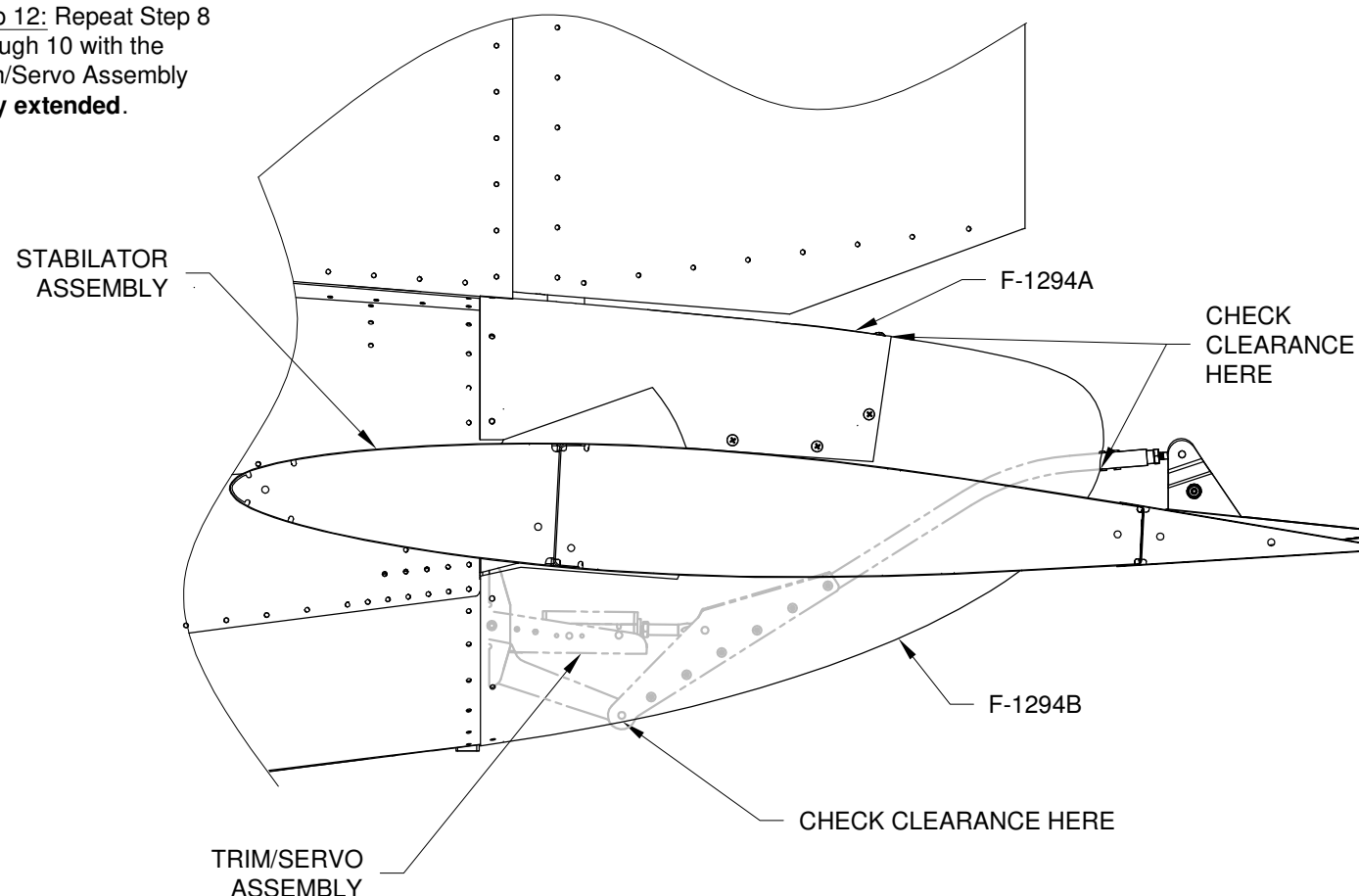
**Step 9:** Refer to Page 11-08 for temporary Trim/Servo Assembly actuation instructions. Actuate the Trim/Servo Assembly to be fully retracted.

**Step 10:** Attach the F-1294A & B Upper and Lower Tailcone Fairings to the Tailcone Assembly.

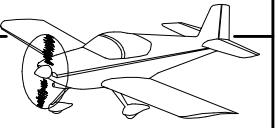
**Step 11:** Check the clearance between the Trim/Servo Assembly and the F-1294A & B Upper and Lower Tailcone Fairing throughout the Stabilator Assembly travel as shown in Figure 4. If necessary, mark then trim the upper and lower tailcone fairings to provide at least 1/8 inch of clearance for the Trim/Servo Assembly.

Remove the upper and lower tailcone fairings.

**Step 12:** Repeat Step 8 through 10 with the Trim/Servo Assembly fully extended.

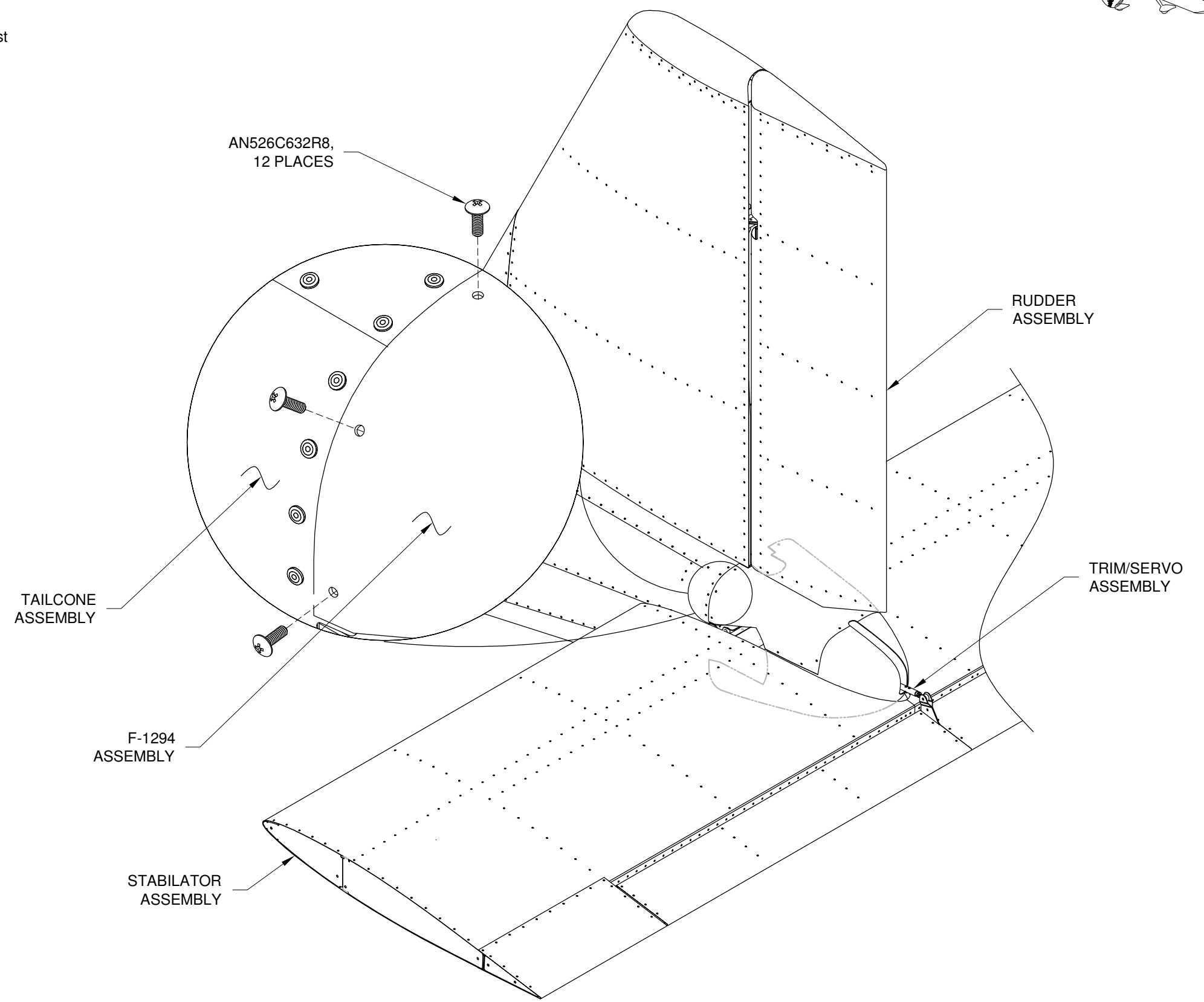


**FIGURE 4:**  
TRIM/SERVO CLEARANCE



Step 1: Install the F-1294A & B Upper and Lower Tailcone Fairing to the Tailcone Assembly using screws called out in Figure 1.

Step 2: Re-check the clearance throughout the travel of the Rudder, Stabilator and Trim/Servo Assemblies to the F-1294A & B Upper and Lower Tailcone Fairings. At least 1/8 inch of clearance is needed.



**FIGURE 1:**  
FAIRING INSTALLATION



**THIS PAGE INTENTIONALLY LEFT BLANK**