

SECTION 25: MID FUSE BULKHEADS

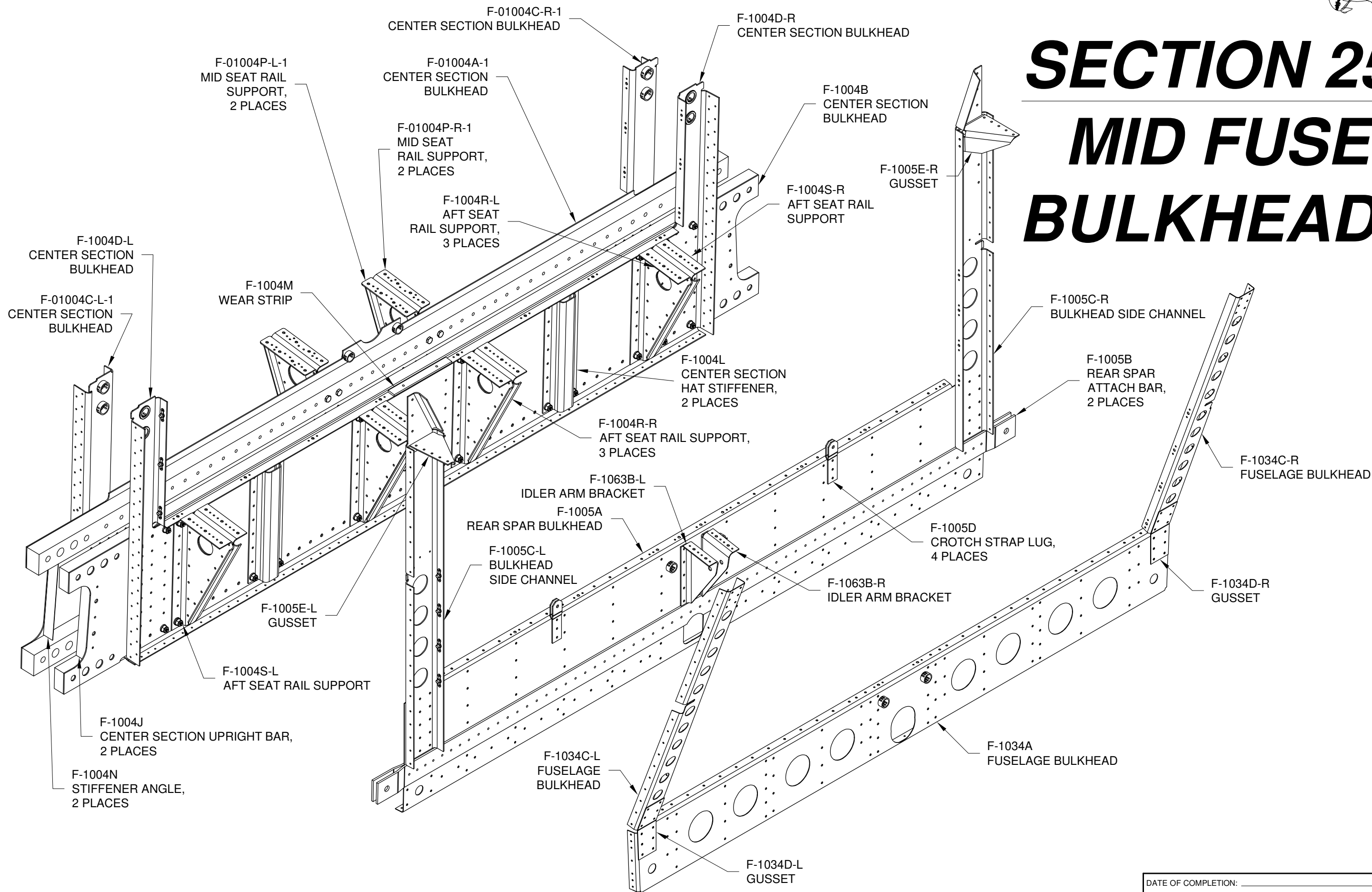



Step 1: Create two F-1004N Stiffener Angles from AA6-063X3/4X3/4 per the dimensions given in Figure 1.

Step 2: Mark a centerline on one outside face of each F-1004N Stiffener Angle, see Figure 2.

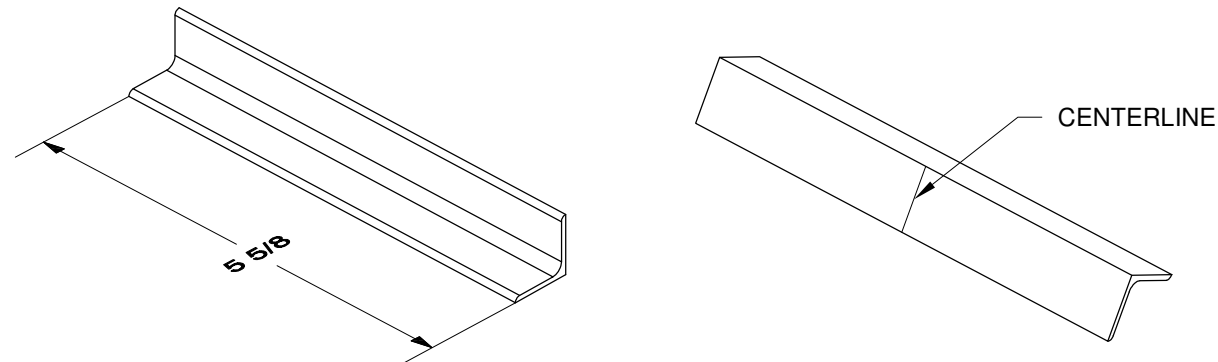

FIGURE 1: CREATING STIFFENER ANGLES **FIGURE 2: MARKING STIFFENER ANGLES**

Step 3: Clamp a F-1004N Stiffener Angle to the F-01004A-1 Center Section Bulkhead as shown in Figure 3. Align the edge of the angle with the outboard edge of the bulkhead as shown in Figure 3. Center the centerline in the center hole of the bulkhead. Clamp both parts together.

Step 4: Match-Drill #30 the five holes of the F-01004A-1 Center Section Bulkhead into the F-1004N Stiffener Angle using the center section bulkhead as a drill guide. Cleco each hole as it is drilled. Repeat this step for the remaining stiffener angle.

Step 5: Remove the F-1004N Stiffener Angles from the F-01004A-1 Center Section Bulkhead and deburr the edges on all parts.

Prime the stiffener angles.

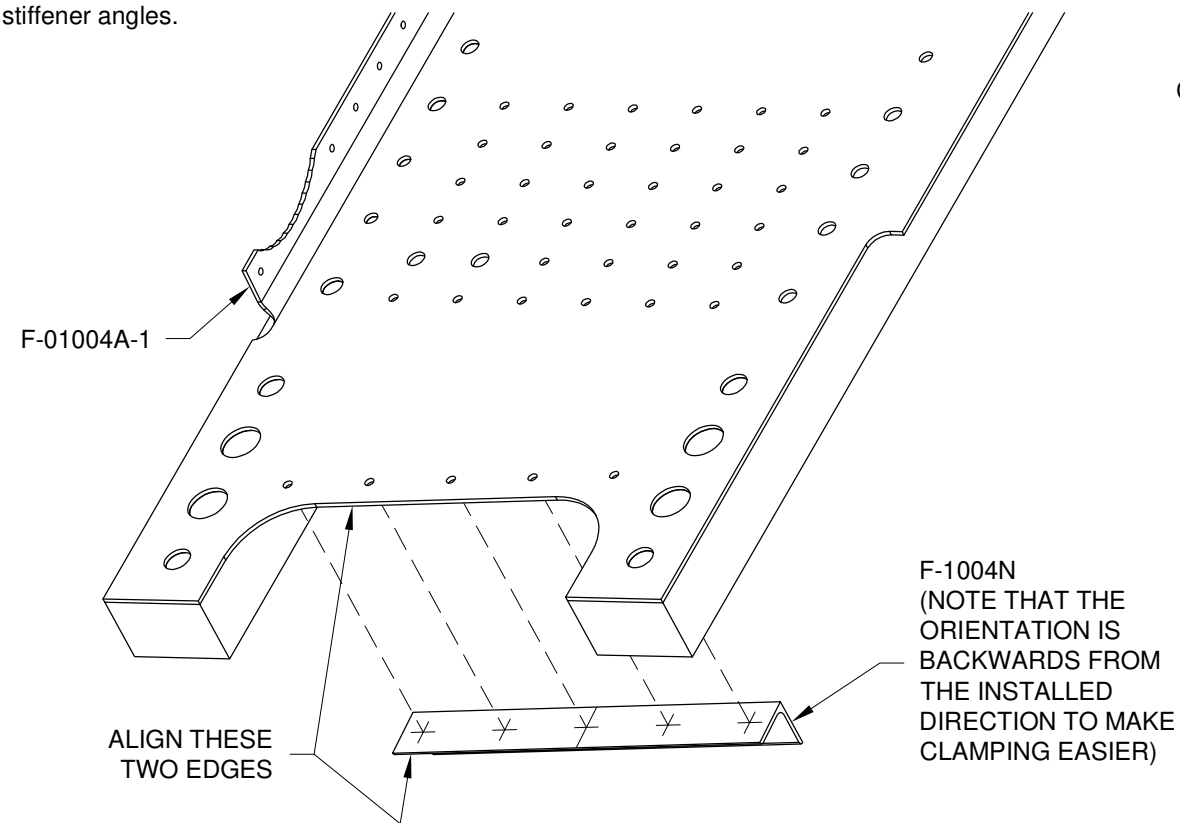

FIGURE 3: MATCH-DRILLING STIFFENER ANGLES

Step 6: There are three nutplate attach patterns in the inboard flange of the F-01004C-L-1 & -R-1 Center Section Bulkheads. Machine countersink the screw holes for the lower two nutplates for the head of an #8 screw (see Figure 4).

Step 7: Cleco the F-01004P-L-1 & -R-1 Mid Seat Rail Supports and F-01004C-L-1 & -R-1 Center Section Bulkheads to the F-01004A-1 Center Section Bulkhead as shown in Figure 4.

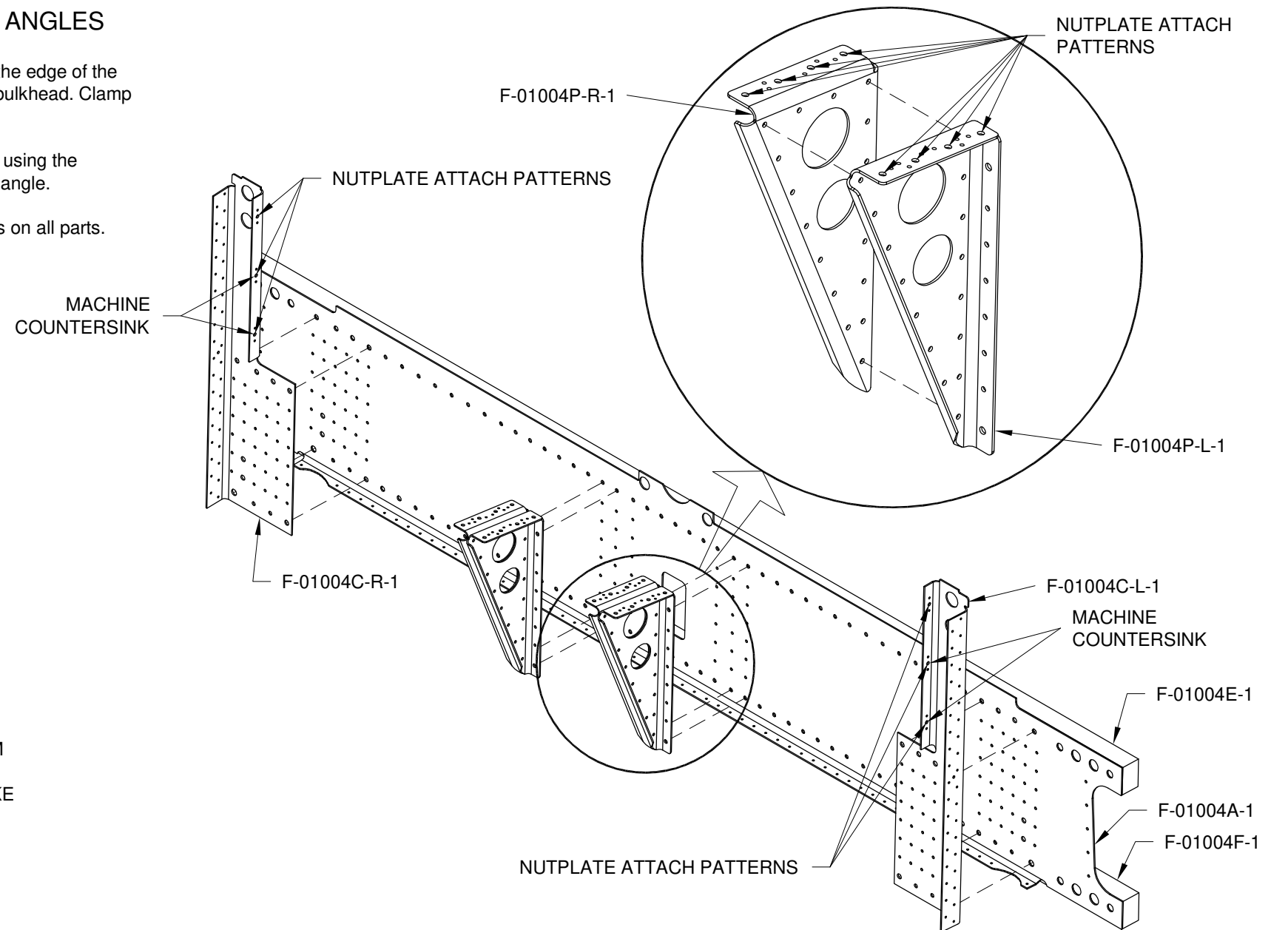
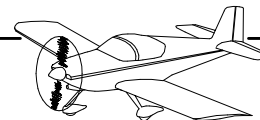

FIGURE 4: DRILLING THE FWD CENTER SECTION ASSEMBLY



Step 1: Temporarily bolt the WD-01021-L-1 Landing Gear Mount Left to the Fwd Center Section Bulkhead Assembly as shown in Figure 2. This will require trimming the outboard portion of the fwd center section bulkhead lower flange to remove interference with the gear leg socket as shown in Figure 1. Figure 1 gives only the general idea of how the final trim will look and is not a final trim template. Trim the fwd center section bulkhead progressively using the landing gear mount left as a guide. Repeat for the WD-01021-R-1 Landing Gear Mount Right.

Step 2: Temporarily bolt the WD-01021-L-1 & -R-1 Landing Gear Mounts to the Fwd Center Section Bulkhead Assembly and check that an AN3 Bolt will pass through all parts. Remove the landing gear mounts from the bulkhead assembly and deburr or ream as required.

Step 3: Machine countersink two places each (left/right) side as shown in Figure 2 to fit the head of a #10 screw.

Step 4: Disassemble all the parts in the Fwd Center Section Bulkhead Assembly and deburr all edges. Machine countersink all the nutplate attach holes for the head of an AN426AD3 rivet. Prime parts if/as desired.

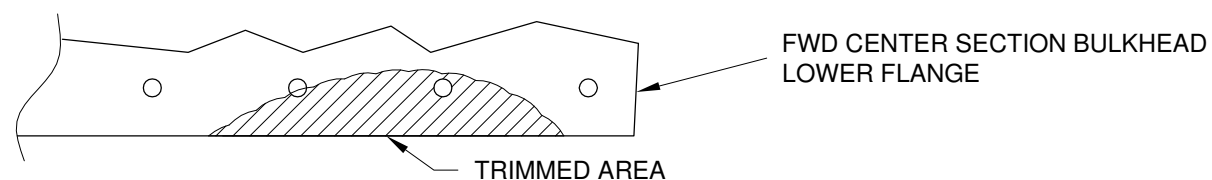

FIGURE 1: TRIMMING THE FWD CENTER SECTION BULKHEAD LOWER FLANGE

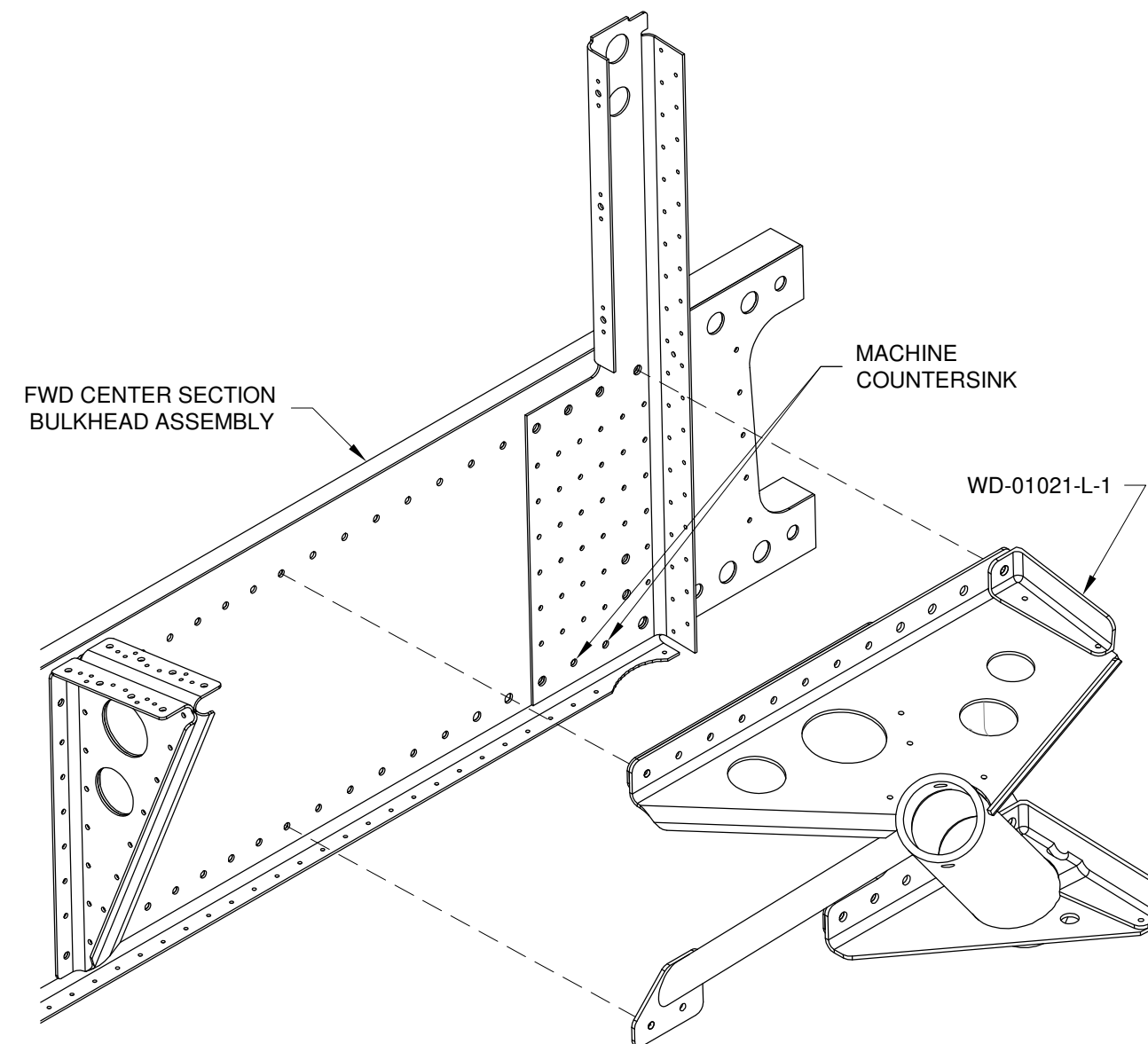
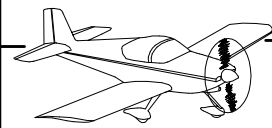

FIGURE 2: TEMP BOLT LANDING GEAR MOUNT TO FORWARD CENTER SECTION BULKHEAD ASSEMBLY



Step 1: Cleco the F-01004P-L-1 & -R-1 Mid Seat Rail Support together as shown in Figure 1. Rivet the F-01004P-L-1 and -R-1 Mid Seat Rail Support together per the callouts in Figure 1. Repeat this step to create two Mid Seat Rail Support Subassemblies.

Step 2: Cleco then rivet the nutplates onto the upper flanges of both Mid Seat Rail Support Subassemblies as shown in Figure 1. Repeat this step on both Mid Seat Rail Support Subassemblies.

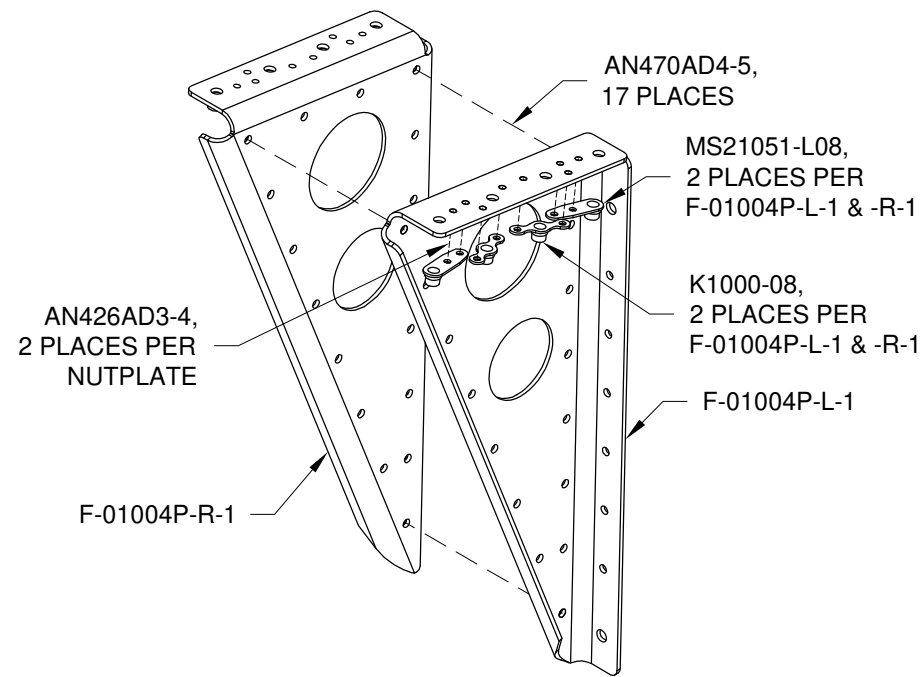

FIGURE 1: RIVETING THE MID SEAT RAIL SUPPORT SUBASSEMBLIES

Step 3: Rivet the nutplates onto the inboard flange of the F-01004C-L-1 & -R-1 Center Section Bulkheads per the callouts in Figure 2.

Step 4: Cleco the Mid Seat Rail Support Subassemblies, F-01004C-L-1 & -R-1 Center Section Bulkheads and F-1004N Stiffener Angles to the F-01004A-1 Center Section Bulkhead.

Step 5: Bolt the Mid Seat Rail Support Subassemblies to the F-01004A-1 Center Section Bulkhead per the callouts in Figure 2. Install two screws on each side of the fwd center section assembly as shown in Figure 2.

Step 6: Rivet the Mid Seat Rail Support Subassemblies, F-01004C-L-1 & -R-1 Center Section Bulkheads and F-1004N Stiffener Angles to the F-01004A-1 Center Section Bulkhead per the callouts in Figure 2.

Step 7: Insert snap bushings into the F-01004C-L-1 & -R-1 Center Section Bulkheads per the callouts in Figure 2.

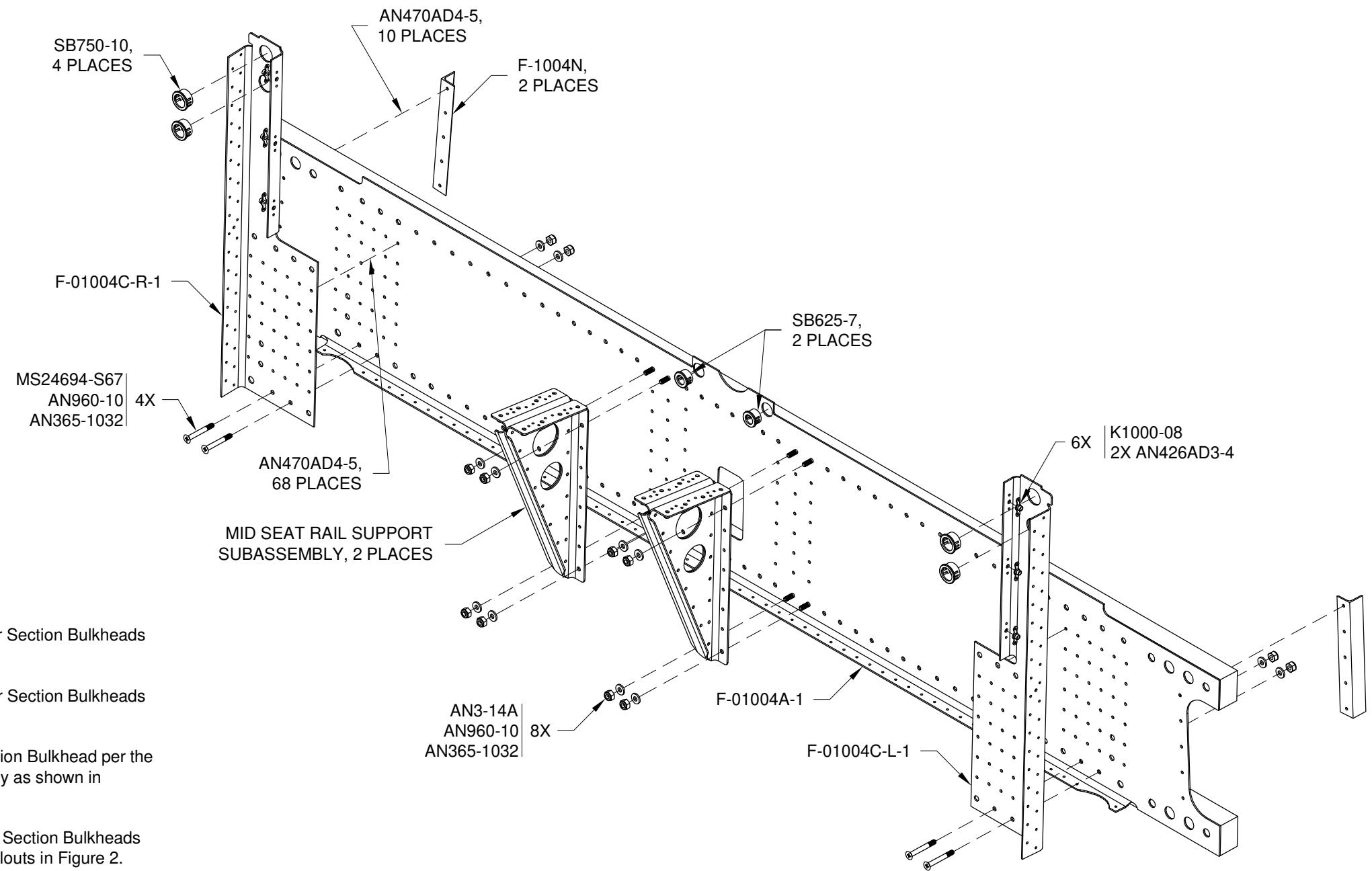
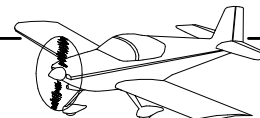

FIGURE 2: RIVETING THE FWD CENTER SECTION BULKHEAD ASSEMBLY



Step 1: Cleco the F-1004S-L and -R and the F-1004R-L and -R Aft Seat Rail Supports together as shown in Figure 1 and called out in Figure 2 to create four Aft Seat Rail Support Subassemblies. Final-Drill #30 all the holes common between both parts in all four subassemblies. Final-Drill #40 the nutplate attach holes and #19 all the screw holes in the upper flanges of all the aft seat rail supports.

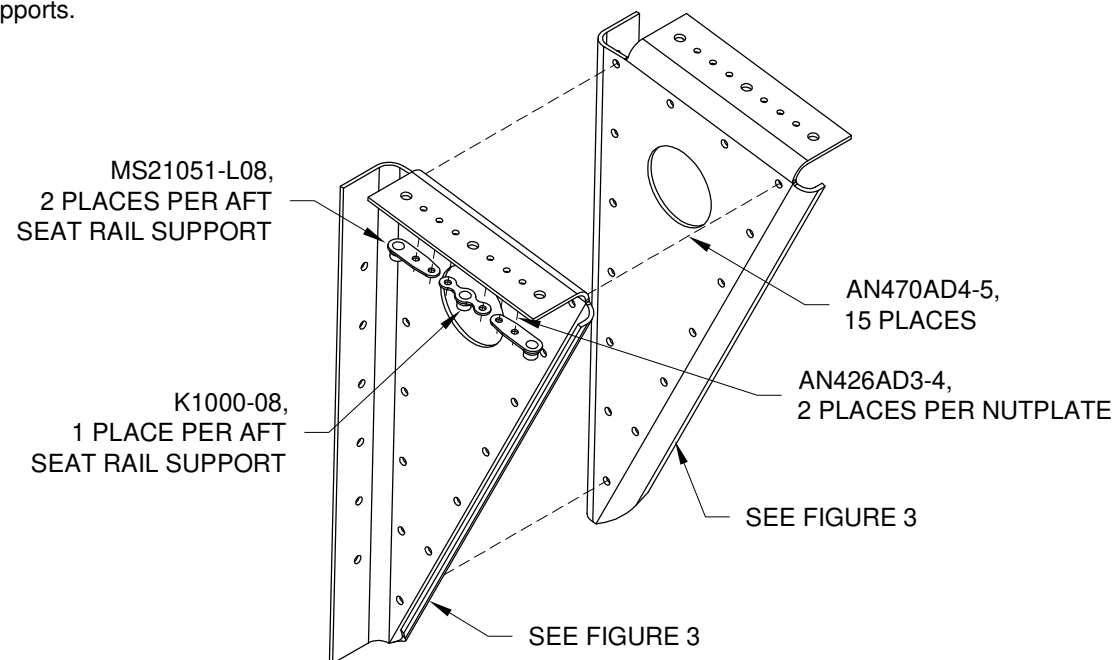

FIGURE 1: TYPICAL AFT SEAT RAIL SUPPORT SUBASSEMBLY

Step 2: Final-Drill #40 the nutplate attach holes and #19 the screw holes in the upper flange of the F-1004B Center Section Bulkhead and the inboard flanges of the F-1004D-L and -R Center Section Bulkheads. Machine countersink the screw holes for the lower two nutplates in the inboard flange of the center section bulkheads for the head of an #8 screw (see Figure 3).

Step 3: Cut the F-1004L Hat Stiffener apart as shown in Figure 2 to form two F-1004L Hat Stiffeners. Trim the hatched area from either end of the hat stiffener as required to allow access to buck the rivets on the lower flange of the F-1004B Center Section Bulkhead.

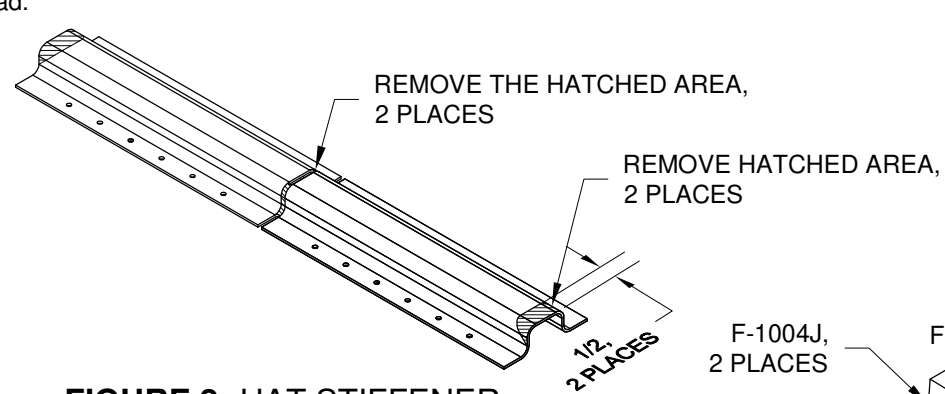

FIGURE 2: HAT STIFFENER

Step 4: Cleco the Aft Seat Rail Support Subassemblies, F-1004D-L and -R Center Section Bulkheads and F-1004L Center Section Hat Stiffeners to the F-1004B Center Section Bulkhead.

Step 5: Final-Drill #30 all holes common between the F-1004B Center Section Bulkhead and the Aft Seat Rail Support Subassemblies, F-1004D-L and -R Center Section Bulkheads and F-1004L Center Section Hat Stiffeners. Note that only one flange of the center section hat stiffeners have holes and the other is blank. Match-Drill #30 the holes from the center section bulkhead into the hat stiffener.

Step 6: Match-Drill #12 all holes common between the F-1004B Center Section Bulkhead, F-1004G and F-1004H Center Section Bars and the Aft Seat Rail Support Subassemblies, F-1004D-L and -R Center Section Bulkheads and F-1004L Center Section Hat Stiffeners. Mark the seat rail support subassemblies so they can return to the same position.

Step 7: Align the F-1004J Center Section Upright Bars with the F-1004B Center Section Bulkhead using two AN4 bolts. Final-Drill #30 the three 1/8 inch holes that attach both center section upright bars to the center section bulkhead. Mark the upright bars forward side so they can be returned to the same position.

Step 8: Disassemble the aft center section bulkhead assembly and deburr all edges. Enlarge the snap bushing pilot holes as indicated in Figure 3 to 3/4 diameter. Machine countersink the all nutplate attach holes for the head of an AN426AD3 rivet. Machine countersink the #30 holes on the forward side of the F-1004J Center Section Upright Bars for the head of an AN426AD4 rivet. Prime the center section upright bars. Prime the remaining parts if/as desired.

Step 9: Cleco then rivet the four Aft Seat Rail Support Subassemblies together per the callouts in Figure 1. Rivet nutplates to the upper flanges of the aft seat rail support subassemblies as shown in Figure 1.

Step 10: Reassemble the bulkhead per Step 4. Align the F-1004J Center Section Upright Bars with the F-1004B Center Section Bulkhead using two AN4 bolts.

Step 11: Rivet the F-1004J Center Section Upright Bars to the F-1004B Center Section Bulkhead per the callouts in Figure 3.

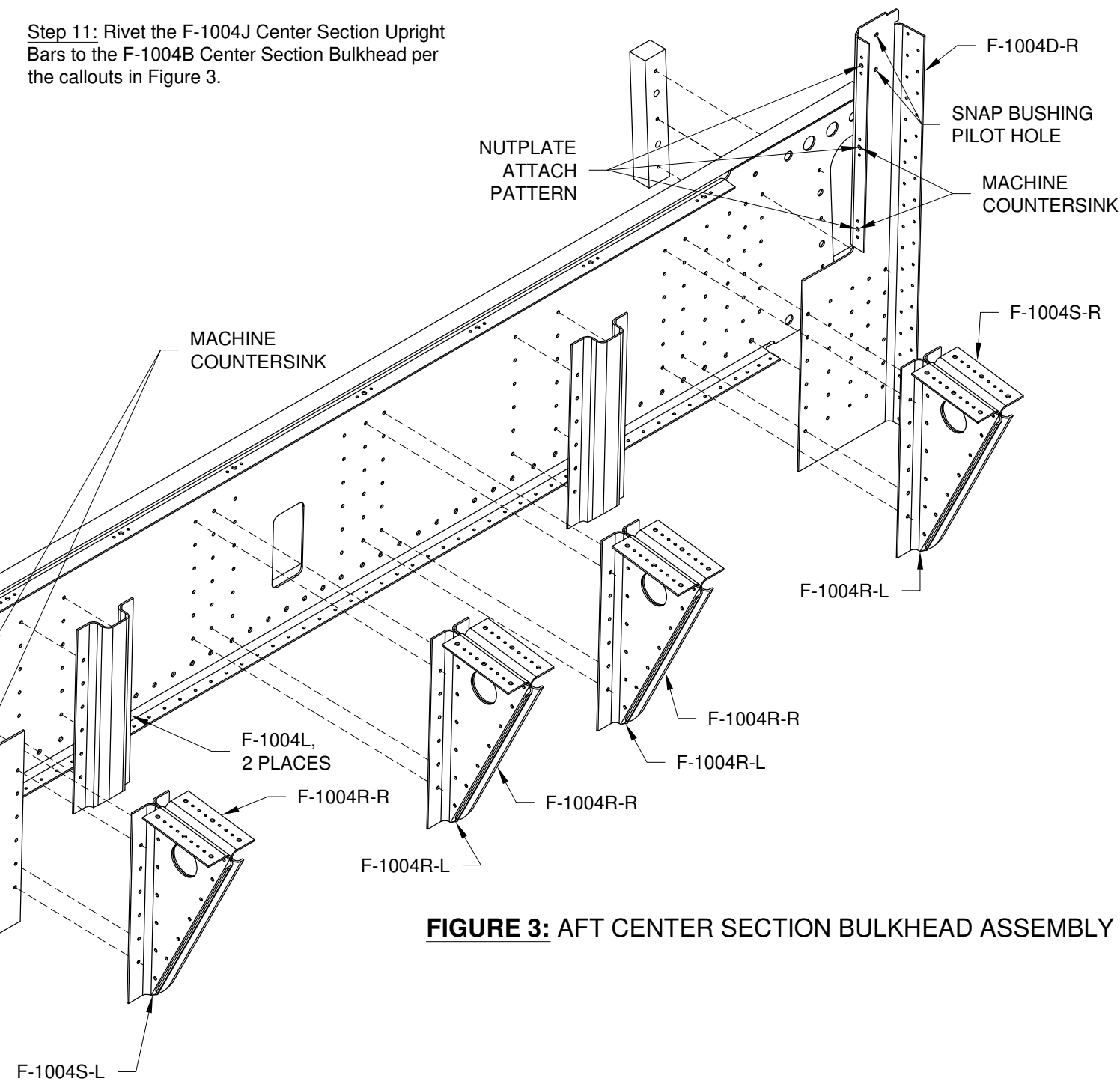
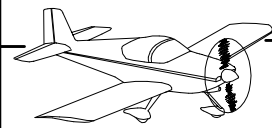

FIGURE 3: AFT CENTER SECTION BULKHEAD ASSEMBLY



Step 1: Rivet nutplates to the F-1004B, F-1004D-L and -R Center Section Bulkheads as shown in Figure 2.

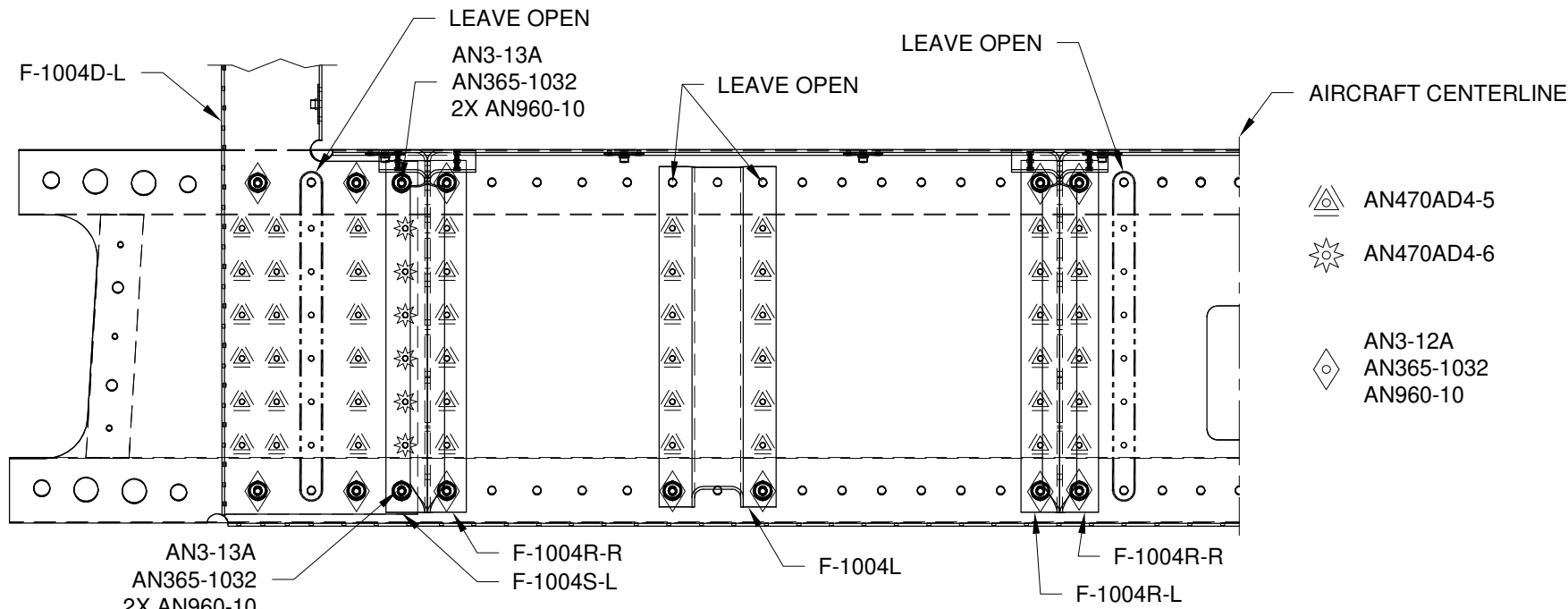

FIGURE 1: AFT BULKHEAD HARDWARE
(CALLOUTS ARE FOR THE LEFT SIDE OF THE AIRCRAFT
CALLOUTS ARE SYMMETRICAL ABOUT
THE AIRCRAFT CENTERLINE)

Step 2: Bolt the Aft Seat Rail Support Subassemblies, F-1004D-L and -R Center Section Bulkheads and F-1004L Center Section Hat Stiffeners to the F-1004B Center Section Bulkhead as shown in Figure 2.

Step 3: Rivet the F-1004D-L and -R Center Section Bulkheads, F-1004L Center Section Hat Stiffeners and Aft Seat Rail Support Subassemblies to the F-1004B Center Section Bulkhead as shown in Page 25-5, Figure 3 and per the callouts in Figure 1.

Step 4: Insert snap bushings into the F-1004D-L and -R Center Section Bulkheads as shown in Figure 2.

Step 5: Fabricate the F-1004M Wear Strip by cutting a piece of 1/8 inch thick by 1/2 inch wide UHMW plastic to 4 3/4 inches long. The wear strip may be up to 1/32 inch short but must not be over length.

Drill two #30 holes centered on the width of the wear strip, each one 1 inch from the end.

Step 6: Clamp the F-1004M Wear Strip to the upper flange of the F-1004B Center Section Bulkhead.

Position the wear strip such that the aft edge of the wear strip is flush with the center section bulkhead upper flange aft edge and such that the wear strip is exactly centered on the center section bulkhead upper flange.

Match-drill two #30 holes through the center section bulkhead upper flange using the holes in the wear strip as drill guides. Remove the wear strip and deburr the holes in the center section bulkhead.

Step 7: Rivet the F-1004M Wear Strip to the upper flange of the F-1004B Center Section Bulkhead as shown in Figure 2.

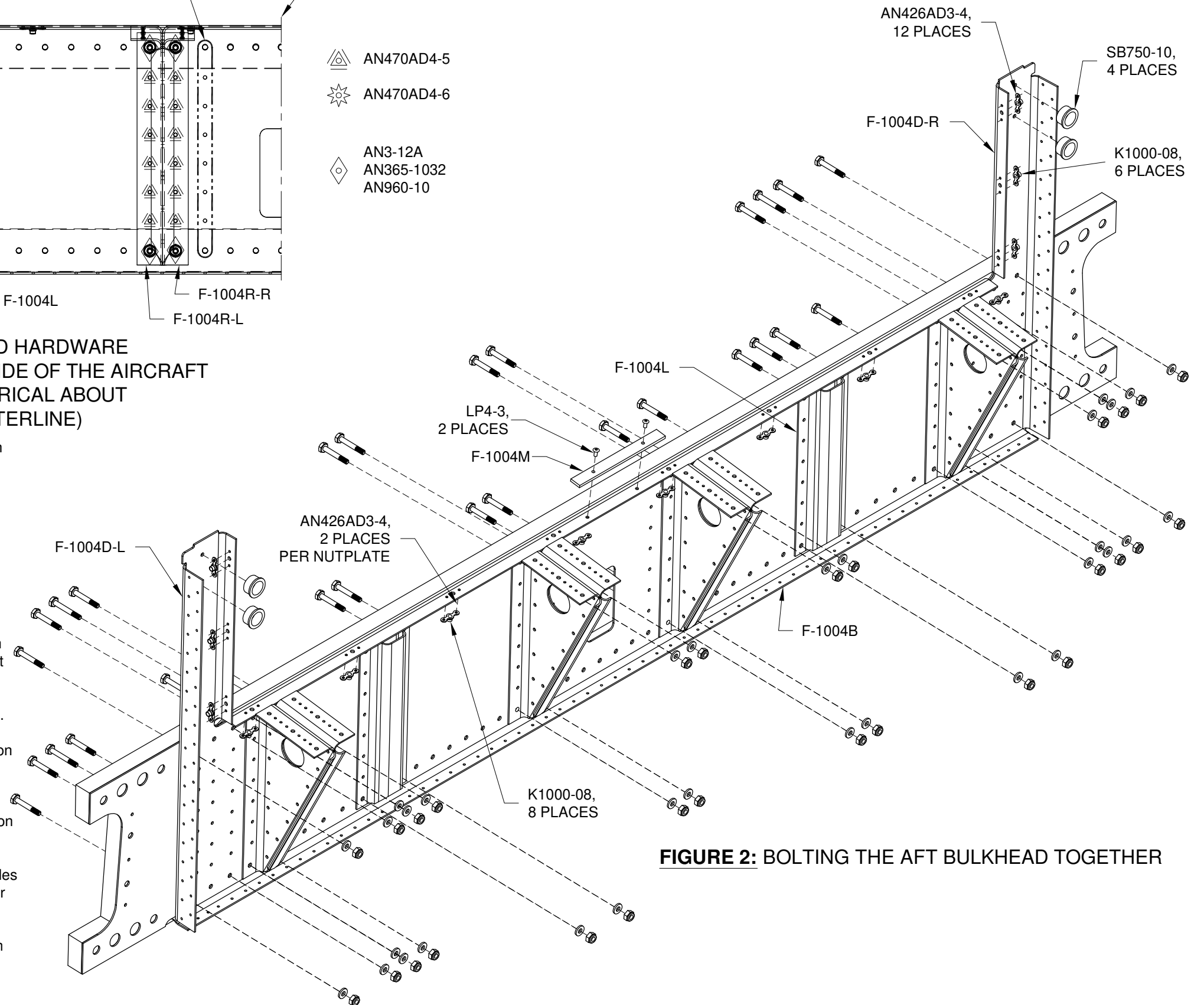

FIGURE 2: BOLTING THE AFT BULKHEAD TOGETHER



Step 1: Final-Drill #40 all the nutplate attach holes and #19 all the nutplate screw holes in the F-1005A Rear Spar Bulkhead, F-1005C-L and -R Bulkhead Side Channel and F-1063B-L and -R Idler Arm Brackets as shown in Figure 2.

Step 2: Cleco the F-1005B Rear Spar Attach Bars, F-1005C-L and -R Bulkhead Side Channels, F-1005D Crotch Strap Lugs, F-1005E-L and -R Gussets and F-1063B-L and -R Idler Arm Brackets to the F-1005A Rear Spar Bulkhead, as shown in Figure 2. Using Figure 1 as a guide tape over or mark the holes to be left open. Final-Drill #30 the remaining holes common between the parts just clecoed together.

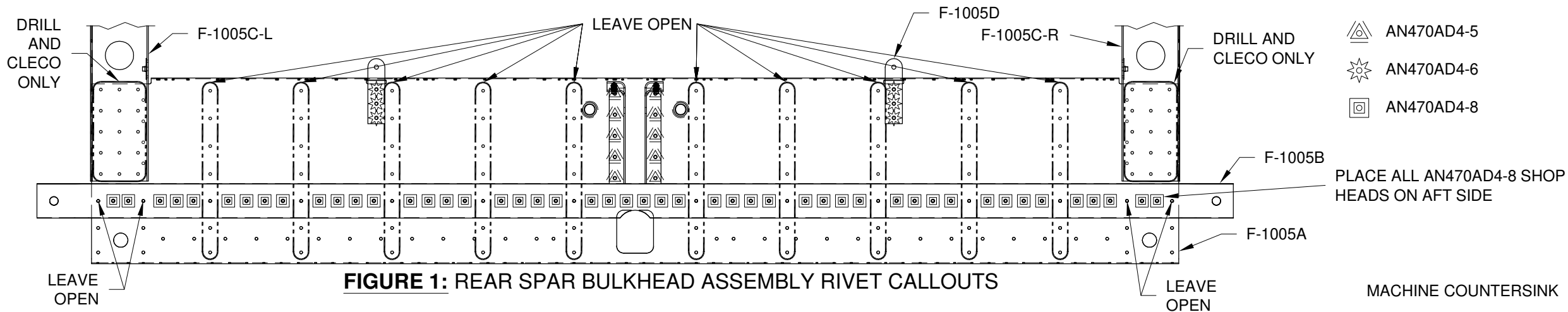

FIGURE 1: REAR SPAR BULKHEAD ASSEMBLY RIVET CALLOUTS

Step 3: Disassemble and deburr all the bulkhead parts. Machine countersink the nutplate attach holes in the F-1005C-L and -R Bulkhead Side Channels and F-1063B-L and -R Idler Arm Brackets for the head of an AN426AD3 rivet. Machine countersink the forward and inboard face of the bulkhead side channels for all the F-1005E-L and -R Gusset attach holes. Machine countersink the three lower screw holes in the inboard flange of the bulkhead side channels for the head of an #8 screw (see Figure 2). Prime parts if/as desired.

Step 4: Rivet the nutplates onto the F-1005C-L and -R Bulkhead Side Channel and F-1063B-L and -R Idler Arm Brackets as shown in Figure 2. **Do not rivet nutplates onto the upper flange of the F-1005A Rear Spar Bulkhead.**

Step 5: Rivet the F-1005B Rear Spar Attach Bars, F-1005D Crotch Strap Lugs and F-1063B-L and -R Idler Arm Brackets to the F-1005A Rear Spar Bulkhead per the callouts in Figure 1 and Figure 2.

Step 6: Rivet the F-1005E-L Gusset to the F-1005C-L Bulkhead Side Channel per the callouts in Figure 2. Rivet the F-1005E-R Gusset to the F-1005C-R Bulkhead Side Channel per the callouts in Figure 2.

Step 7: Install snap bushings into the F-1005A Rear Spar Bulkhead as shown in Figure 2.

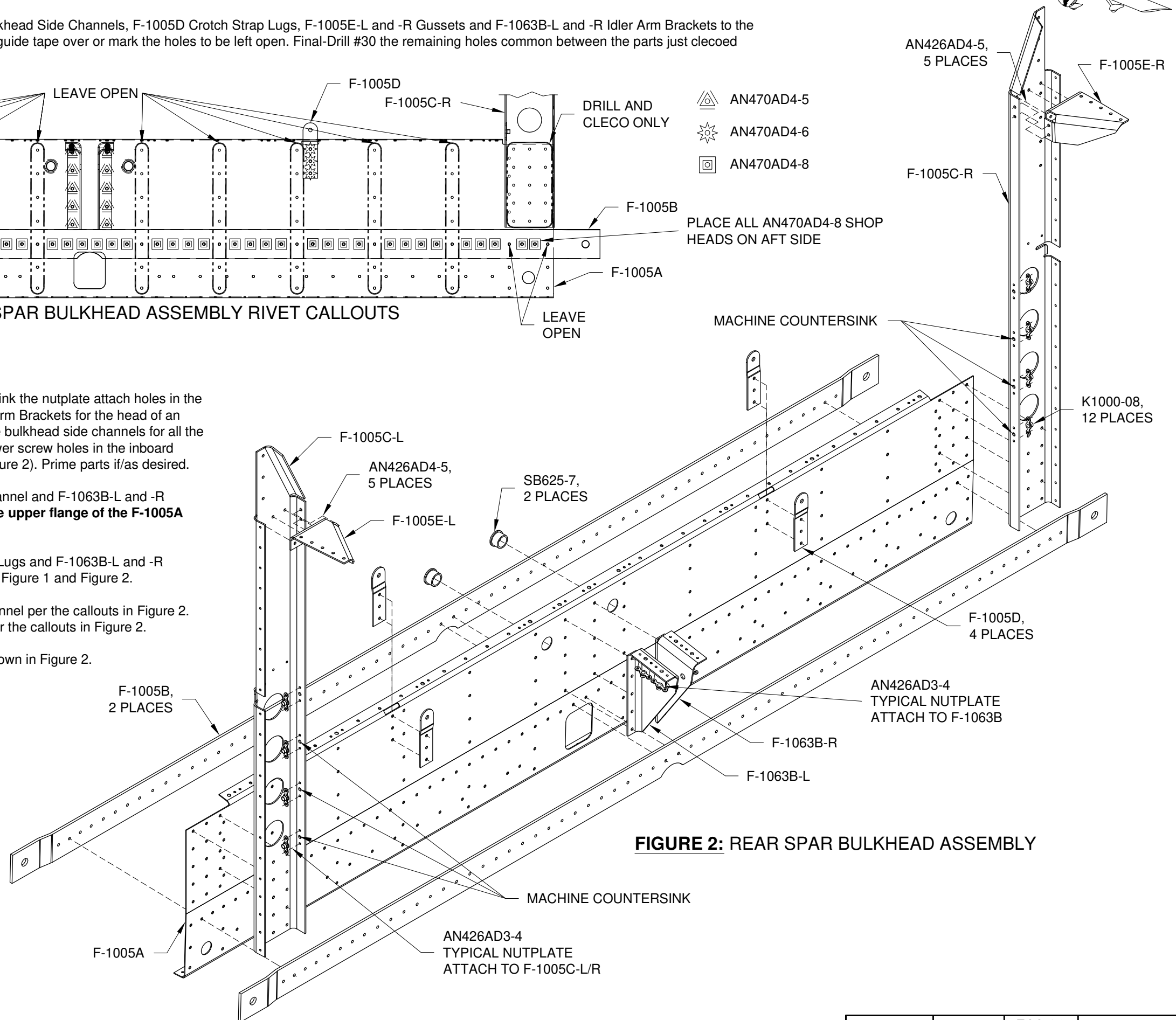

FIGURE 2: REAR SPAR BULKHEAD ASSEMBLY



Step 1: Cut the F-1034D-L and -R Gussets apart from one another as shown in Figure 1.

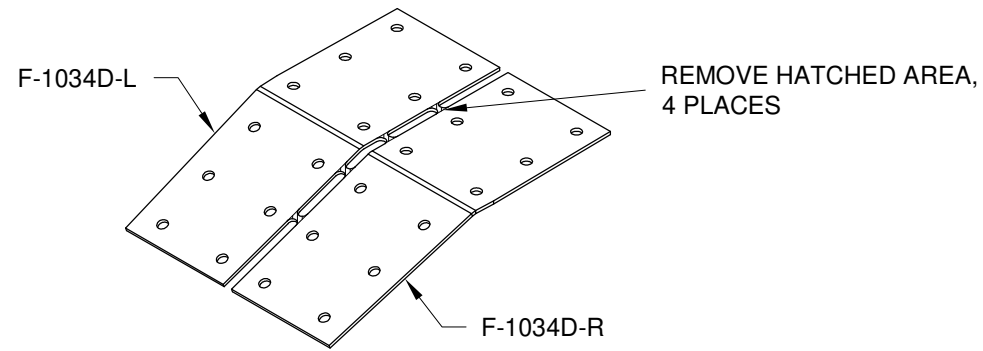

FIGURE 1: BREAKING APART THE GUSSETS

Step 2: Cleco the F-1034A Fuselage Bulkhead, F-1034C-L and -R Fuselage Bulkheads, and F-1034D-L and -R Gussets together as shown in Figure 2.

Step 3: Final-Drill #30 all holes common between the parts clecoed together in Step 2.

Step 4: Final-Drill the nutplate attach holes for both nutplates near the center of the F-1034A Fuselage Bulkheads upper flange. Final-Drill #19 the screw holes for these nutplates.

Step 5: Disassemble all parts and deburr all edges. Prime parts if/as desired.

Step 6: Rivet the F-1034D-L and -R Gussets to the F-1034A Fuselage Bulkhead per the callouts in Figure 2. To this subassembly rivet the F-1034C-L and -R Fuselage Bulkheads per the callouts in Figure 2.

Step 7: Install snap bushings into the F-1034A Fuselage Bulkhead as shown in Figure 2.

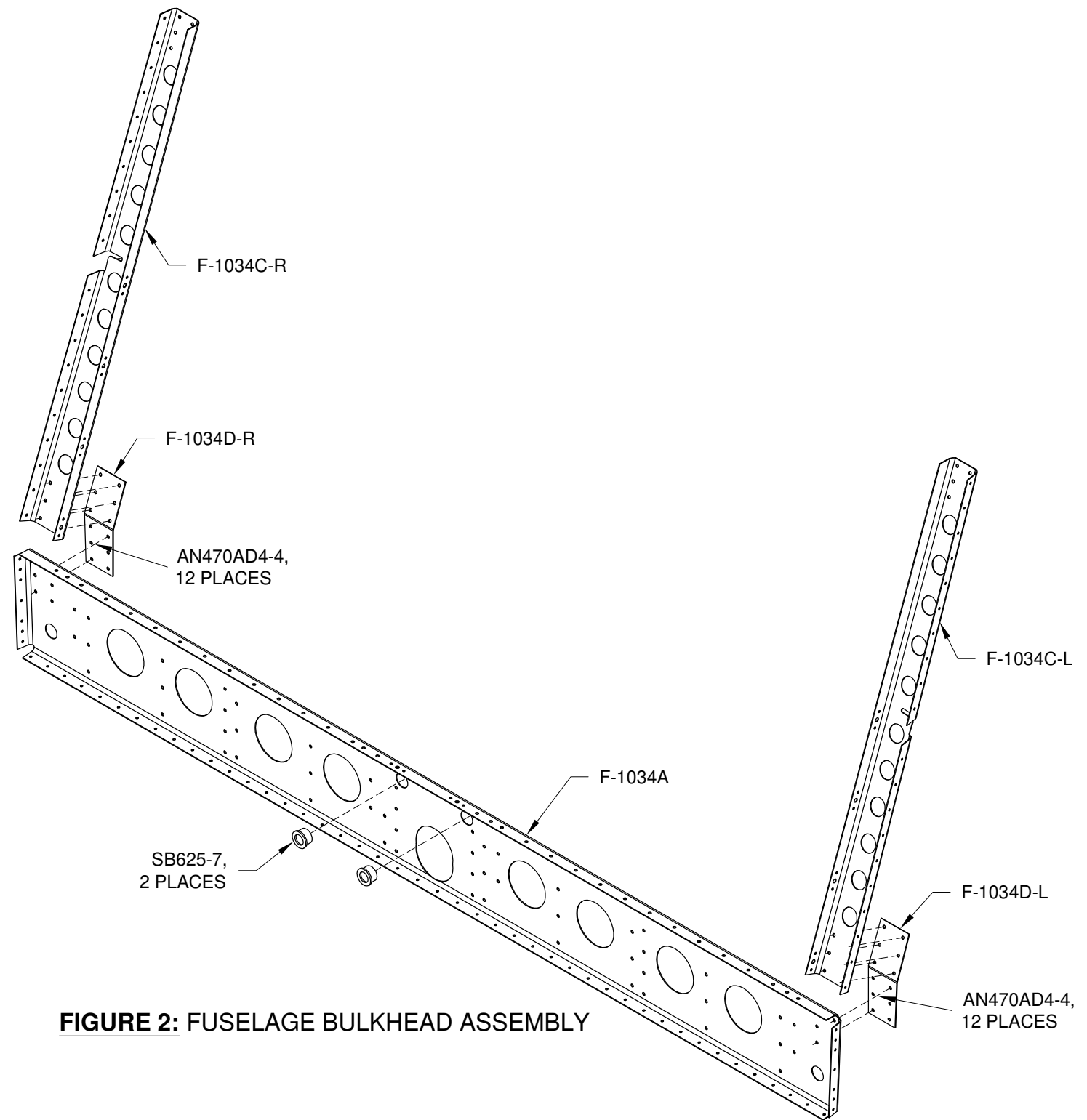

FIGURE 2: FUSELAGE BULKHEAD ASSEMBLY