

ENGINE IDENTIFICATION

Under the Van's Aircraft O.E.M. agreement with Textron Lycoming we sell five specific engine models and each of these engines falls under one of three different configurations:

1: O-235N2C (118 hp) / O-320D1A (160 hp) / O-360A1A (180 hp) each of which has common induction (vertical), cylinder type (parallel valve), mount style (dynafoal I), fuel metering (carbureted), and various displacements (cubic inches).

2: IO-360M1B (180 hp) which has horizontal induction, parallel valves, dynafoal I mount, Bendix fuel injection, and 360 cubic inches of cylinder displacement.

3: IO-360A1B6 (200 hp) which has horizontal induction, angle valves, dynafoal I mount, Bendix fuel injection, and 360 cubic inches of cylinder displacement.

Our motor mounts and cowls are manufactured to accommodate the engines we sell and our finish kit order forms reflect selections that help us to ensure the customer gets the correct components to complete his/her aircraft.

If you are buying a NEW Lycoming from Van's, we only need know which engine. However, **OTHER** suppliers of engines, either rebuilders or manufacturers of Lycoming clones, are capable of producing a wide variety of combinations of engines that either mimic the above models or have distinct variations from them. To help you in providing us with the information we need for these other engine suppliers, please combine the form below with your finish kit order. Without the attachment of the ENGINE IDENTIFICATION form, we will not be able to complete the finish kit order.

ENGINE IDENTIFICATION

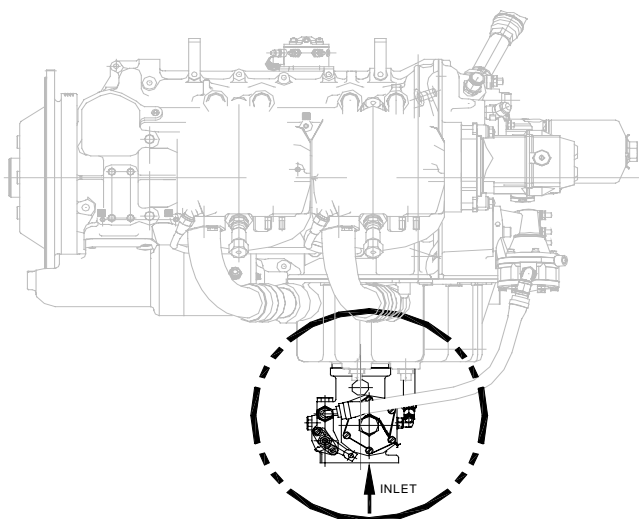

VERTICAL INDUCTION

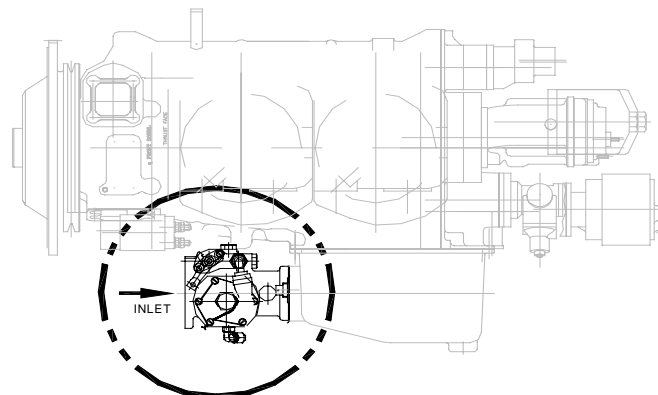

HORIZONTAL INDUCTION

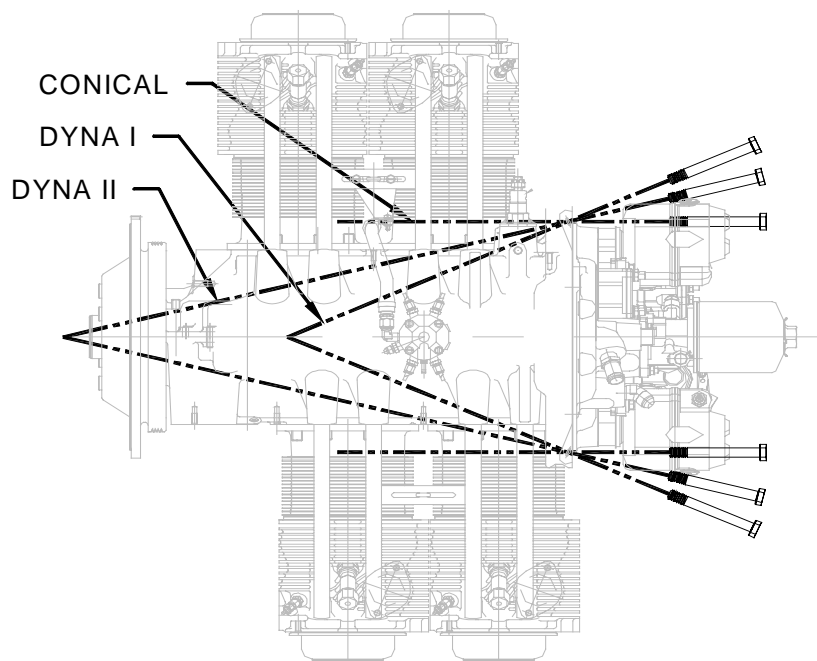

ENGINE MOUNT STYLE

VALVE COVER SHAPE



ANGLE VALVE

EXAMPLE:
IO-360 A1B6 (200 HP)

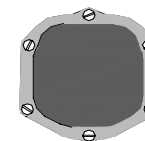

PARALLEL VALVE

EXAMPLE:
I(O)-320 D1A (150 - 160 HP)
I(O)-360 A1A (180 HP)

ENGINE STYLE

(PLEASE CIRCLE ONE FOR EACH CATEGORY)

INDUCTION: VERTICAL OR HORIZONTAL

CYLINDER TYPE: PARALLEL VALVE OR ANGLE VALVE

DISPLACEMENT: 235 OR 290 OR 320 OR 360 OR 540

MOUNT STYLE: DYNAFOCAL I OR DYNAFOCAL II OR CONICAL

FUEL METERING: FUEL INJECTED OR CARBURETTED

ENGINE SUPPLIER: AERO SPORT POWER OR SUPERIOR OR
MATTITUCK OR LYCOMING

OTHER _____

CUSTOMER NAME: _____

CUSTOMER NUMBER: _____