

TOTAL PERFORMANCE
VAN'S AIRCRAFT

14401 Keil Road NE, Aurora, Oregon, USA 97002
PHONE 503-678-6545 • FAX 503-678-6560 • www.vansaircraft.com • info@vansaircraft.com
Service Letters and Bulletins: www.vansaircraft.com/public/service.htm

REVISION DESCRIPTION:

Page: 51A-02 REV 4: Revise SLSA depiction of Passenger Warning placard as follows:

“THIS AIRCRAFT WAS MANUFACTURED IN
ACCORDANCE WITH LIGHT-SPORT AIRCRAFT AIRWORTHINESS
STANDARDS AND DOES NOT CONFORM TO STANDARD
CATEGORY AIRWORTHINESS REQUIREMENTS
INTENTIONAL SPINS PROHIBITED”

should be

"PASSENGER WARNING
THIS AIRCRAFT WAS MANUFACTURED IN ACCORDANCE WITH
LIGHT SPORT AIRCRAFT AIRWORTHINESS STANDARDS AND DOES NOT
CONFORM TO STANDARD CATEGORY AIRWORTHINESS REQUIREMENTS
NO INTENTIONAL SPINS"

Revise ELSA depiction of Passenger Warning placard as follows:

"PASSENGER WARNING-
THIS AIRCRAFT IS AN EXPERIMENTAL LIGHT-SPORT
AIRCRAFT AND DOES NOT COMPLY WITH FEDERAL SAFETY
REGULATIONS FOR STANDARD AIRCRAFT"

should be

"PASSENGER WARNING
THIS AIRCRAFT IS AN EXPERIMENTAL AIRCRAFT AND DOES NOT COMPLY
WITH FEDERAL SAFETY REGULATIONS FOR STANDARD AIRCRAFT
NO INTENTIONAL SPINS"

Page: 51A-04 MEMO: Remove depiction of screw heads and sight holes from lower left region of Figure 1.

Page: 51A-05 REV 1: The text "NOTE: Etch, stamp or engrave the appropriate information on the PLA ELSA DATA PLATE Stainless Data Plate before installation. The following data must be etched, stamped or engraved on the stainless data plate: Manufacturer's name (*Van's Aircraft*), model number (*RV-12*), and builder's serial number."

should be:

"... Manufacturer's name and country of manufacture of the kit (*Van's Aircraft, Inc. - U.S.A.*); model number (*RV-12*); aircraft serial number which is the same as the builder's serial number; and date of manufacture, see FAA Form 8130-15, box 4 (*MM/DD/YY*)."

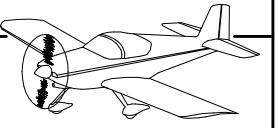

SECTION 51A PLACARDS & CERTIFICATION DOCUMENTS

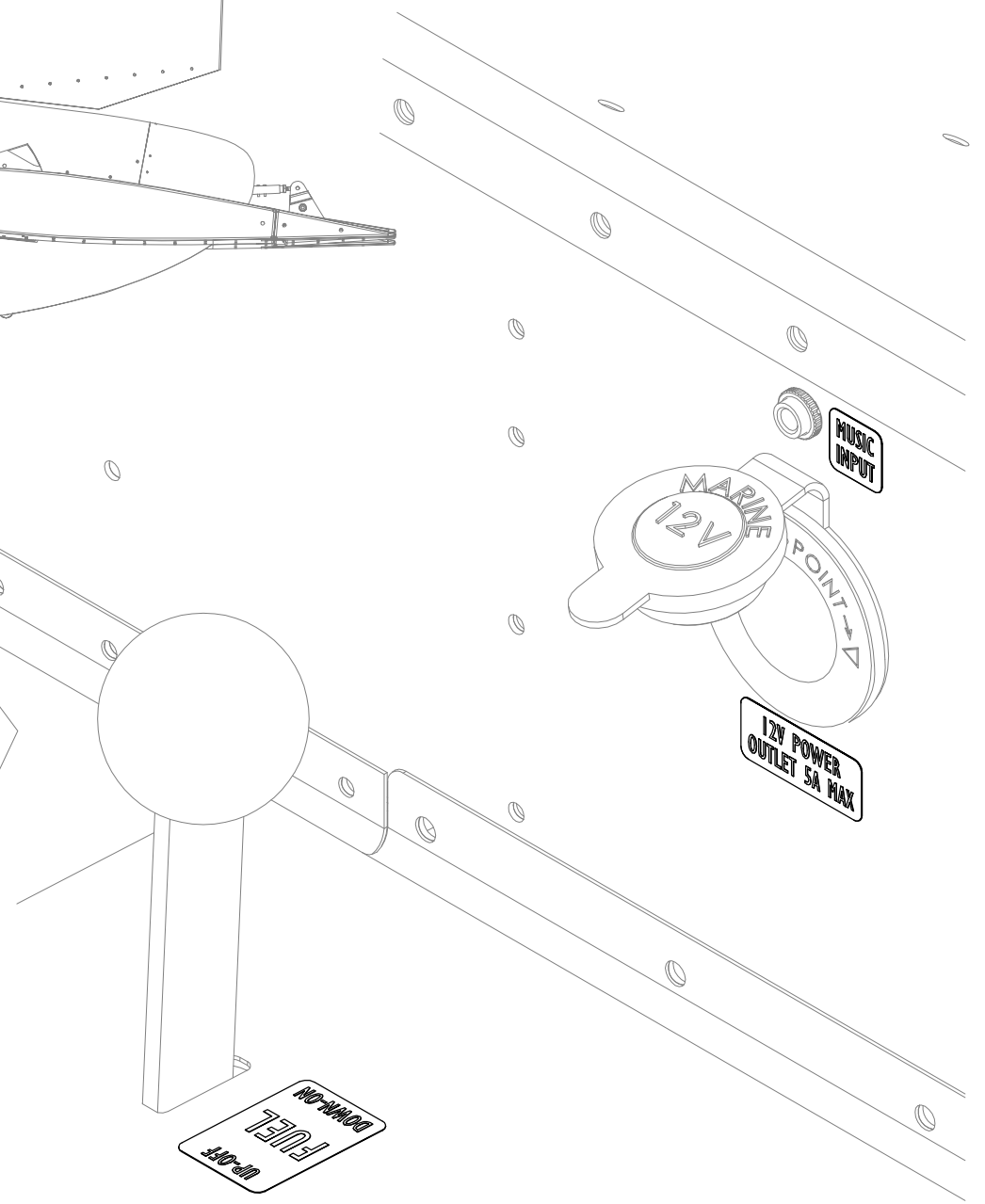
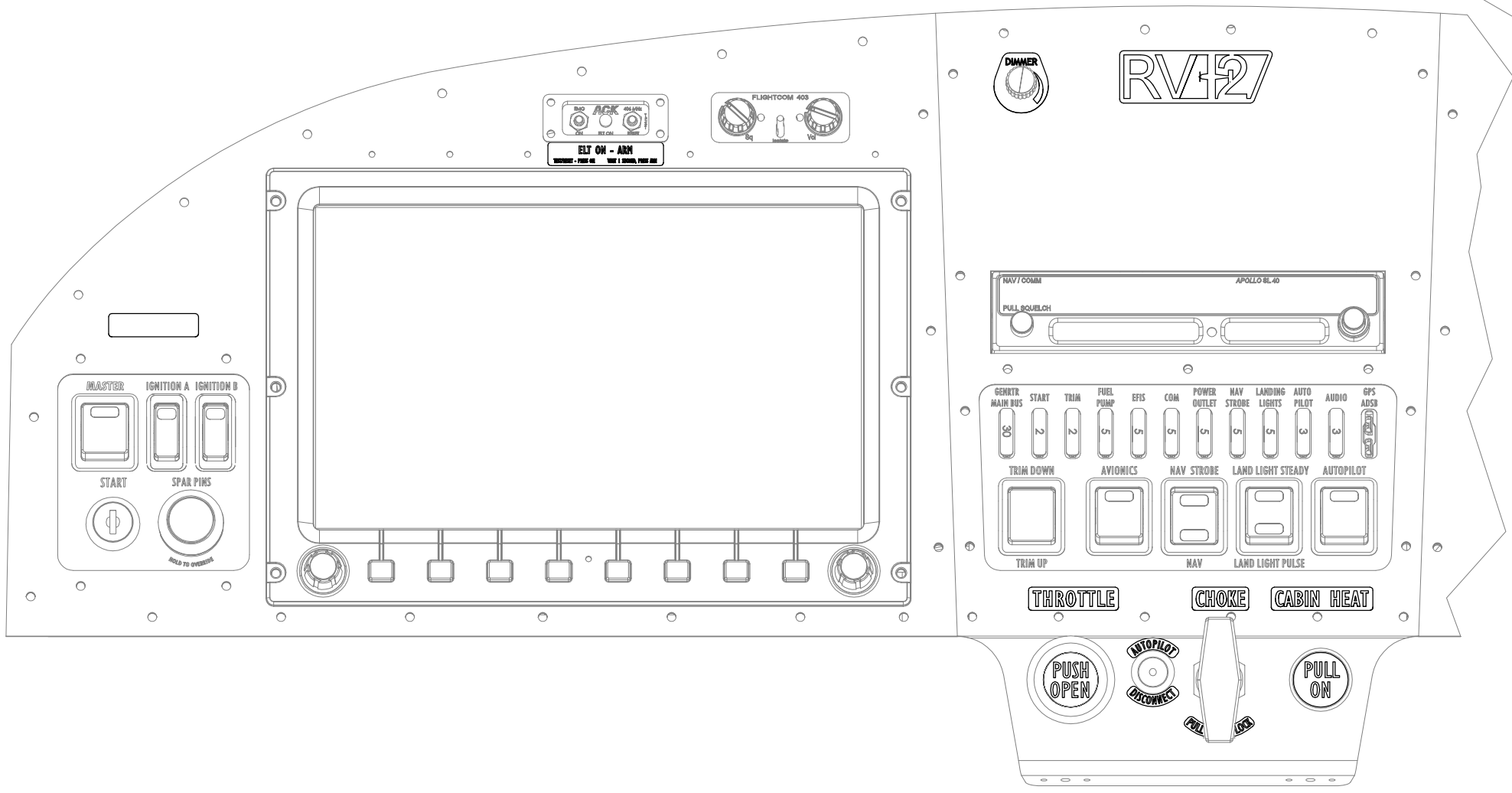
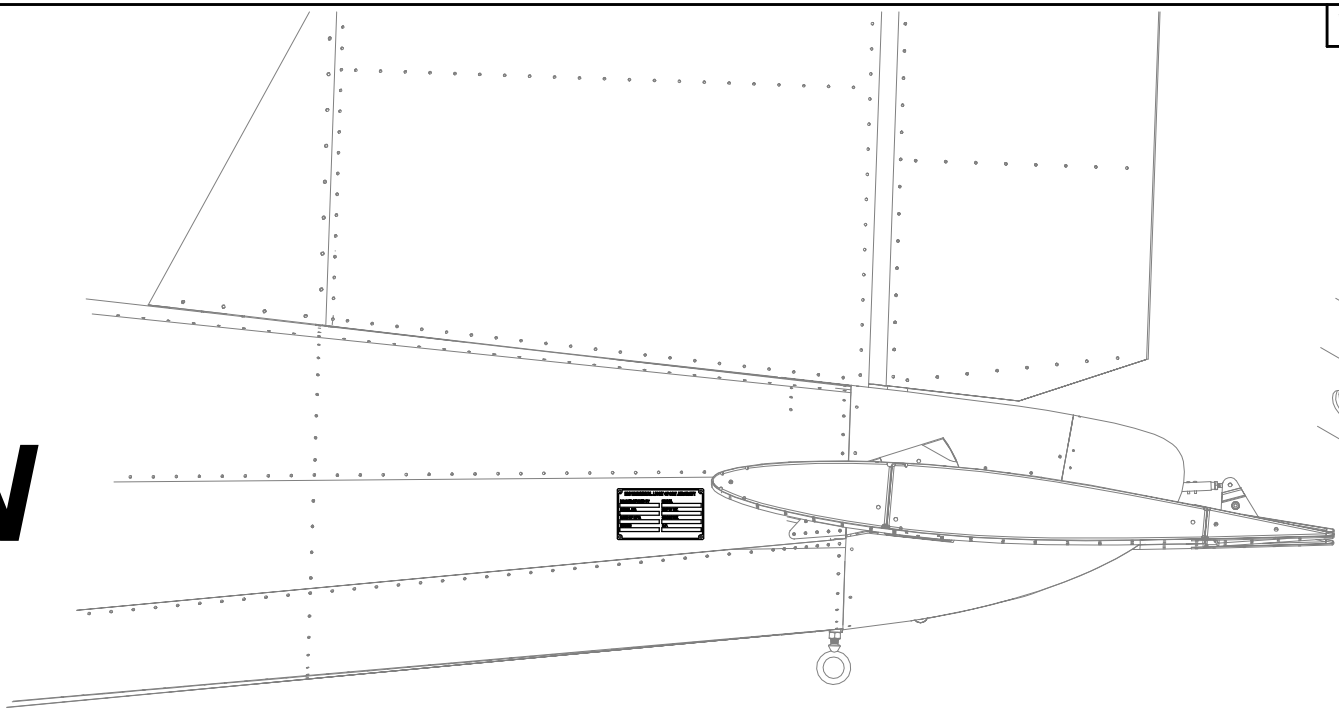



NOTE: Some labels are integrated into the parts themselves. Fuse labels, and instrument panel switch markings are integrated as shown in Figure 1. If not installing the corresponding option for the switches shown in Figure 1, the switches must be labeled as inoperable.

Interior Label Sheet labels are printed on a thin sheet of metal. Bending the interior label sheet labels may cause creasing or even break the label. To make removal of the labels from the label sheet easier, cut the label sheet with scissors then peel the paper backing off the back of the label. Take care when placing the labels that surface is clean and dry (denatured alcohol works well) and that the labels are properly aligned. Press labels firmly to adhere.

NOTE: F-1200 is for ELSA and F-1200SLSA is for SLSA. F-1200 will be referenced in the text for the remainder of this section.

Step 1: Install the F-1200 Interior Label Sheet labels on the instrument panels as shown in Figure 1. A piece of narrow masking tape placed below the cutout for the switch module makes alignment of the throttle, choke, and cabin heat labels easier. See Figure 1.

PLACARD ONLY REQUIRED FOR ARTEX ME406 ELT

AIRCRAFT IDENTIFICATION NUMBER

WARNING! FLIGHT INTO IMC IS PROHIBITED

ELT ON - ARM
TEST/RESET - PRESS ON WAIT 1 SECOND, PRESS ARM

DIMMER

RV-12

SLSA
PASSENGER WARNING
THIS AIRCRAFT WAS MANUFACTURED IN ACCORDANCE WITH LIGHT SPORT AIRCRAFT AIRWORTHINESS STANDARDS AND DOES NOT CONFORM TO STANDARD CATEGORY AIRWORTHINESS REQUIREMENTS
NO INTENTIONAL SPINS

ELSA
PASSENGER WARNING
THIS AIRCRAFT IS AN EXPERIMENTAL AIRCRAFT AND DOES NOT COMPLY WITH FEDERAL SAFETY REGULATIONS FOR STANDARD AIRCRAFT
NO INTENTIONAL SPINS

FUSE AND PANEL SWITCH MARKINGS, TYP

SWITCHES FOR OPTIONAL KITS

PASSENGER WARNING
THIS AIRCRAFT IS AN EXPERIMENTAL AIRCRAFT AND DOES NOT COMPLY WITH FEDERAL SAFETY REGULATIONS FOR STANDARD AIRCRAFT
NO INTENTIONAL SPINS

NOTE: The custom aircraft identification number or "N" number for the instrument panel may be purchased at a local sign or trophy shop or created using a label printer. The placard should be clearly legible. The font type used on the other placards is "Gill Sans MT Condensed".

WARNING!
FLIGHT INTO IMC IS PROHIBITED

LOCATION MAY VARY. PLACE ABOVE DISPLAY

NARROW TAPE

THROTTLE CHOKE CABIN HEAT

THROTTLE

CHOKE

CABIN HEAT

FIGURE 1: INSTRUMENT PANEL LABEL PLACEMENT



Step 1: Install the F-1200 Interior Label Sheet fuel valve label on the F-1214 Step Floor Cover as shown in Figure 1.

Step 2: Install the F-1200 Interior Label Sheet music input and 12V power outlet labels on the F-1203A Bulkhead as shown in Figure 1.

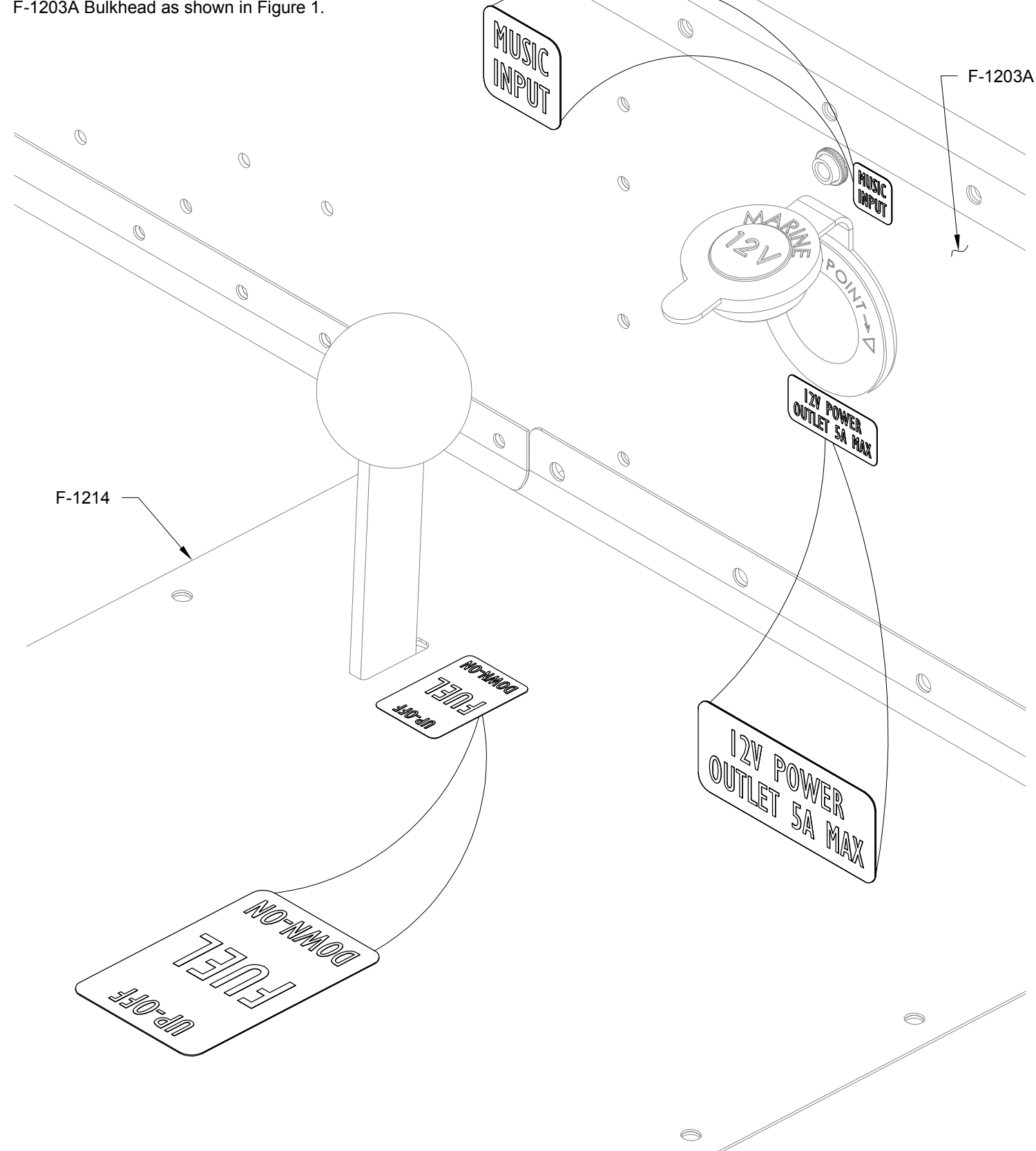

FIGURE 1: FUEL VALVE LABEL PLACEMENT

Step 3: Install the F-1200 Interior Label Sheet baggage capacity label and the PLA EXPERIMENTAL 2" decal on the F-1207 Baggage Bulkhead Corrugation as shown in Figure 2.

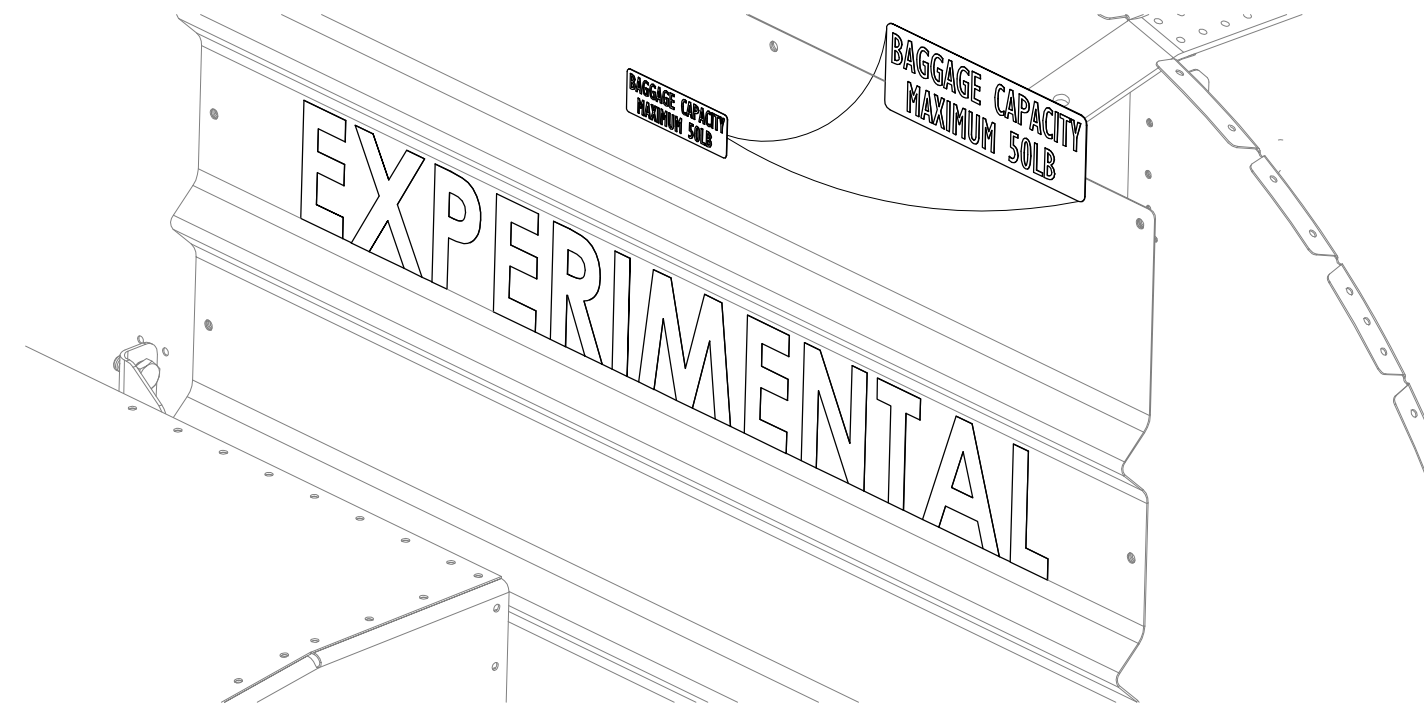
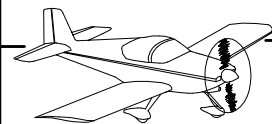

FIGURE 2: BAGGAGE BULKHEAD CORRUGATION LABELS
(ELSA "EXPERIMENTAL" SHOWN FOR SLSA USE "LIGHT-SPORT" AT THE SAME LOCATION)



NOTE: The VELCRO X 5 Double Sided Velcro Tape may be supplied on a single backing side by side. If this is the case, simply fold the Velcro halves over on each other so that the pieces will be aligned when cut and installed.

Step 1: Cut the VELCRO X 5 Double Sided Velcro Tape into two pieces and remove the backing on one side of each to adhere to the vinyl envelope provided in the kit. Remove the paper backing from the other side of the double sided velcro tape and position the VA-221 4 X 6 Vinyl Envelope W/Flap on the F-1207C Baggage Bulkhead. Press firmly. The 4 X 6 vinyl envelope w/flap will hold the Airworthiness Certificate as required in the RV-12 Production Acceptance Procedures Section G10. See Figure 1.

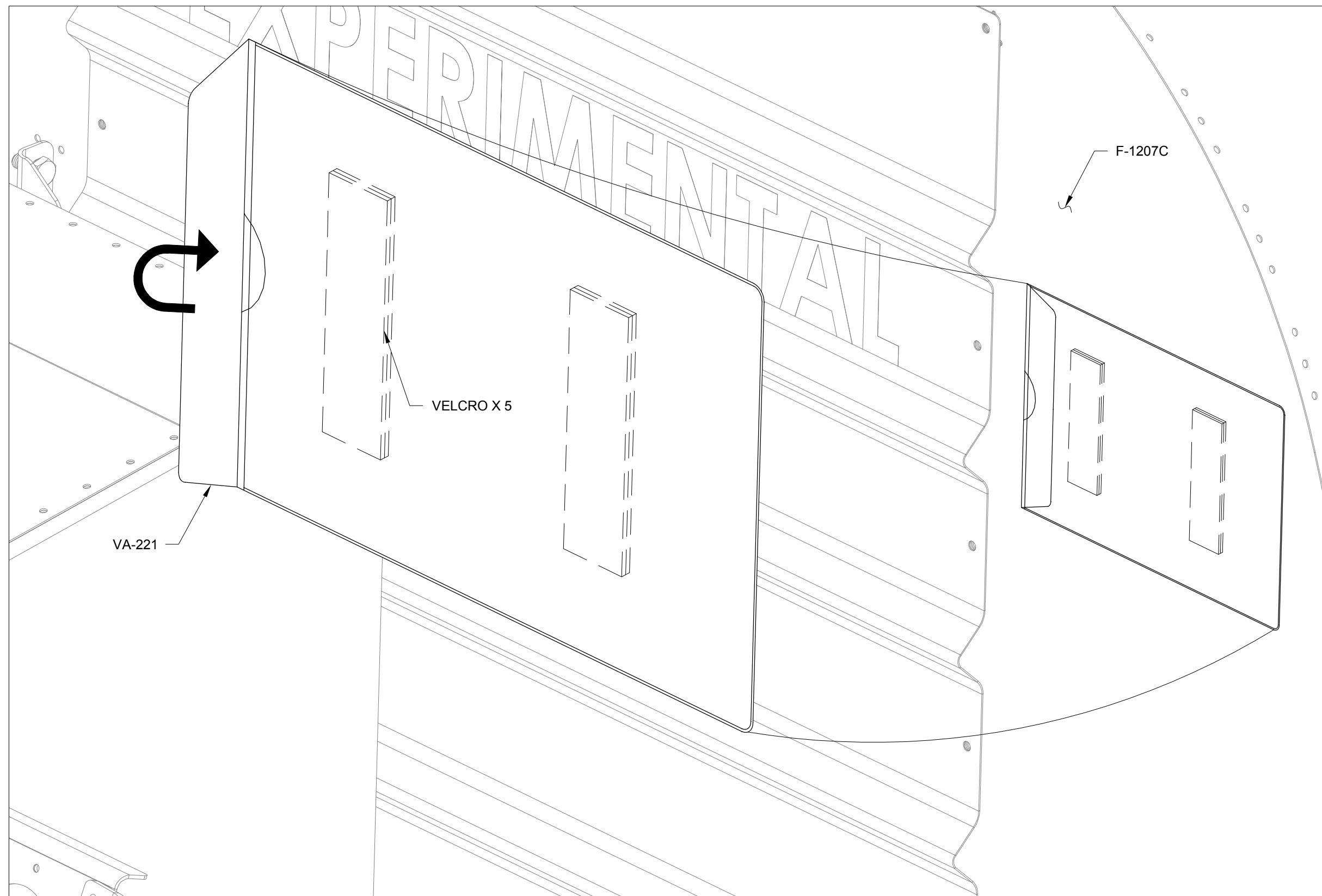
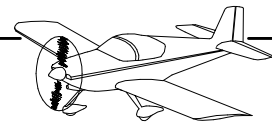

FIGURE 1: VINYL ENVELOPE PLACEMENT



NOTE: Etch, stamp or engrave the appropriate information on the PLA ELSA DATA PLATE Stainless Data Plate before installation. The following data must be etched, stamped or engraved on the stainless data plate: Manufacturer's name and country of manufacture of the kit (*Van's Aircraft, Inc. - U.S.A.*); model number (*RV-12*); aircraft serial number which is the same as the builder's serial number; and date of manufacture, see FAA Form 8130-15, box 4 (*MM/DD/YY*).

The vinyl placards installed in this section are supplied with a slick backing on the adhesive side, and a second layer on the top to maintain vinyl label position during installation. To install, remove the slick backing paper and position label carefully. Rub the label firmly to adhere to the surface and then peel away the top paper layer by pulling the paper back over itself. Pulling directly up and away from the label may pull the label away from the mounting surface.

Step 1: Align the PLA ELSA DATA PLATE Stainless Data Plate on the F-1280-L Left Side Skin as shown in Figure 1 and match-drill #30 the four attachment holes.

Step 2: Install the PLA ELSA DATA PLATE Stainless Data Plate on the F-1280-L Left Side Skin with the hardware called out in Figure 1.

Step 3: Install the PLA NO PUSH BLACK or WHITE No Push Placard on the AST Assembly-L and -R as shown in Figure 1.

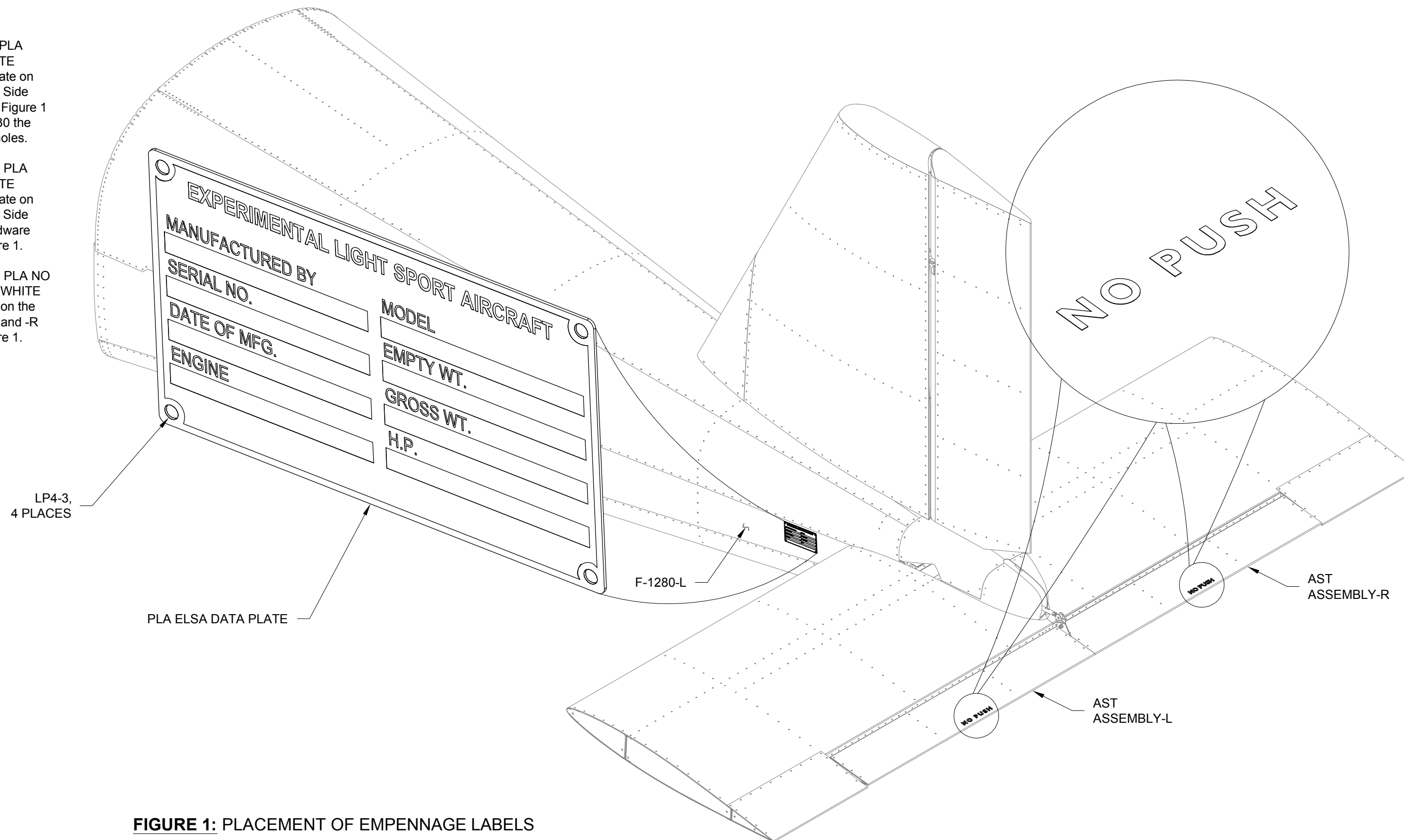
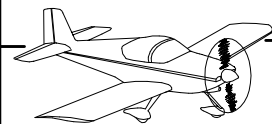

FIGURE 1: PLACEMENT OF EMPENNAGE LABELS



Step 1: Install F-1200B BLACK or WHITE Fuel Placard on the F-1277-R FWD Turtle Deck Skin. See Figure 1.

Step 2: Install the PLA OPEN (RIGHT) on the F-1277A Aft Window. See Figure 1.

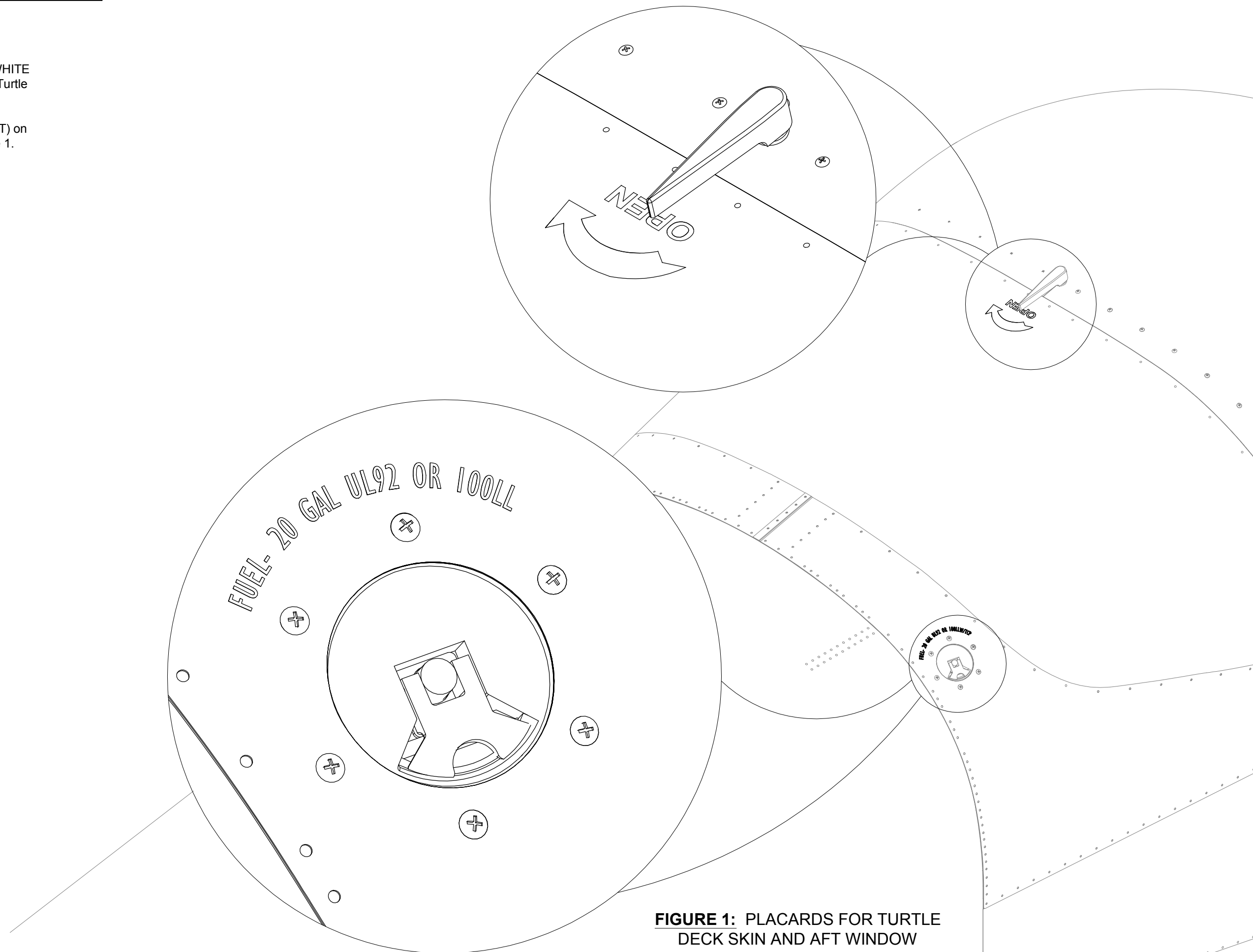

FIGURE 1: PLACARDS FOR TURTLE DECK SKIN AND AFT WINDOW