

Step 1: Dimple the three holes in each F-1201E-L and -R Oil Tank Side Brace that will receive flush fasteners as called out in Figure 1. Machine countersink the corresponding holes in the F-1201Q-L and -R Battery Mount Angles.

Step 2: Rivet the F-1201E-L and -R Oil Tank Side Braces to the F-1201A Firewall Upper. Rivet the F-1201F Battery Mount Brace to the firewall upper. See Figure 1.

Step 3: Rivet the F-1201F battery mount brace, F-1201Q-L & -R Battery Mount Angles and F-1201G Oil Tank Brace to the oil tank side braces. See Figure 1.

Step 4: Cover the head of each rivet on the firewall with a thin layer of fuel tank sealant.

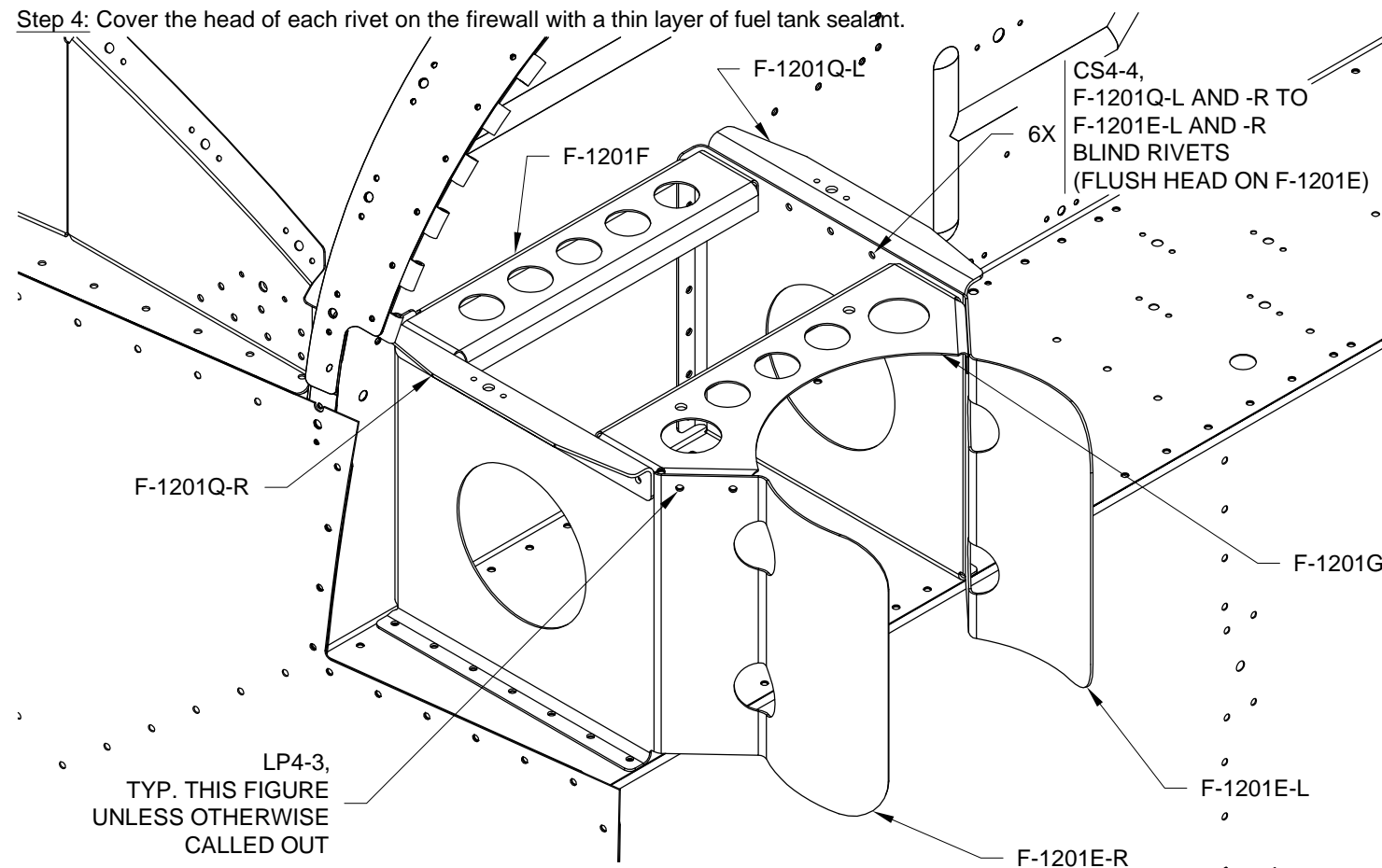

FIGURE 1: ADDING THE OIL TANK BRACES

Step 5: Make the F-1240C Clip from provided AS3-025 as shown in Figure 2. Match-Drill #40 to the F-1240B Cover Plate. Test fit the clip to the fuselage to determine which side goes up then deburr and dimple the rivet and screw holes in the clip and the cover plate then rivet the clip to the cover plate using the rivets called out in Figure 2.

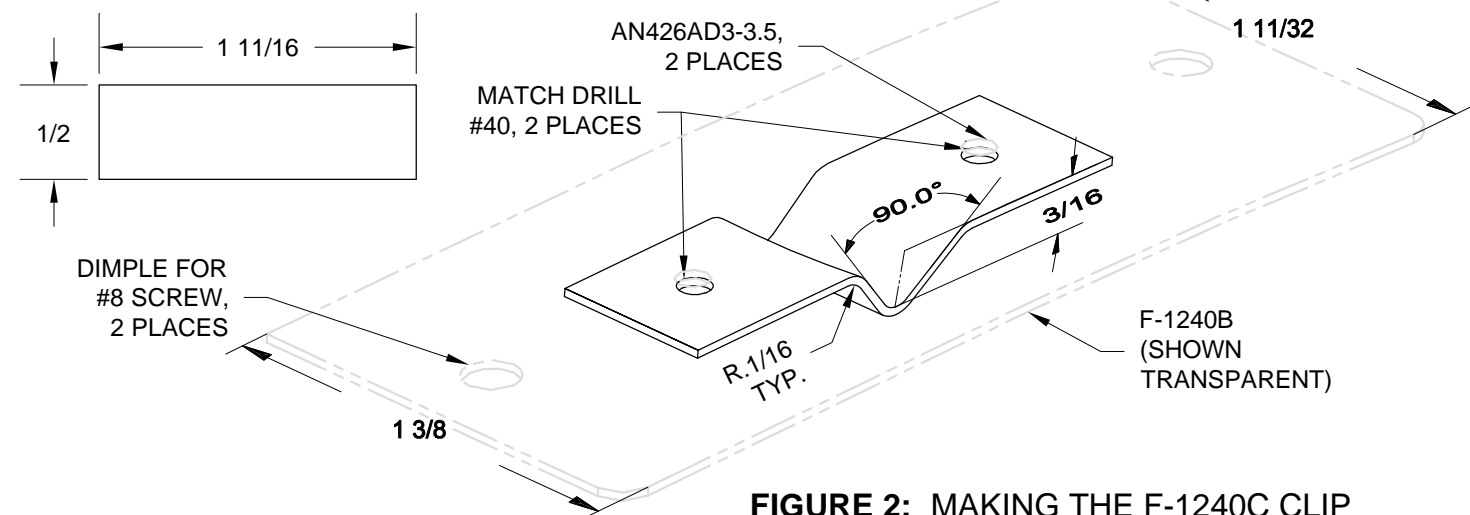

FIGURE 2: MAKING THE F-1240C CLIP

Step 6: Carefully curve the forward edge of the F-1240 Upper Forward Fuselage Skin down by hand. The upper forward fuselage skin can be laid flat on a table and the forward edge of the skin carefully worked over the edge, taking care not to crease the skin. The upper forward fuselage skin should be curved enough that the forward edge presses against the F-1201H Upper Forward Fuselage Doubler when installed. See Figure 3.

Step 7: Final-Drill #19 then dimple the holes in the F-1240 Upper Forward Fuselage Skin as shown in Figure 3.

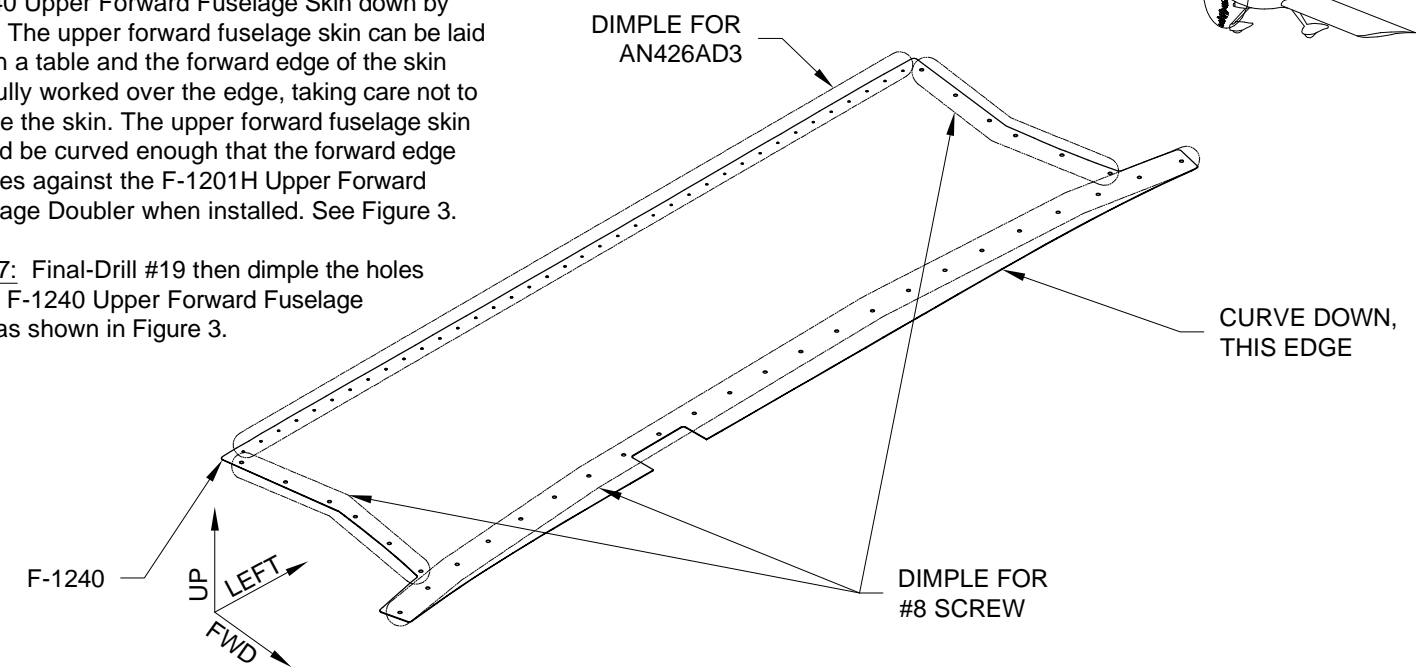

FIGURE 3: ROLLING THE UPPER FORWARD FUSELAGE SKIN

Step 8: Screw the F-1240 Upper Forward Fuselage Skin to the F-1201A Assembly, F-1270-L and F-1270-R Fuselage Side Skins and F-1202H-L and F-1202H-R Canopy Ribs. Screw the F-1240B Assembly to the upper forward fuselage skin. See Figure 4.

Step 9: Dimple the nutplates called out in Figure 4 and the rivet locations in the F-1202D-L and F-1202D-R Panel Attach Strips. Rivet the nutplates to the panel attach strips. See Figure 4.

Step 10: Start from the inboard and work out clecoing then riveting the F-1202D-L and F-1202D-R Panel Attach Strips to the F-1240 Upper Forward Fuselage Skin as shown in Figure 4.

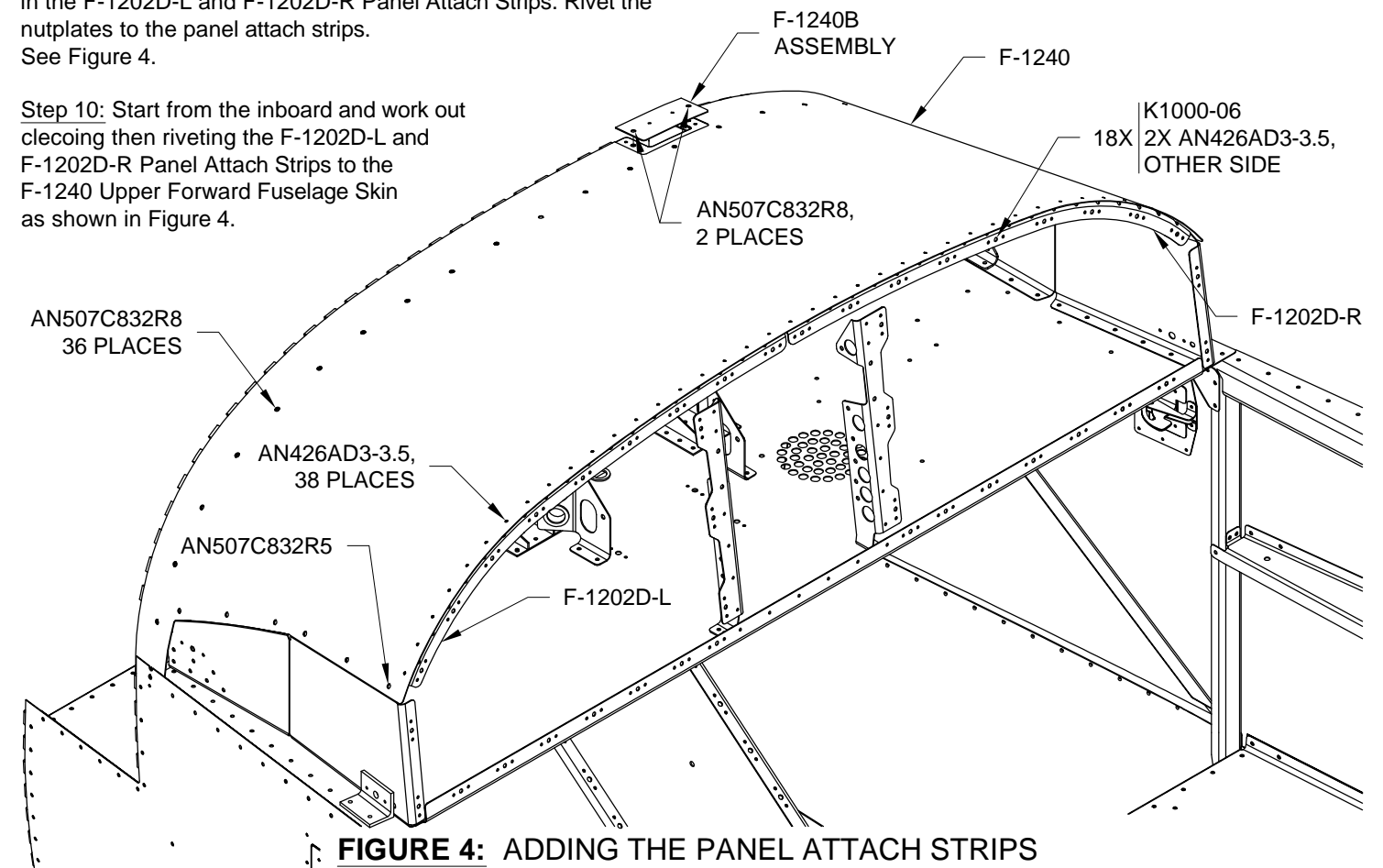

FIGURE 4: ADDING THE PANEL ATTACH STRIPS