

Step 1: Study Figure 1 to determine the forward edge, top and bottom of the F-1231B & C Roll Bar Straps.
Run the roll bar straps back and forth over the edge of a table to add a curvature to the parts. Be careful not to let the parts kink across the rivet holes. The curve does not have to be the final installed shape but enough to allow easy assembly of the roll bar. Deburr the edges of all parts used to create the Roll Bar Assembly. Cleco all of the parts of the Roll Bar Assembly together as shown in Figure 1.

Step 2: Final-Drill #30 all #40 holes in the flanges of the F-1231A-FL, -FR, -AL & -AR Roll Bar Frames and F-1231B & C Roll Bar Straps.

Step 3: Disassemble the roll bar parts, then machine countersink the **outer flanges** of the F-1231A-FL, -FR, -AL and -AR Roll Bar Frames for the head of the rivets that will eventually lay underneath the canopy except holes common to the F-1231D Roll Bar Bases. Machine countersink the two holes on the inside lower center face of the roll bar that will get flush blind rivets. See Figure 1.

CAUTION: Do not rivet the locations marked with a triangle in Figure 1 until later in the assembly process!

Step 4: Rivet the F-1231F Latch Plate to the F-1231A-AR Roll Bar Frame and aft F-1231E Splice Plate as shown in Figure 1.

Step 5: Rivet the F-1231A-FL, -FR, -AL & -AR Roll Bar Frames to the F-1231B & C Roll Bar Straps and F-1231E Splice Plates per the callouts in Figure 1 to create the Roll Bar Assembly.

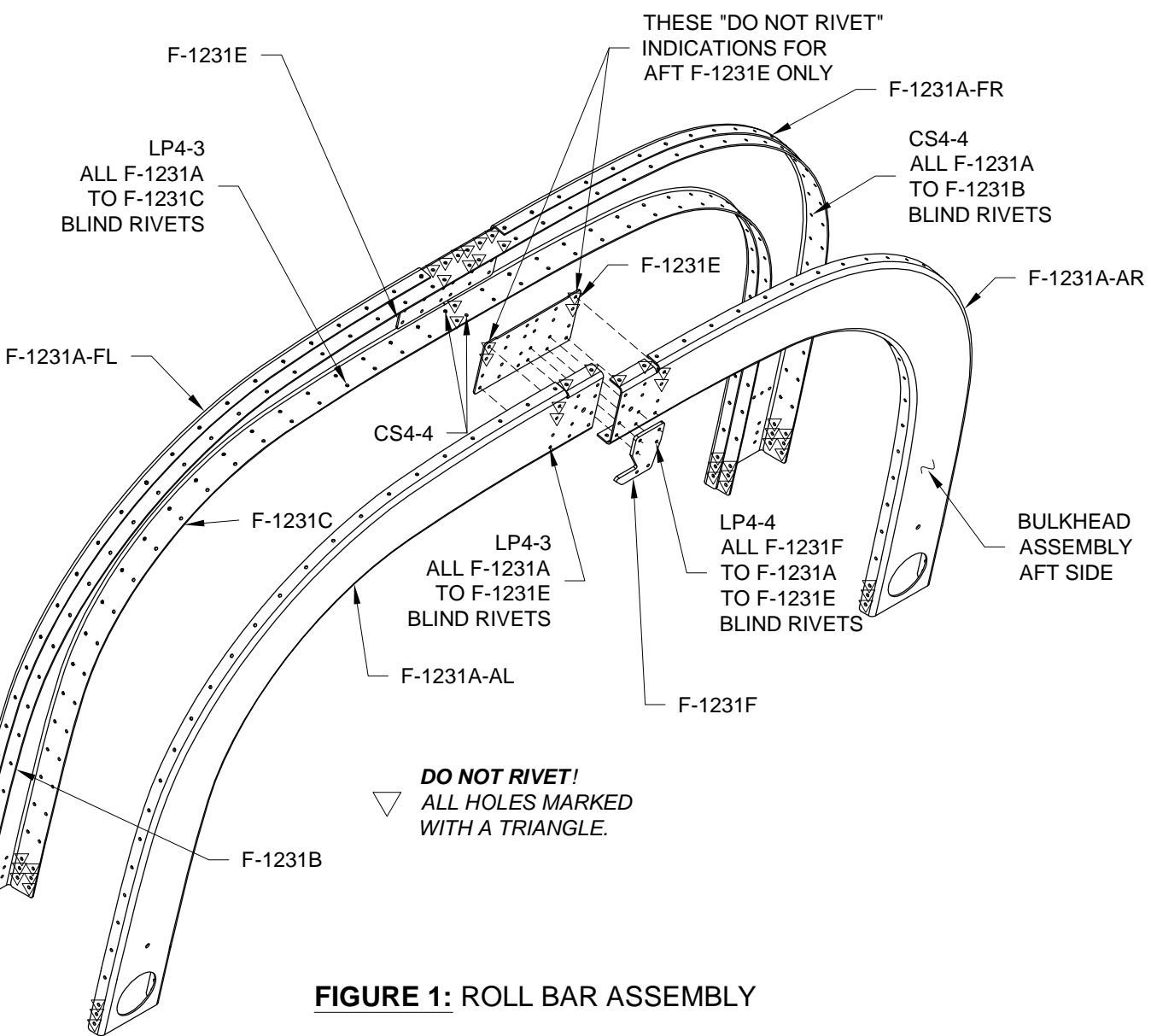

FIGURE 1: ROLL BAR ASSEMBLY

Step 6: Remove the hatched areas shown in Figure 2 from the flanges of both the F-1254-L & -R Support Frames.

Step 7: Deburr then dimple both holes indicated in Figure 2 for the head of a #8 screw.

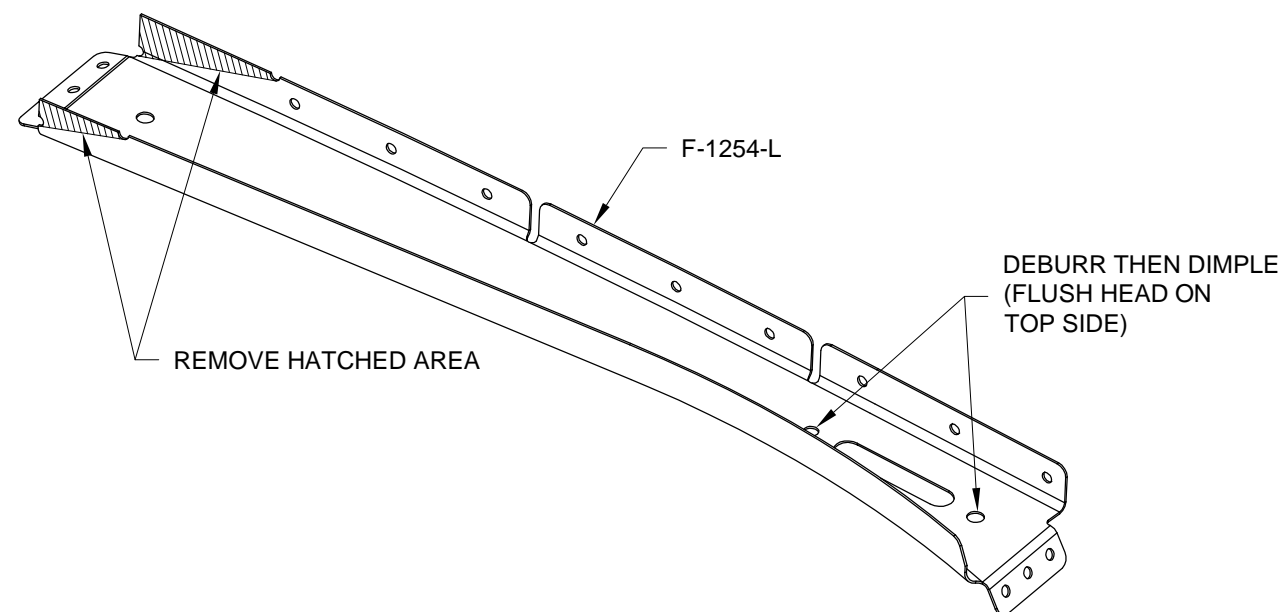

FIGURE 2: TRIMMING THE SUPPORT FRAMES

Step 8: Remove the hatched areas shown in Figure 3 to separate the F-1232B Roll Bar Brace Bracket into left and right parts.

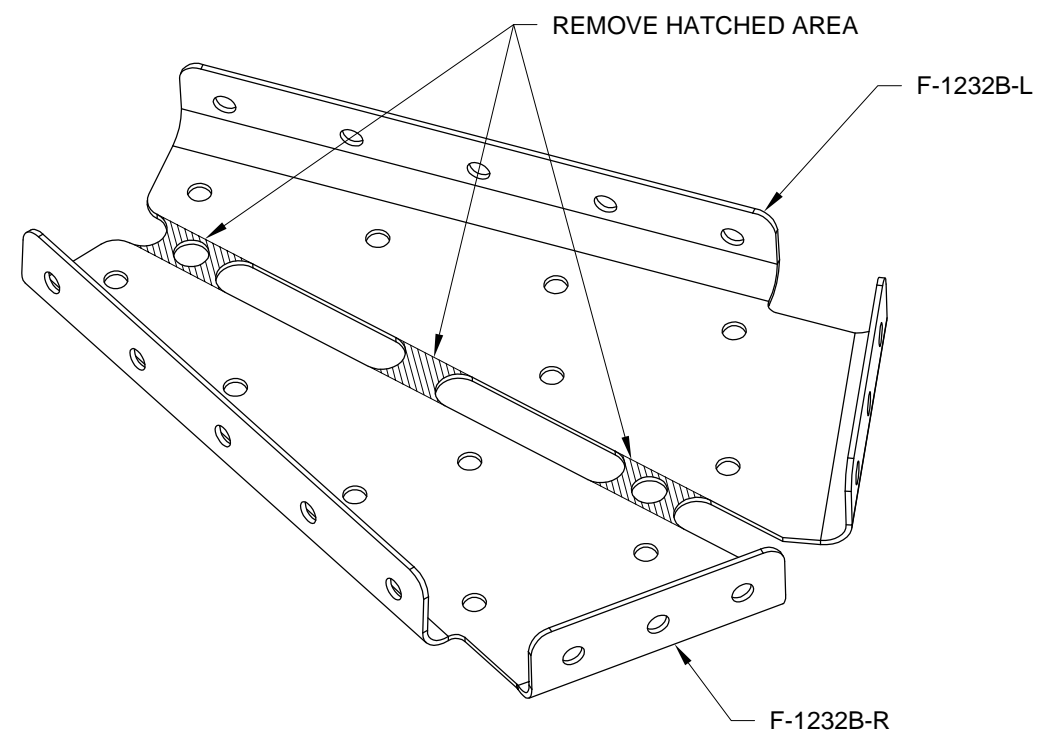

FIGURE 3: BREAKING APART THE ROLL BAR BRACE BRACKETS