

Step 1: Machine countersink the top face of the F-1205B Roll Bar Attach Plates for the nutplate attach rivets and the five locations called out in Figure 1 to create mirrored left and right parts.

Step 2: Rivet nutplates to the F-1205B-L and -R Roll Bar Attach Plates as shown in Figure 1 (Temporarily thread a bolt into the nutplate while riveting).

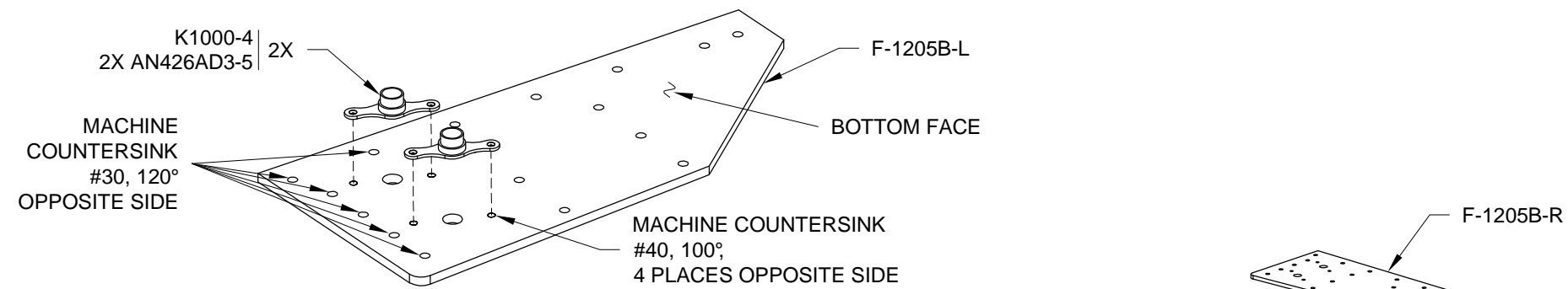

**FIGURE 1: LEFT ROLL BAR ATTACH PLATE**

Step 3: Rivet the F-1205A Mid Fuse Brace to the aft side of the F-1204B-L and -R Aft Bulkhead Sides. See Figure 2.

Step 4: Rivet the F-1205B-L and -R Roll Bar Attach Plates and F-1205C Mid Fuse Brace Close-out to the F-1205A Mid Fuse Brace and F-1204C-L and -R Fwd Bulkhead Sides (do not rivet the roll bar attach plate to the F-1204F-L and -R Aft Side Bulkheads). See Figure 2.

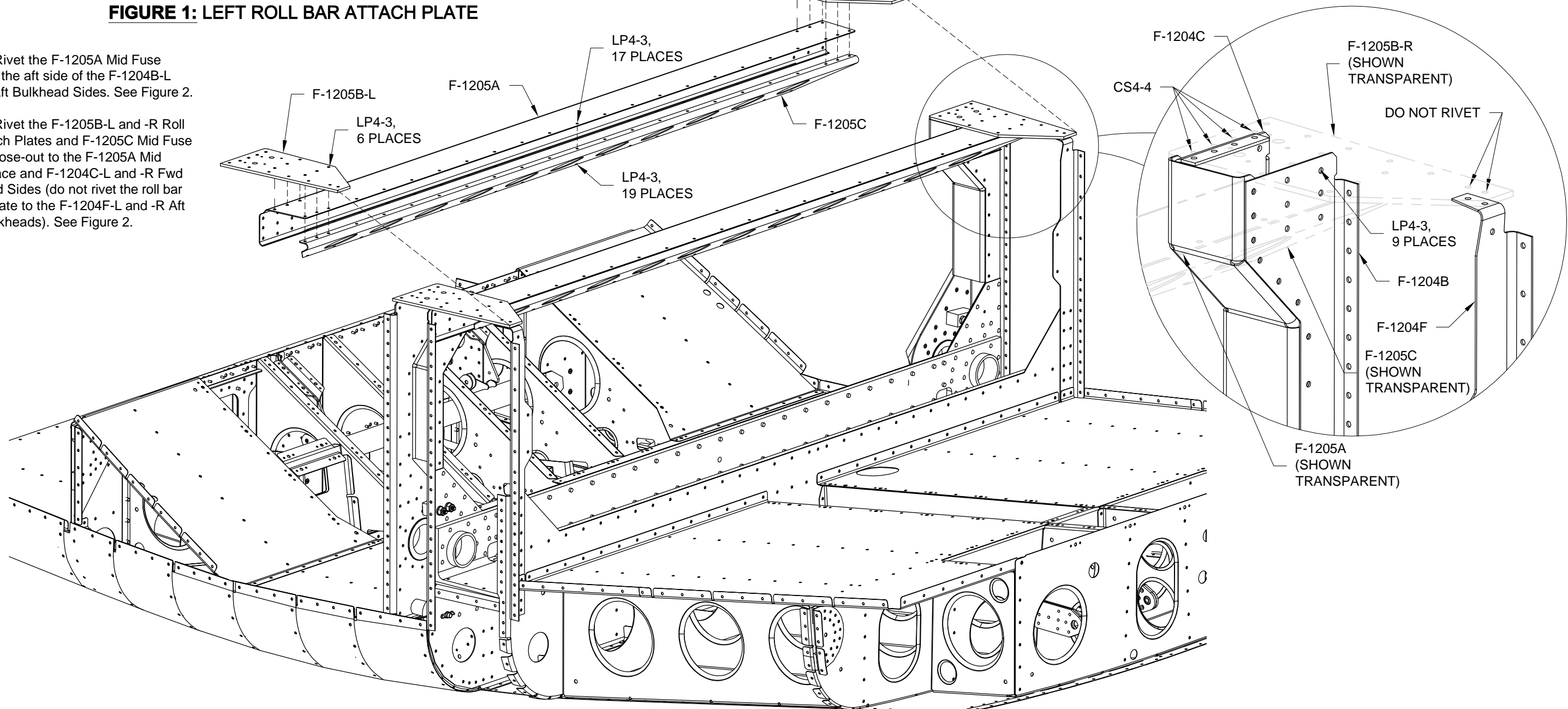

**FIGURE 2: INSTALLING THE MID FUSE BRACE**