

**NOTE:** The fuel flow meter provided will be one of two types. Page 28-05, Figure 1 includes a depiction of both types. Determine the fuel flow meter provided with the kit and use the applicable hardware.

Step 1: Install nutplates to the VA-188 FLO-SCAN Mount Bracket per the call-outs in Figure 1 if using a Flo-Scan Fuel Flow Meter or Figure 2 if using a FT-60 Fuel Flow Meter.

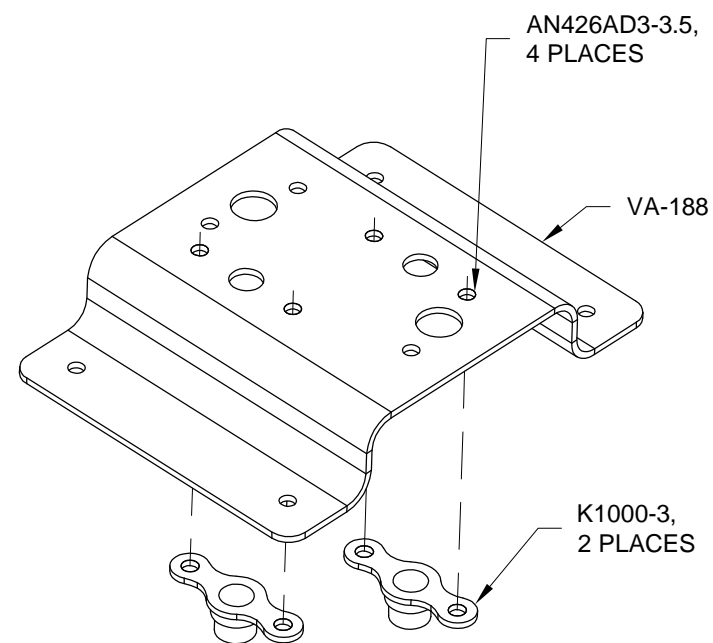

**FIGURE 1: INSTALLING NUTPLATES FOR FLO-SCAN**

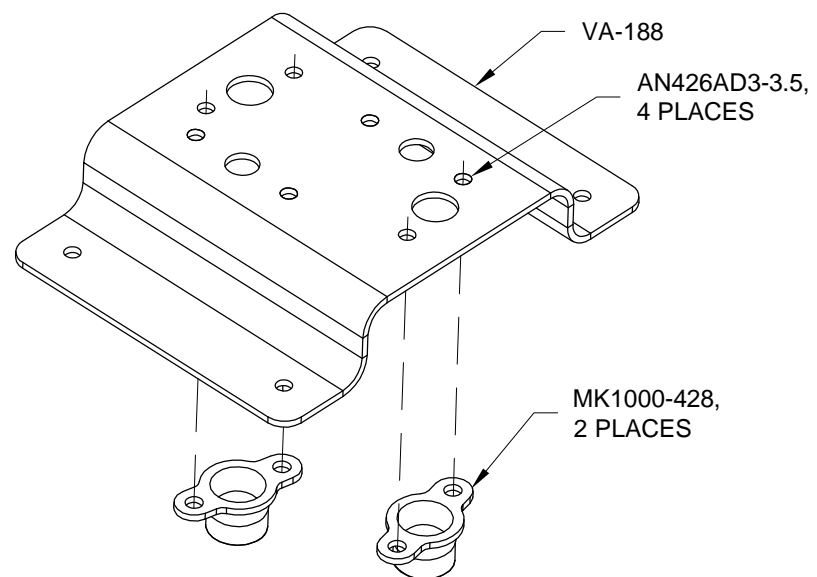

**FIGURE 2: INSTALLING NUTPLATES FOR FT-60**

Step 2: Cleco the VA-188 FLO-SCAN Mount Bracket to the F-1272 Fwd Fuse Floor Skin. Final-Drill #30 the four attach holes. Remove the bracket and deburr both parts.

Step 3: Rivet the VA-188 FLO-SCAN Mount Bracket to the F-1272 Fwd Fuse Floor Skin per the call-outs in Figure 2.

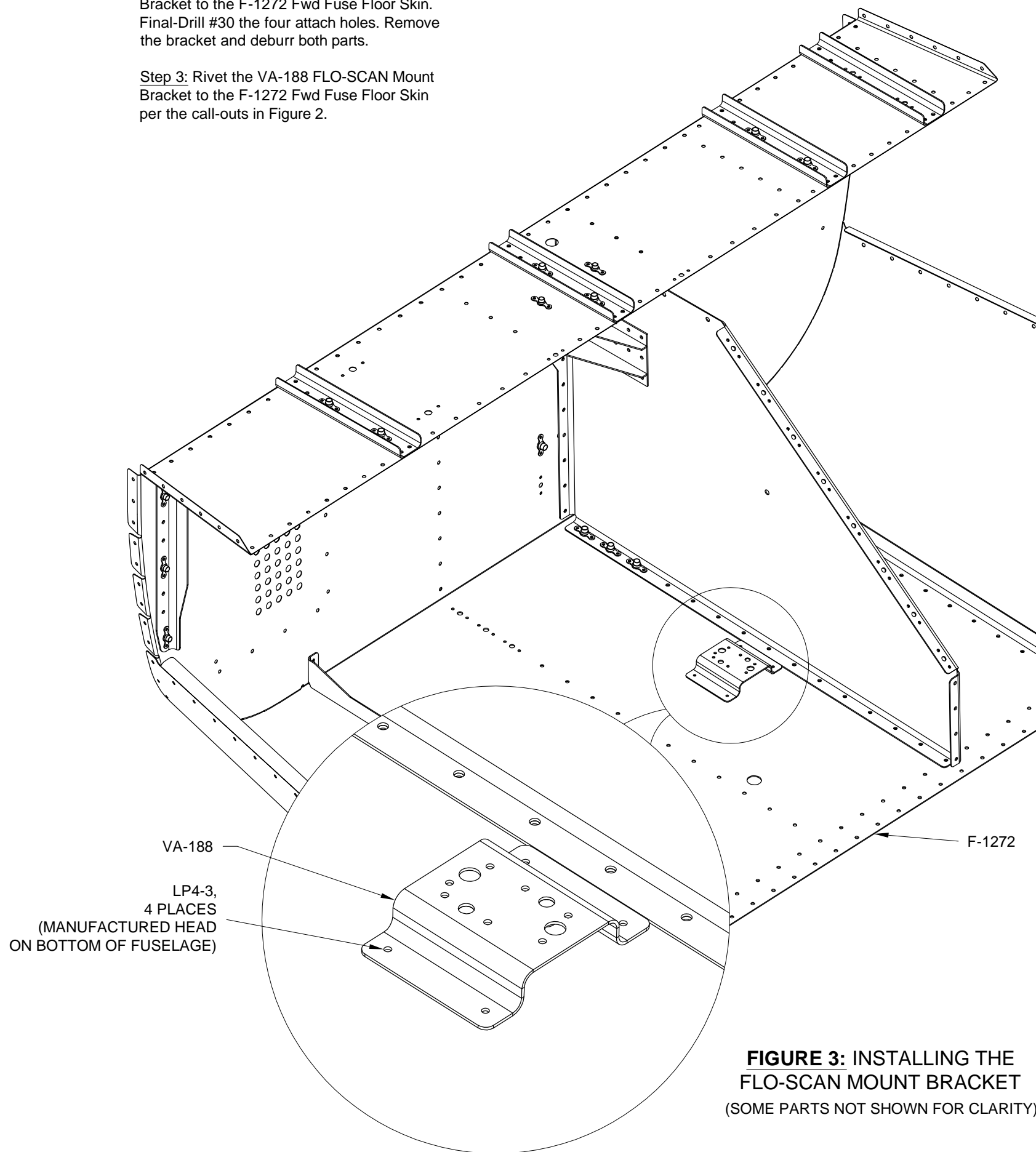

**FIGURE 3: INSTALLING THE FLO-SCAN MOUNT BRACKET (SOME PARTS NOT SHOWN FOR CLARITY)**