



Step 1: Cut apart and deburr the F-1257 Rudder Pedal Support Channels as shown in Figure 1.

Step 2: Dimple the aft two holes and nutplate attach holes in the F-1257 Rudder Support Channels. Dimple the corresponding holes in the F-1201B Firewall Shelf. See Figure 2.

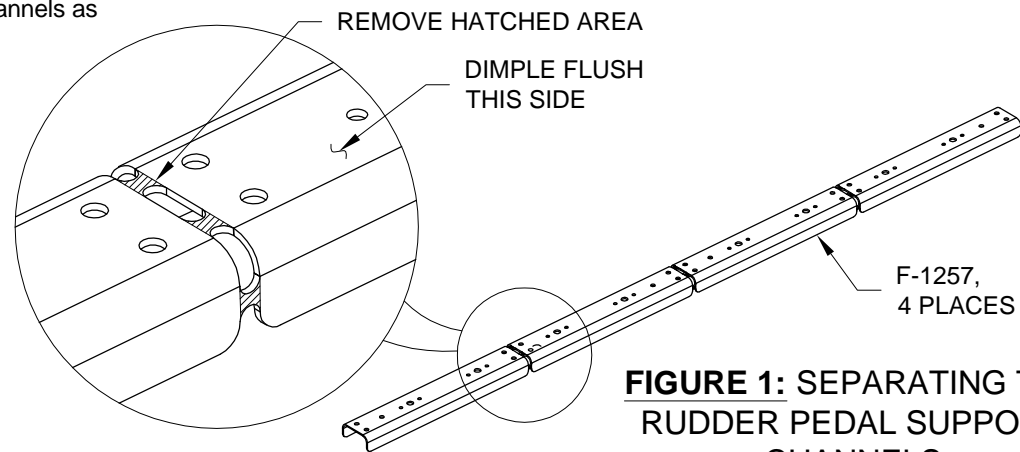

FIGURE 1: SEPARATING THE RUDDER PEDAL SUPPORT CHANNELS

Step 3: Dimple then rivet nutplates to the F-1201B Firewall Shelf and F-1257 Rudder Pedal Support Channels as shown in Figure 2.

Step 4: Smear a thin layer of fuel tank sealant on the top surface of the top flange of the F-1201C Firewall Bottom. Cleco then rivet the F-1201B Firewall Shelf and F-1257 Rudder Pedal Support Channels to the Fwd Lwr Fuse Assembly per the call outs in Figure 2.

Step 5: Fill the tooling holes on the F-1201C Firewall Bottom with blind rivets. See Figure 2.

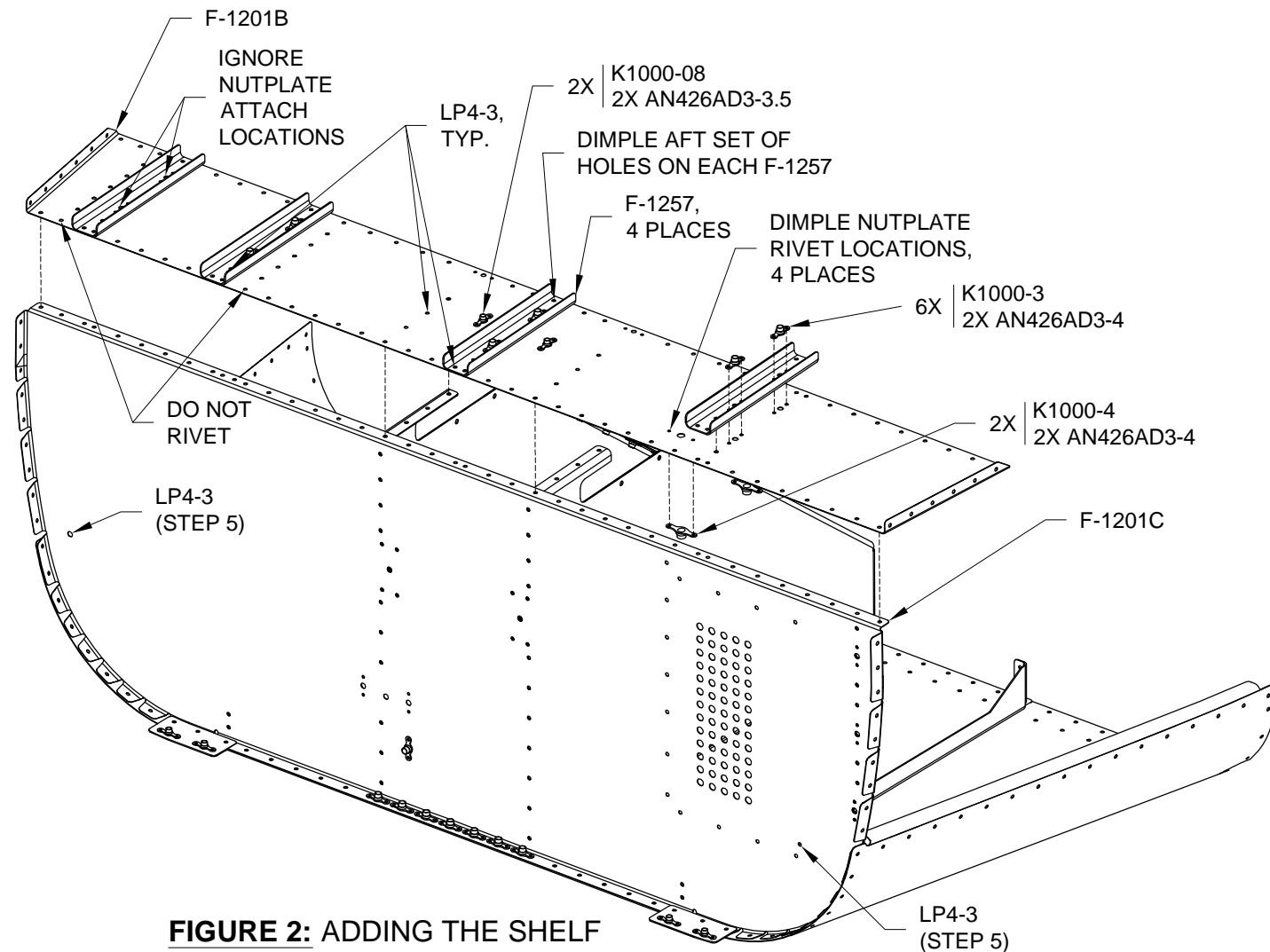

FIGURE 2: ADDING THE SHELF

Step 6: Make the F-1201L Bracket from AA6-063X3/4X3/4 per the dimensions given in Figure 3.

Step 7: Draw a centerline on the forward face of the F-1201L Bracket. See Figure 3.

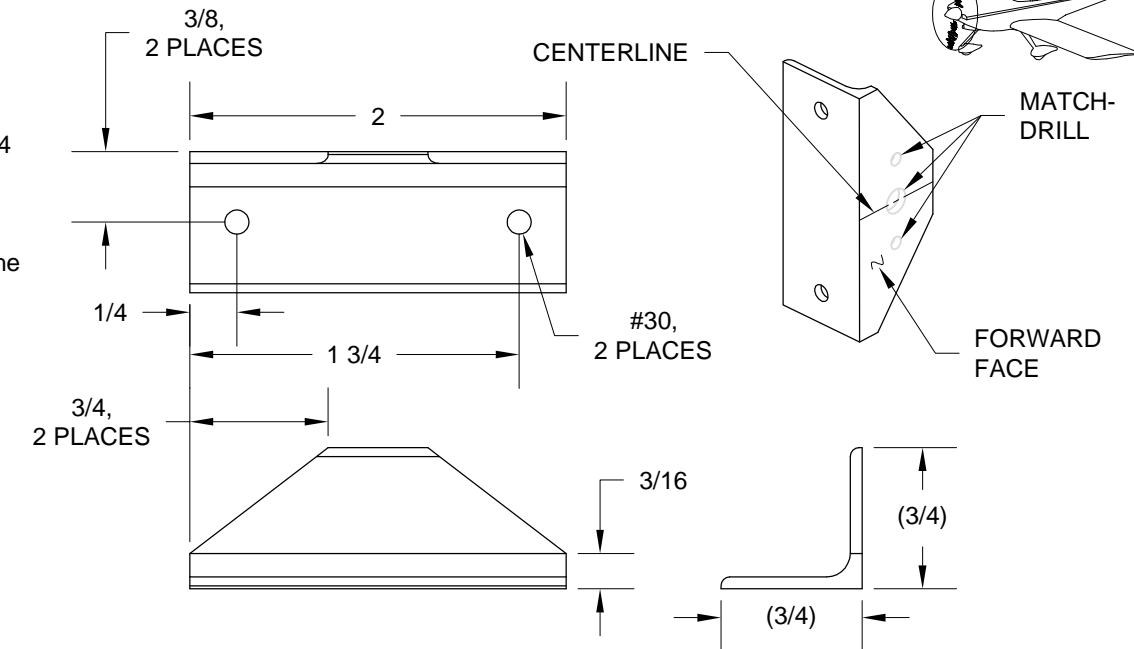

FIGURE 3: MAKING F-1201L

Step 8: Place the F-1201L Bracket flush against the F-1217A-R Tunnel Rib and F-1201C Firewall Bottom dimples as shown in Figure 4. Align the centerline on the forward face of the bracket with the gascolator attach hole (Page 22-2, Figure 3) then match-drill #40 the nutplate attach holes in the firewall bottom into the bracket (use a small wood block to protect your fingers). Remove the bracket and machine countersink the nutplate attach holes in the forward face of the bracket for the dimples in the firewall bottom.

Step 9: Cleco the F-1201L Bracket to the F-1201C Firewall Bottom. Match-Drill #30 and cleco the two holes in the inboard flange of the bracket into the F-1217A-R Tunnel Rib (a #30 12 inch extension bit is useful for these holes). Match-Drill #12 the gascolator attach hole in the firewall bottom into the bracket. See Figure 4.

Step 10: Deburr the F-1217A-R Tunnel Rib and F-1201L Bracket. Prime the bracket.

Step 11: Rivet the F-1201L Bracket to the F-1217A-R Tunnel Rib and with a nutplate to the F-1201C Firewall Bottom as shown in Figure 4. Dimple then rivet a second nutplate to the remaining gascolator attach hole on the firewall bottom inside the tunnel.

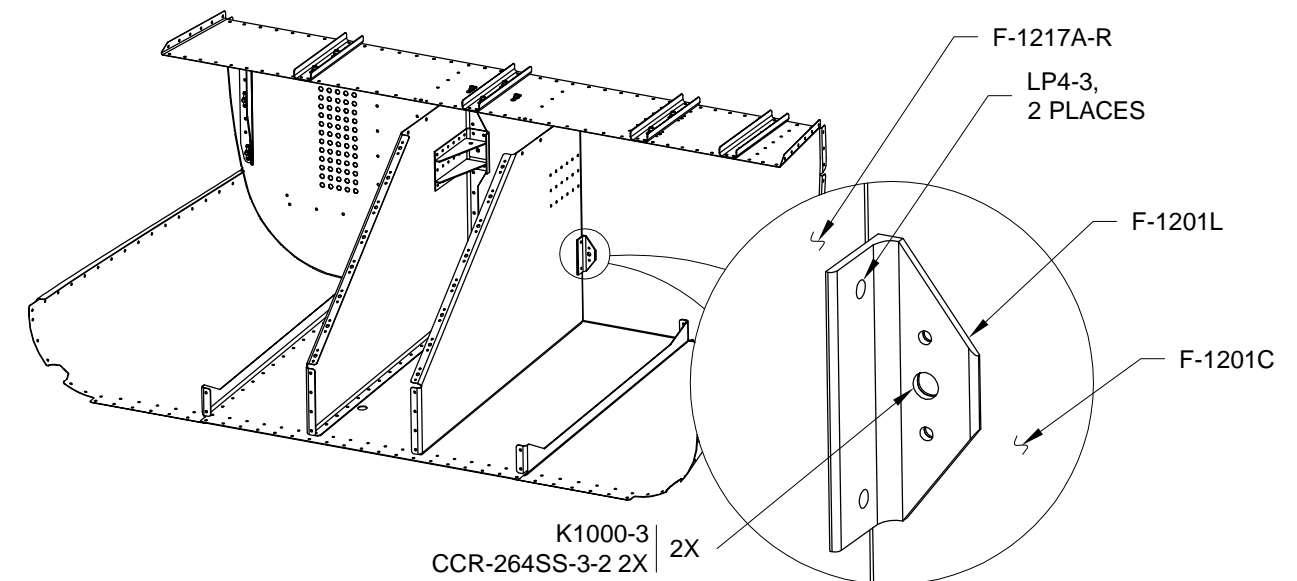

FIGURE 4: INSTALLING F-1201L