

Step 1: Make the A-1207-L Actuation Bracket from AA6-125 x 1 1/2 x 2 x 10 as shown in Figure 1.

Make the A-1207-R Actuation Bracket which is the opposite of the A-1207-L Actuation Bracket.

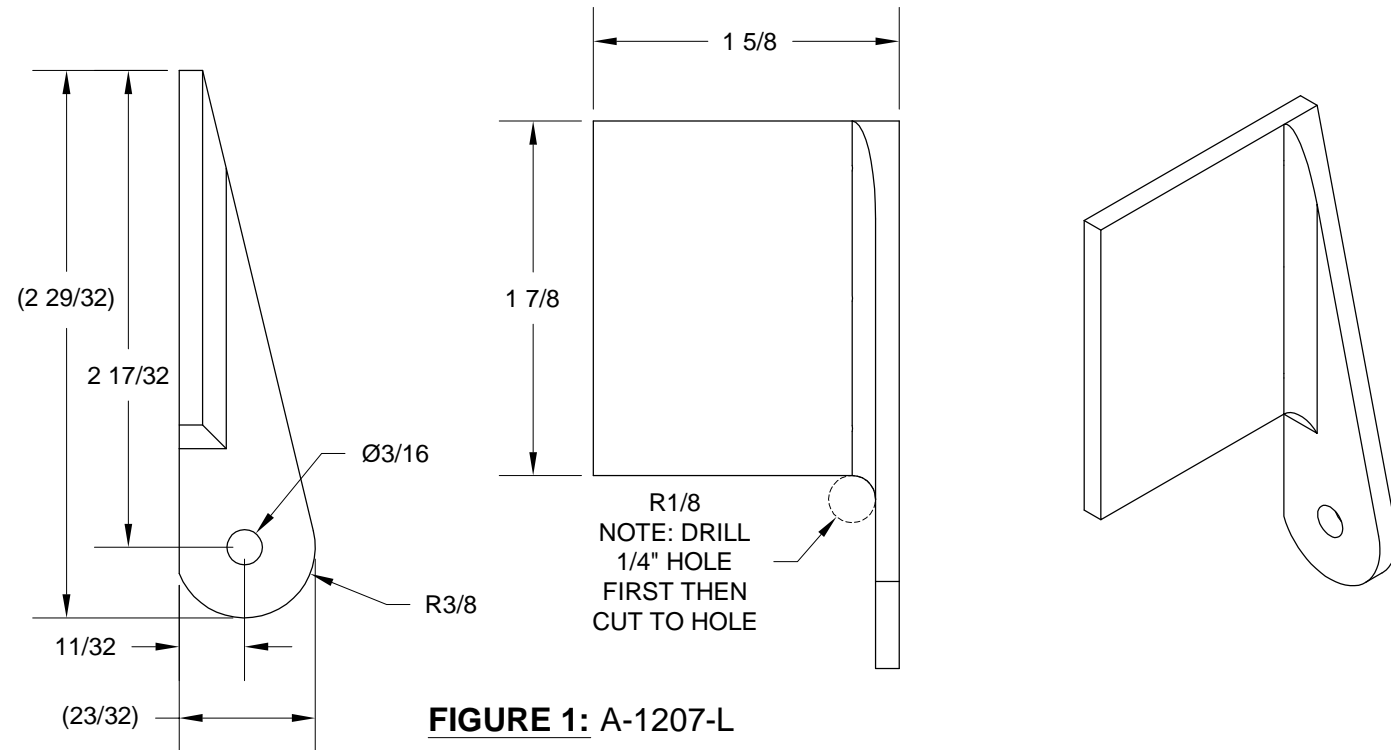

Step 2: Make four A-1206 Pivot Brackets from AEX Tie Down as shown in Figure 2.

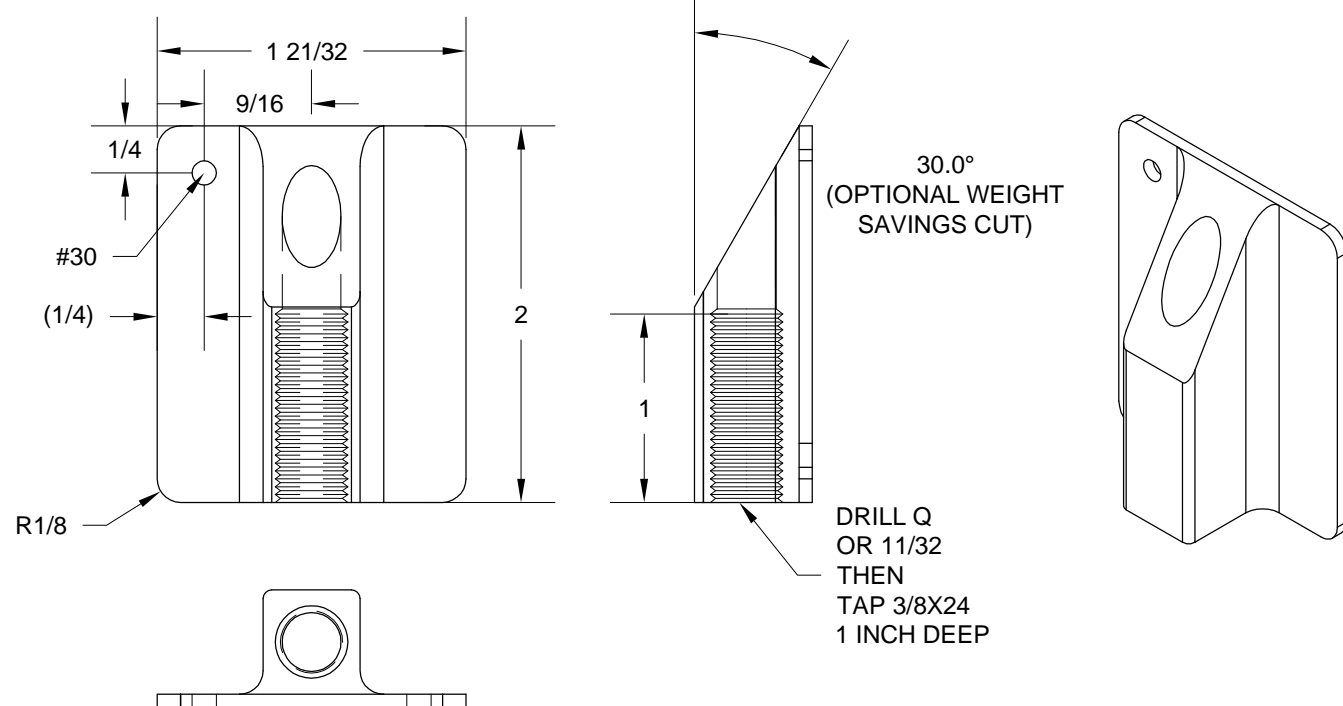

Step 3: Flute the flanges of the A-1204-L & -R Outbd Nose Ribs and A-1210-L & -R Inbd Nose Ribs at the locations shown in Figures 3 and 4.

Flute the rib flanges so as to make the rib webs as straight as possible however it is not absolutely necessary for the ribs to be perfectly straight.

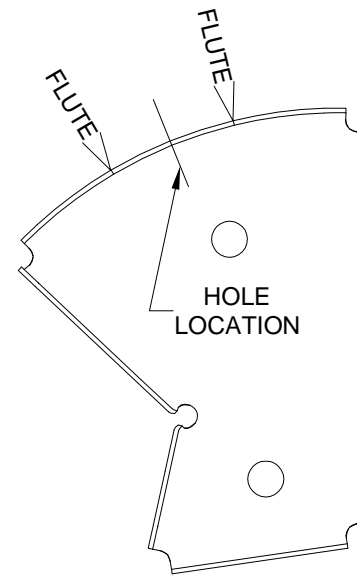

**FIGURE 3:**  
A-1204 FLUTING LOCATIONS

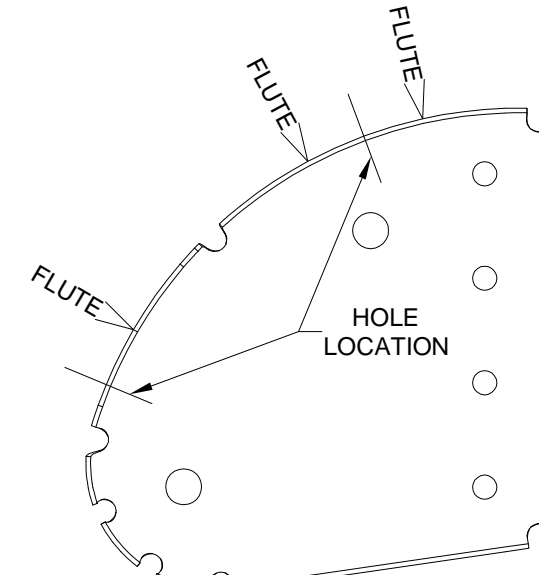

**FIGURE 4:**  
A-1210 FLUTING LOCATIONS

**NOTE:** The remainder of this section describes the assembly of the left flaperon. The right flaperon is a mirror of the left. For each step describing the assembly of the left, also complete the same operations for the right.