

REVISION DESCRIPTION:

Page: 15-03 REV 1: In Figure 4 remove depiction of rivets.
Add to rivet call-out "SHOP HEAD THIS SIDE"

Page: 15-04 REV 1: In Figure 2 add to the LP4-3, 12 PLACES callout
"MANUFACTURED HEAD INBOARD"

Page: 15-06 REV 1: In Figure 2 remove depiction of rivet shop heads installed on Page
15-03 Figure 4.
Add to LP4-3 call-out "MANUFACTURED HEAD INBOARD, 6 PLACES"

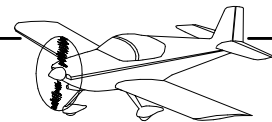

Step 1: Flute and straighten all of the W-1210 Main Rib flanges.

Step 2: Select six of the 13 W-1210-L Main Ribs and trim the fwd flange as shown in Figure 1.

Step 3: Trim the forward flange of all 13 W-1210-R Main Ribs as shown in Figure 1.

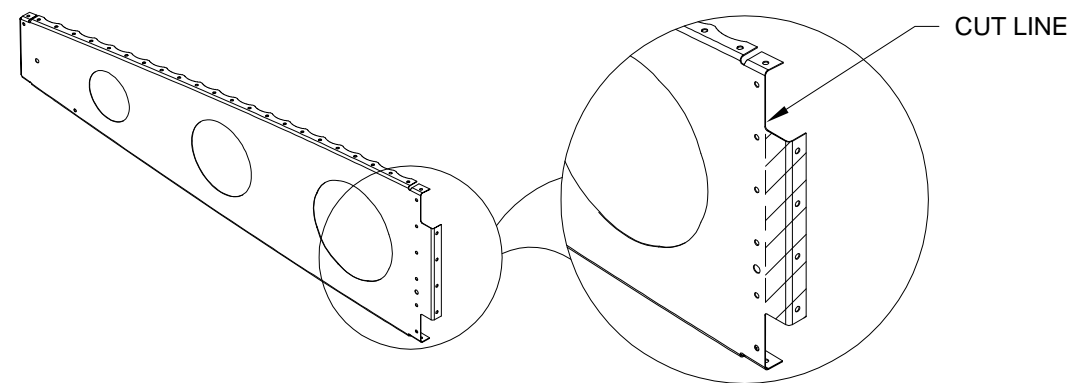

FIGURE 1: W-1210 MAIN RIB FWD FLANGE TRIM (LEFT SHOWN)

Step 4: Cleco the W-1210B-L Rib Doubler to one of the six trimmed W-1210-L Main Ribs as shown in Figure 2. Match-Drill #30 the trimmed main rib using the rib doubler as a drill guide. Uncleco the main rib and rib doubler. Deburr.

Step 5: Select one of the W-1210-R Main Ribs and cleco the W-1210B-R Doubler as shown in Figure 2. Match-Drill #30 the main rib using the rib doubler as a drill guide. Remove the clecos and rib doubler. Deburr.

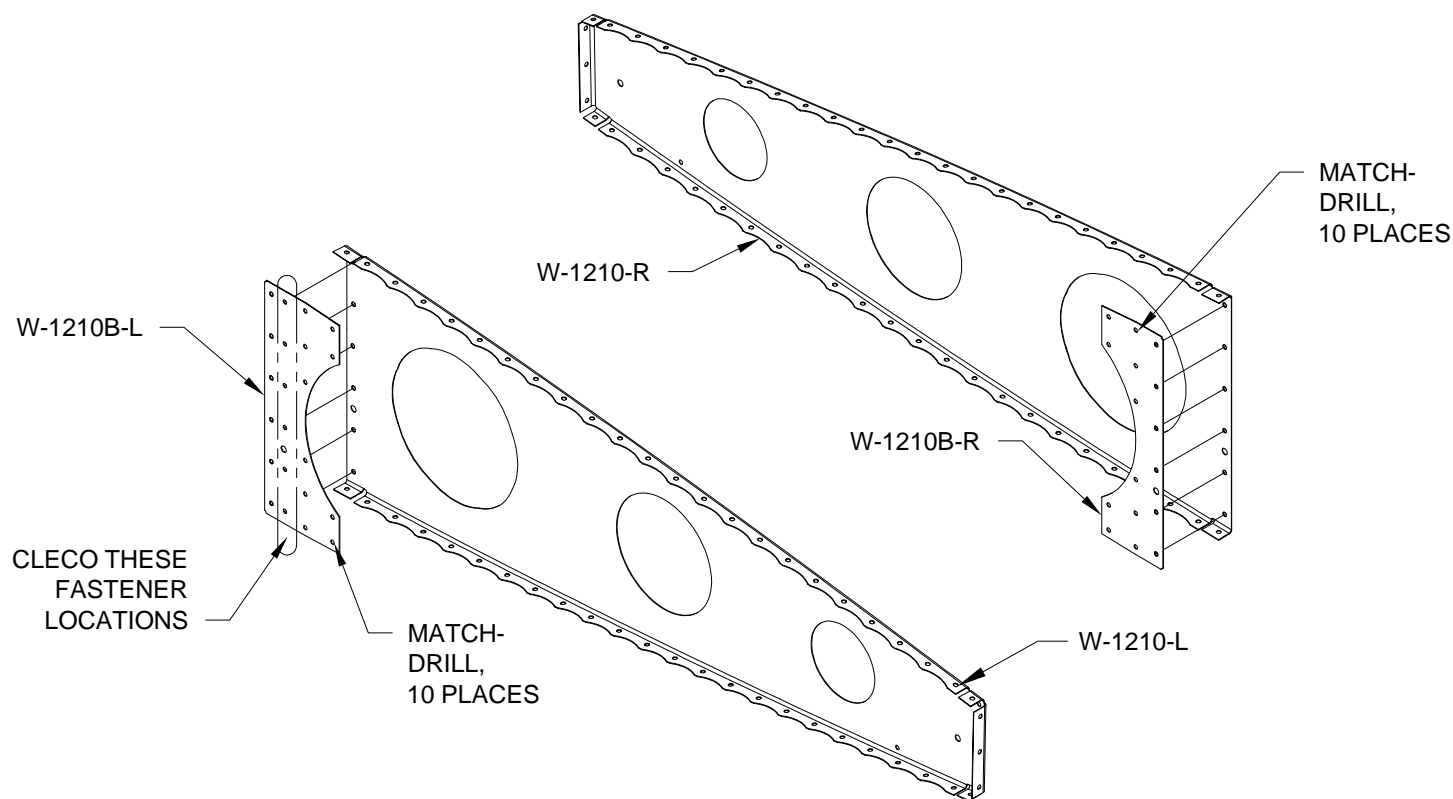

FIGURE 2: MATCH-DRILLING THE RIB DOUBLERS AND MAIN RIBS

Step 6: Select two of the W-1210-R Main Ribs and cleco one of them to the W-1216 Hinge Bracket Assembly and W-1216B-L Hinge Rib. Match-Drill #30 as shown in Figure 3. Repeat for the second main rib. Remove clecos, flaperon hinge brackets, and hinge ribs. Deburr.

Step 7: Select one of the forward flange trimmed W-1210-L Main Ribs and one of the unmodified left main ribs and cleco each to a W-1216 Hinge Bracket Assembly and W-1216B-R Hinge Rib. Match-Drill as shown in Figure 3. Remove clecos and Hinge Bracket Assemblies. Deburr.

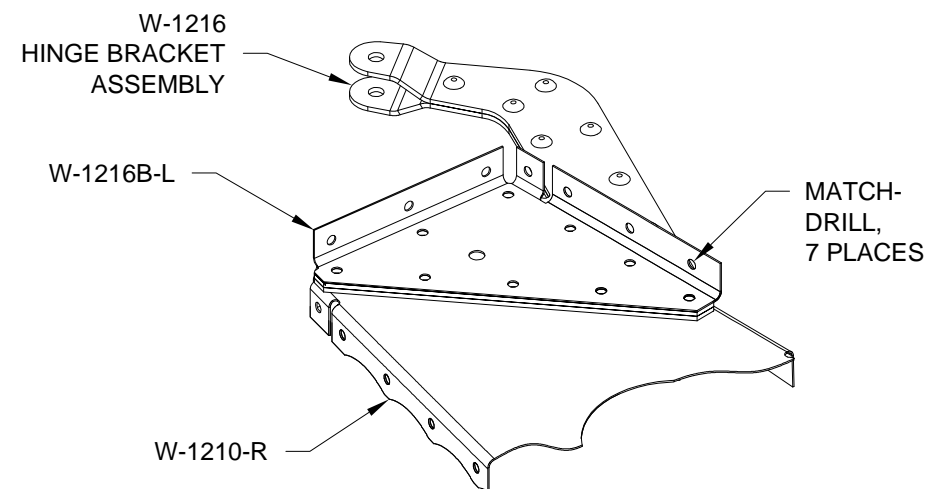

FIGURE 3: MATCH-DRILLING THE FLAPERON HINGE BRACKETS AND MAIN RIBS

NOTE: Take care not to rivet the row of holes that are needed to attach the W-1210-L and W-1210-R Main Ribs and W-1210B-L and W-1210B-R Rib Doublers to the W-1206-L and W-1206-R Spar Assemblies.

Step 8: Rivet the W-1210B-L Rib Doubler to the match-drilled W-1210-L Main Rib as shown in Figure 4.

Step 9: Rivet the W-1210B-R Rib Doubler to the match-drilled W-1210-R Main Rib as shown in Figure 4.

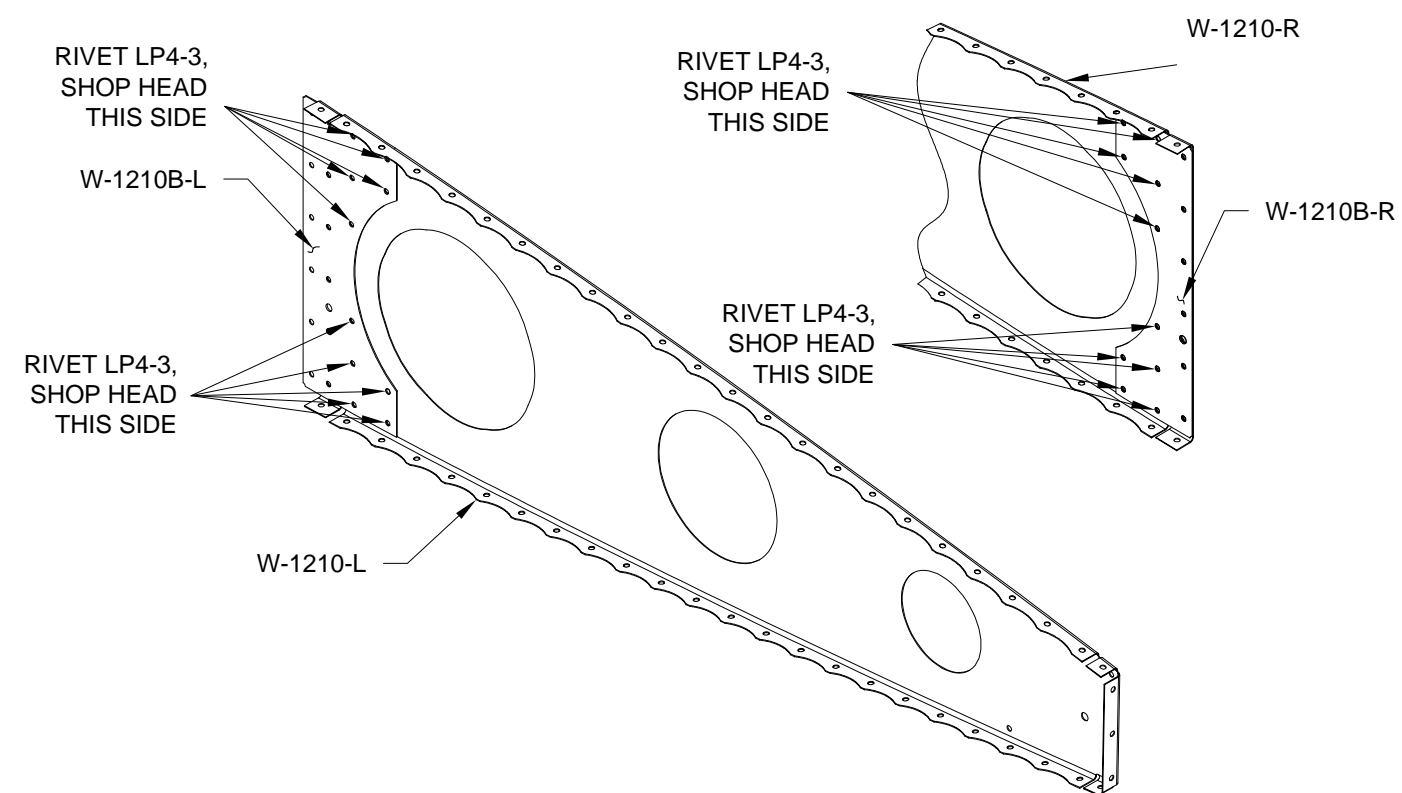

FIGURE 4: RIVETING THE RIB DOUBLERS TO THE MAIN RIBS



Step 1: Lay the W-1206-L Spar Assembly on the work surface with the flanges facing up. Select one of the W-1210-R Main Ribs and cleco then rivet to the furthest outboard attach angle on the spar assembly as shown in Figure 1.

Step 2: Take one W-1210-R Main Rib which was match-drilled to the W-1216B-L Hinge Rib and cleco then rivet to the next inboard attach angle on the W-1206-L Spar Assembly as shown in Figure 1.

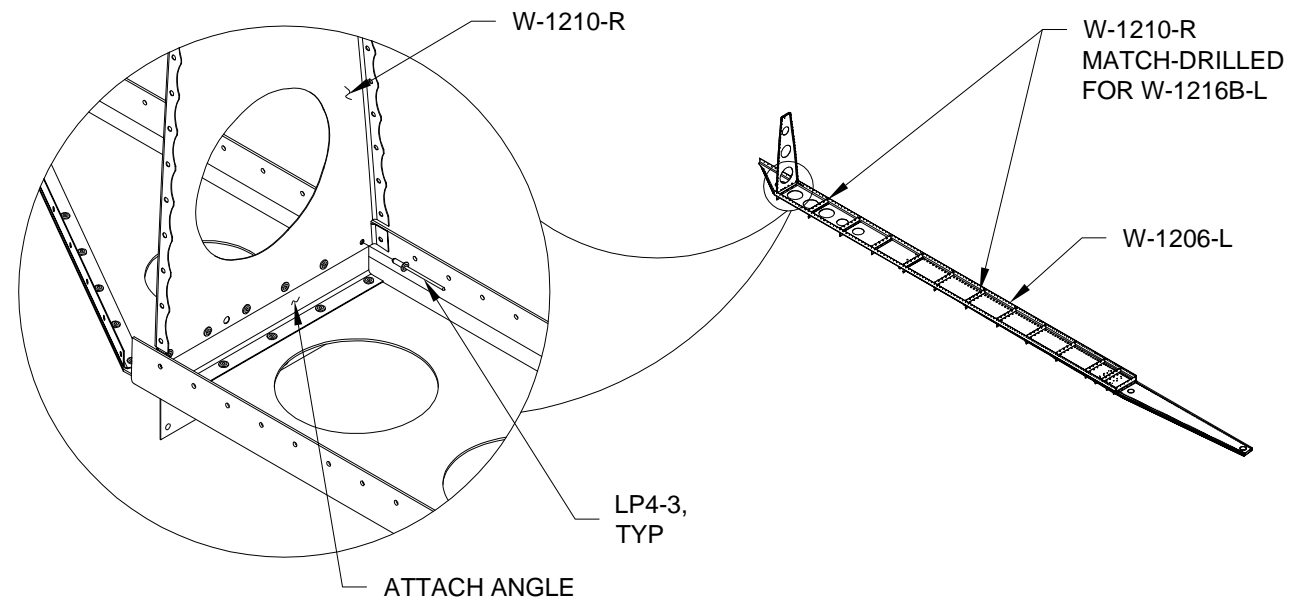

FIGURE 1: ATTACHING THE MAIN RIBS

Step 3: Select four more of the W-1210-R Main Ribs and cleco then rivet to the next inboard attach angles on the W-1206-L Spar Assembly.

Step 4: Cleco then rivet the remaining W-1210-R Main Rib which was match-drilled to the W-1216B-L Hinge Rib to the next inboard attach angle on the W-1206-L Spar Assembly as shown Figure 1.

Step 5: Select five more of the W-1210-R Main Ribs and cleco then rivet to the next inboard attach angles on the W-1206-L Spar Assembly.

Step 6: Cleco then rivet the W-1210-L Main Rib with the attached W-1210B-L Rib Doubler to the remaining attach angle on the W-1206-L Spar Assembly. See Figure 2.

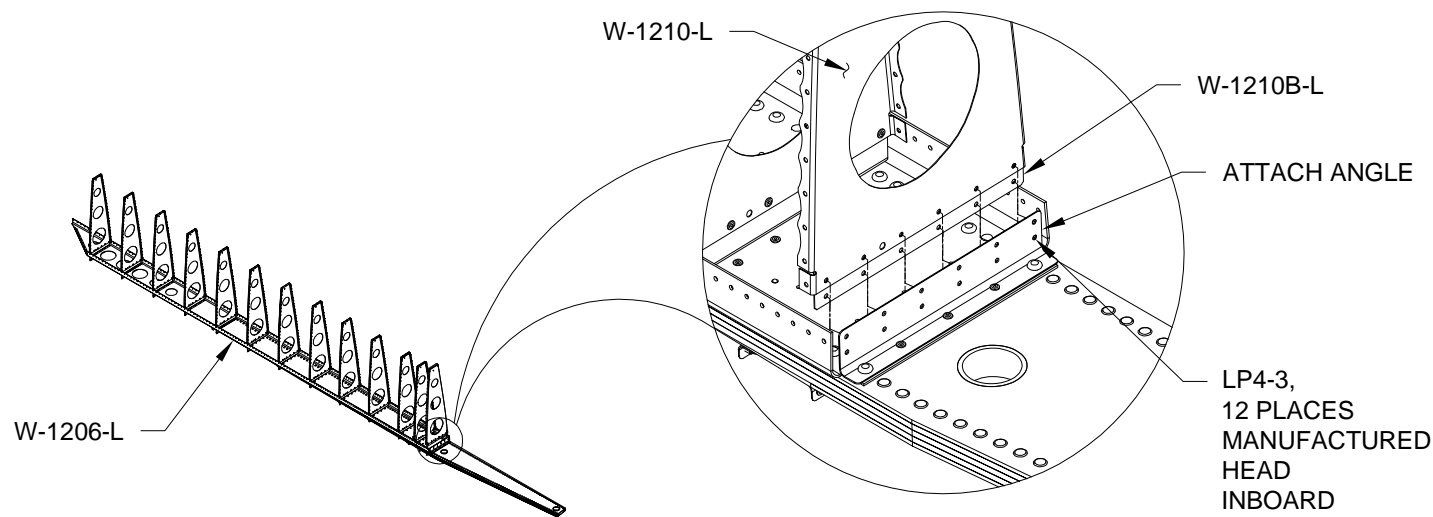

FIGURE 2: ATTACHING THE MAIN RIB AND DOUBLER

Step 7: Cleco the Left Rear Spar Assembly to the aft flanges of the W-1210 Main Ribs as shown in Figure 3.

Step 8: Match-drill #30 the hole locations in the aft flange of the main rib as shown in Figure 3. Remove the clecos and the Left Rear Spar Assembly and deburr match-drilled holes as required.

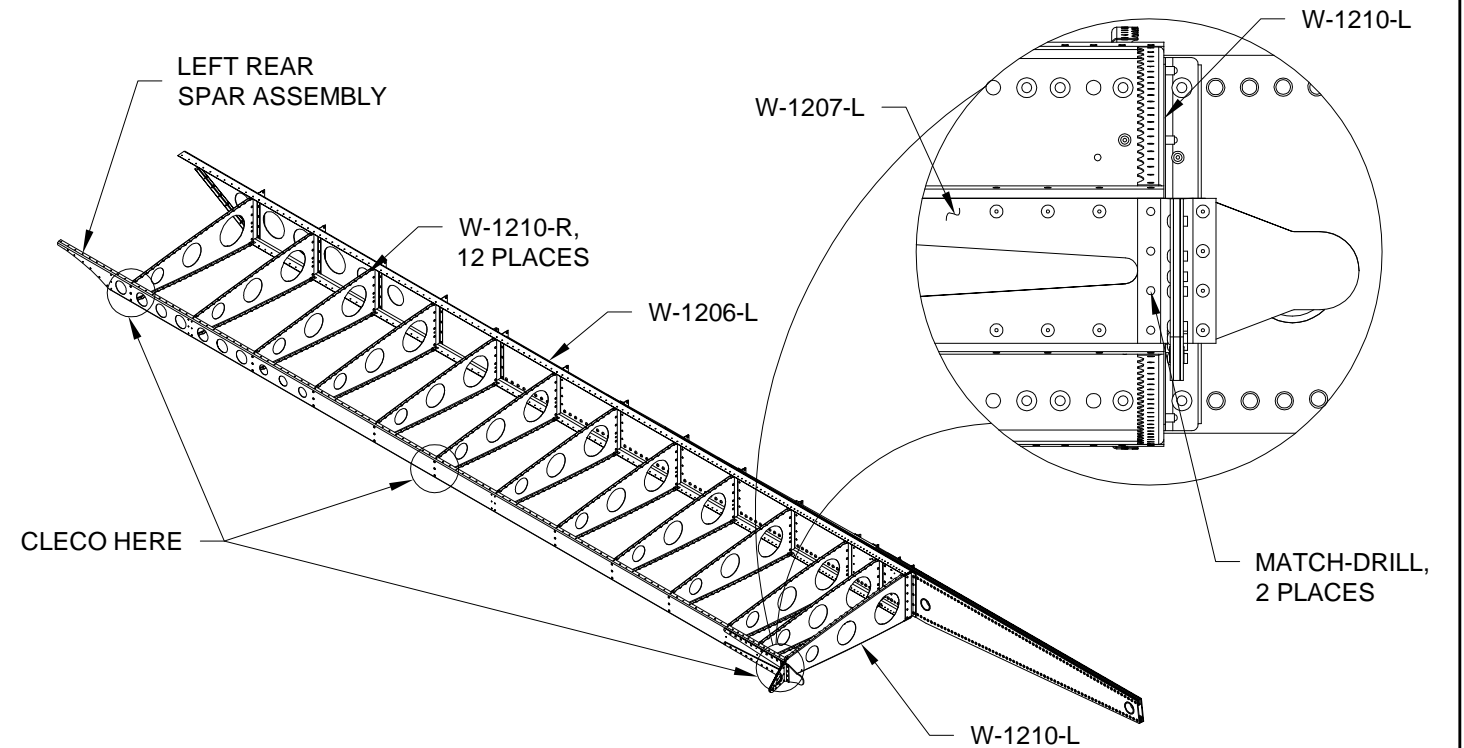

FIGURE 3: MATCH-DRILLING MAIN RIB AFT FLANGE

Step 9: Cleco then rivet the Left Rear Spar Assembly to the aft flanges of the W-1210 Main Ribs as shown in Figure 4.

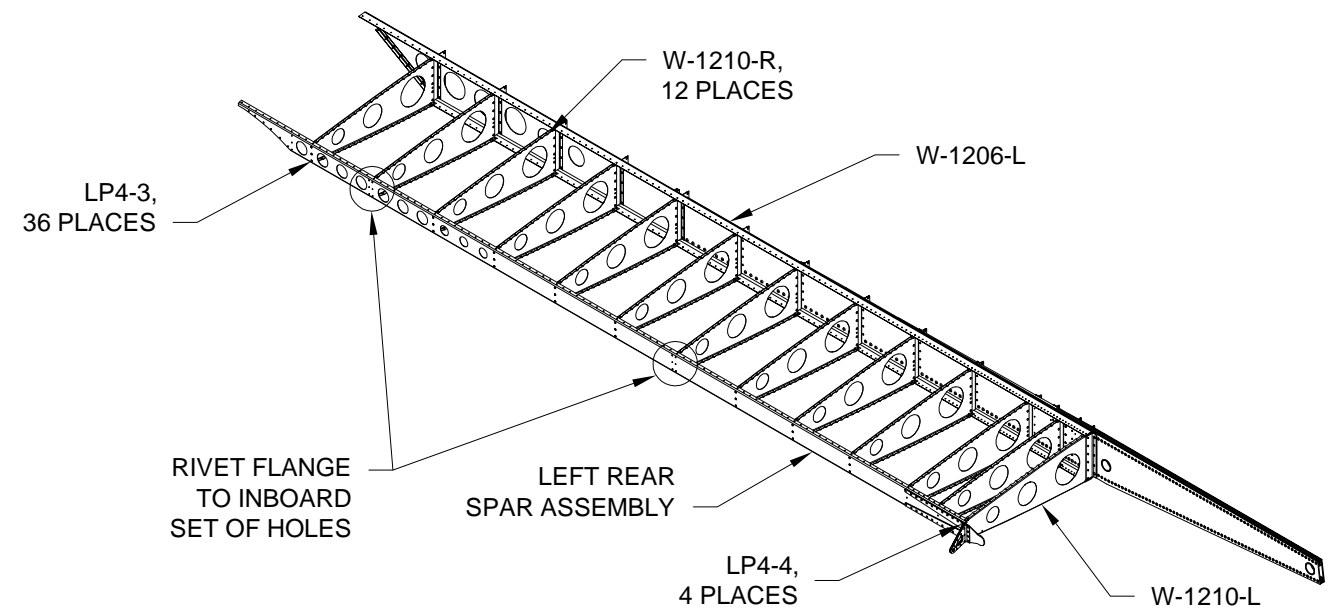

FIGURE 4: ATTACHING THE REAR SPAR



Step 1: Lay the W-1206-R Spar Assembly on the work surface with the flange facing up. Select one of the forward trimmed W-1210-L Main Ribs and cleco then rivet to the furthest outboard attach angle on the spar assembly as shown in Figure 1.

Step 2: Cleco then rivet the forward trimmed W-1210-L Main Rib which was match-drilled to the W-1216B-R Hinge Rib to the next inboard attach angle on the W-1206-R Spar Assembly as shown in Figure 1.

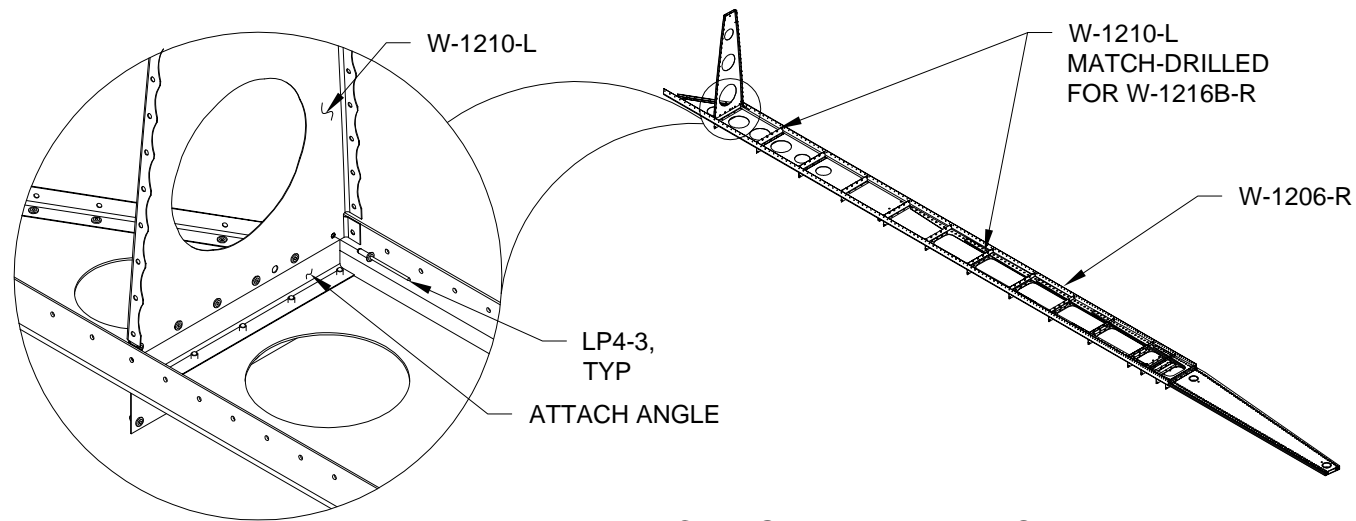

FIGURE 1: ATTACHING THE MAIN RIBS

Step 3: Select three of the forward trimmed W-1210-L Main Ribs and cleco then rivet to the next inboard attach angles on the W-1206-R Spar Assembly.

Step 4: Select one unmodified W-1210-L Main Rib and cleco then rivet to the next inboard attach angle and to the W-1206-L Spar Assembly.

Step 5: Cleco then rivet the W-1210-L Main Rib which was match-drilled to the W-1216B-R to the next inboard attach angle and to the W-1206-R Spar Assembly.

Step 6: Cleco then rivet the remaining five W-1210-L Main Ribs to the next inboard attach angles and to the W-1206-R Spar Assembly as shown in Figure 2.

Step 7: Cleco then rivet the forward trimmed W-1210-R Main Rib with the attached W-1210B-R Rib Doubler to the most inboard attach angle on the W-1206-R Spar Assembly as shown in Figure 2.

NOTE: Use LP4-3 for attaching W-1210 Main Ribs to spar attachment angles. Use LP4-4 for attaching W-1210 Main Ribs to W-1206-R Main Spar Assembly.

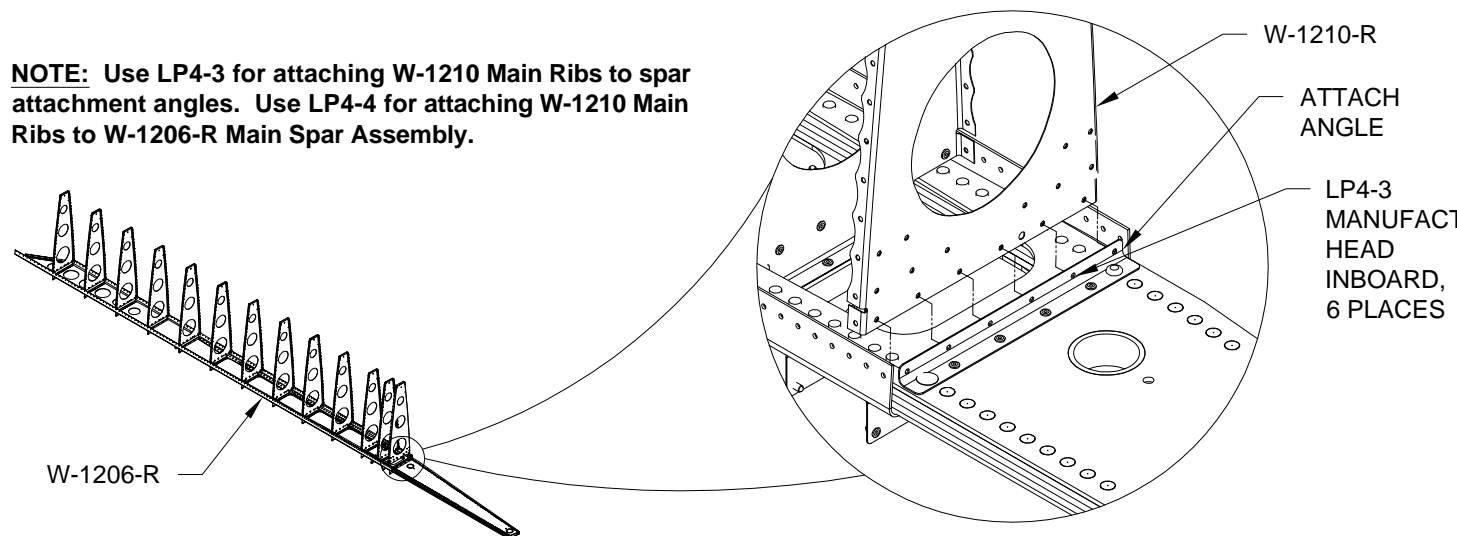

FIGURE 2: ATTACHING THE MAIN RIB AND DOUBLER

Step 8: Cleco the Right Rear Spar Assembly to the aft flanges of the W-1210 Main Ribs as shown in Figure 3.

Step 9: Match-drill #30 the hole locations in the aft flange of the main rib as shown in Figure 3. Remove clecos and Rear Spar Assembly and deburr match-drilled holes as required.

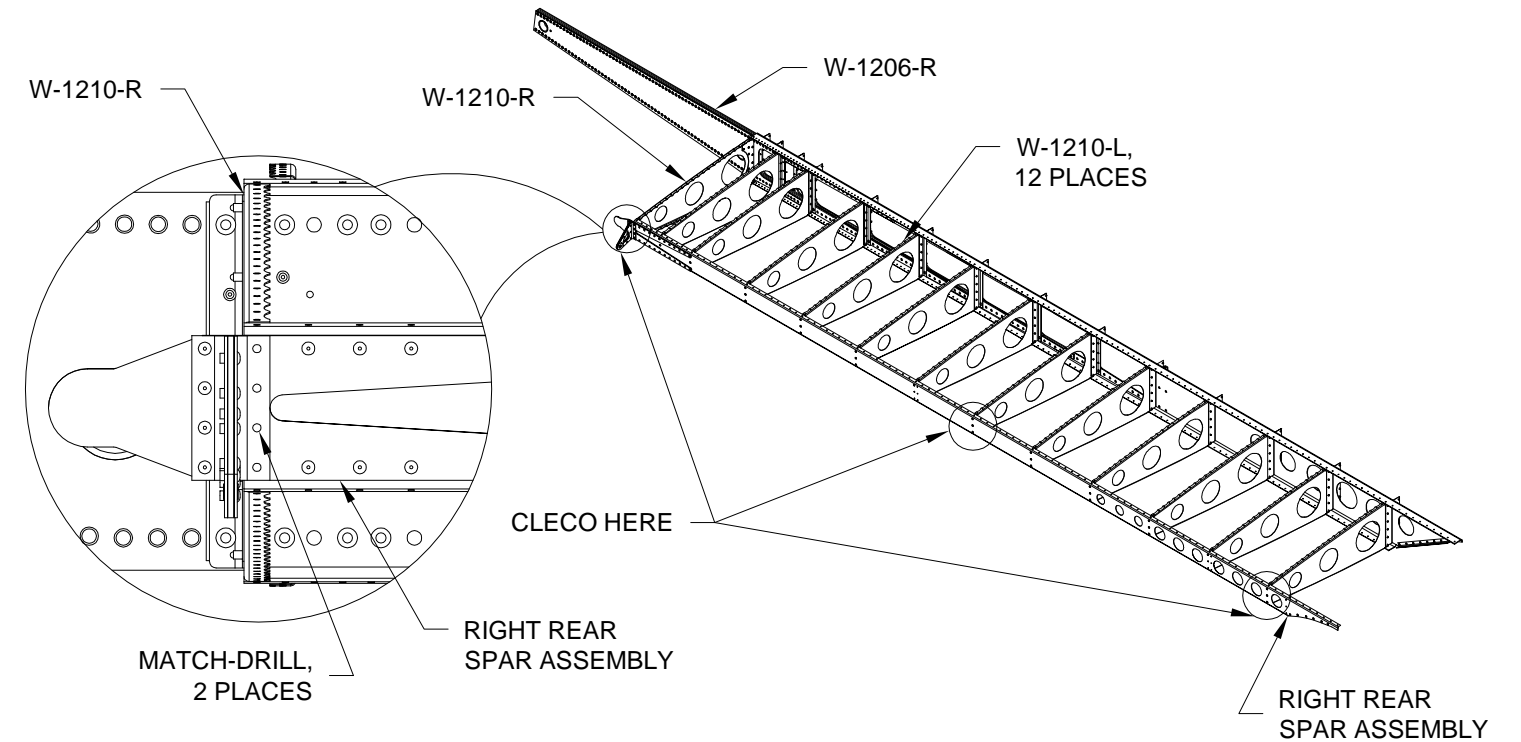

FIGURE 3: MATCH-DRILLING MAIN RIB AFT FLANGE

Step 10: Take the Right Rear Spar Assembly and cleco then rivet to the aft flanges of the W-1210 Main Ribs as shown in Figure 4.

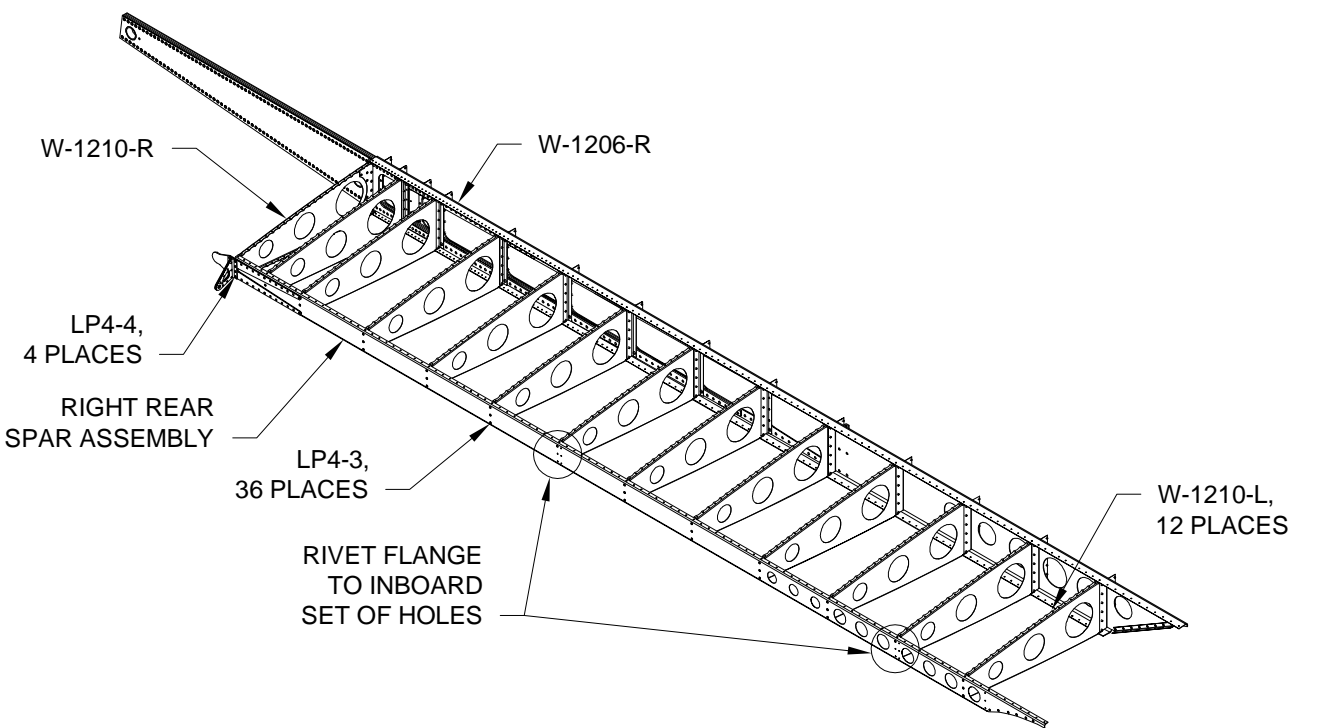

FIGURE 4: ATTACHING THE REAR SPAR