



Step 1: Remove the material from the VS-1204 Fwd Skin, called out in Figure 1.

Step 2: Remove the material from the VS-1201 Main Skin, called out in Figure 2, Detail A.

Step 3: Final-drill #19, the nutplate screw holes in the VS-1204 Fwd Skin per call-out in Figure 1.

Step 4: Final-drill #19, the nutplate screw holes in the VS-1201 Main Skin per call-out in Figure 2, Detail B.

Deburr all of the final-drilled holes from Steps 3 and 4.

Step 5: Dimple the #19 holes in the VS-1204 Fwd Skin using a #8 dimple die as called out in Figure 1.

Step 6: Dimple the #19 holes in the VS-1201 Main Skin using a #8 dimple die as called out in Figure 2, Detail B.

Step 7: Dimple the nutplate attach rivet holes in the VS-1201 Main Skin using a 3/32 dimple die as called out in Figure 2, Detail B.

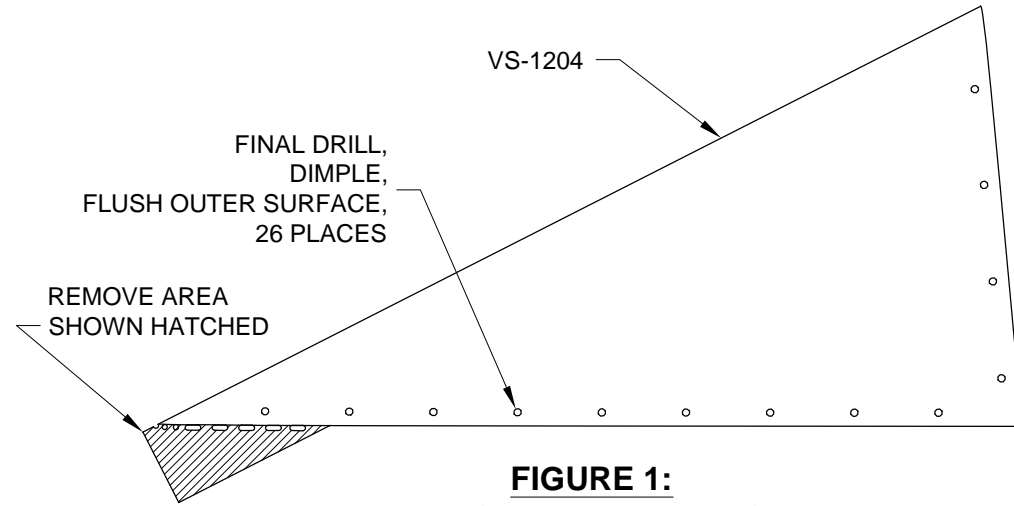

FIGURE 1:
FWD SKIN PREPARATION

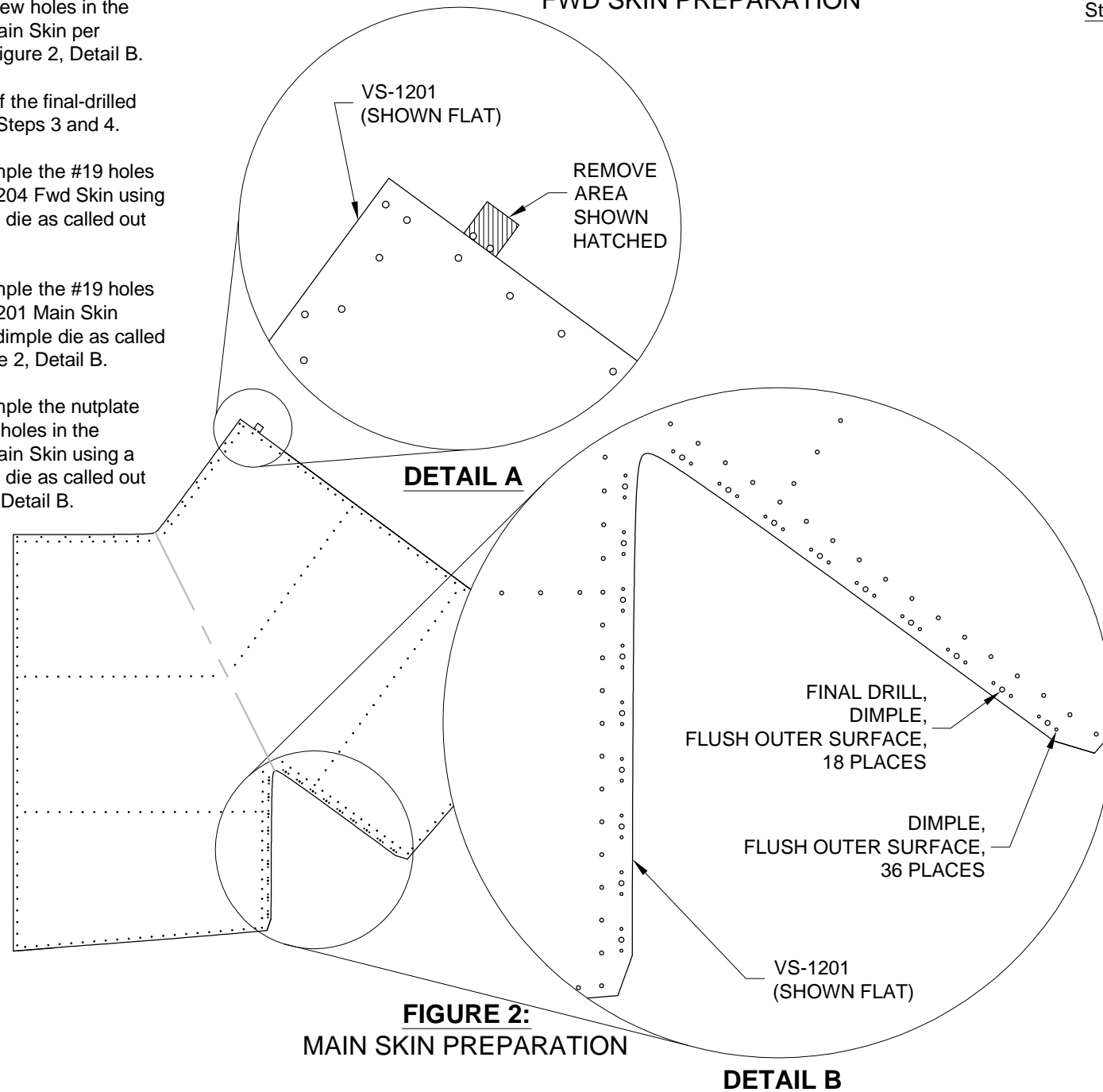

FIGURE 2:
MAIN SKIN PREPARATION

DETAIL B

NOTE: A small diameter female die is required to dimple the nutplate attach rivet holes on a countersunk nutplate. An alternative would be grinding material from a standard female die to clear the recess of the nutplate.

Step 8: Dimple the nutplate attach rivet holes using a 3/32 dimple die as called out in Figure 3.

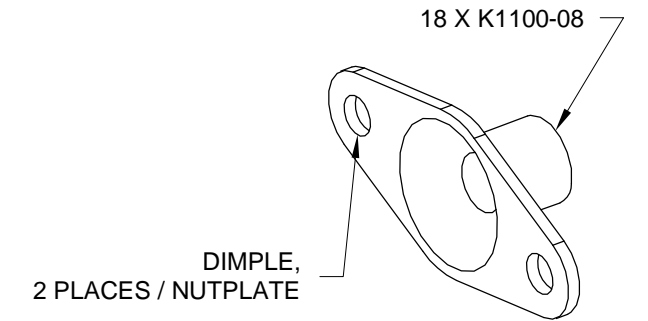

FIGURE 3:
NUTPLATE PREPARATION

Step 9: Rivet the previously dimpled K1100-08 Nutplates, to the VS-1201 Main Skin per call-outs in Figure 4.

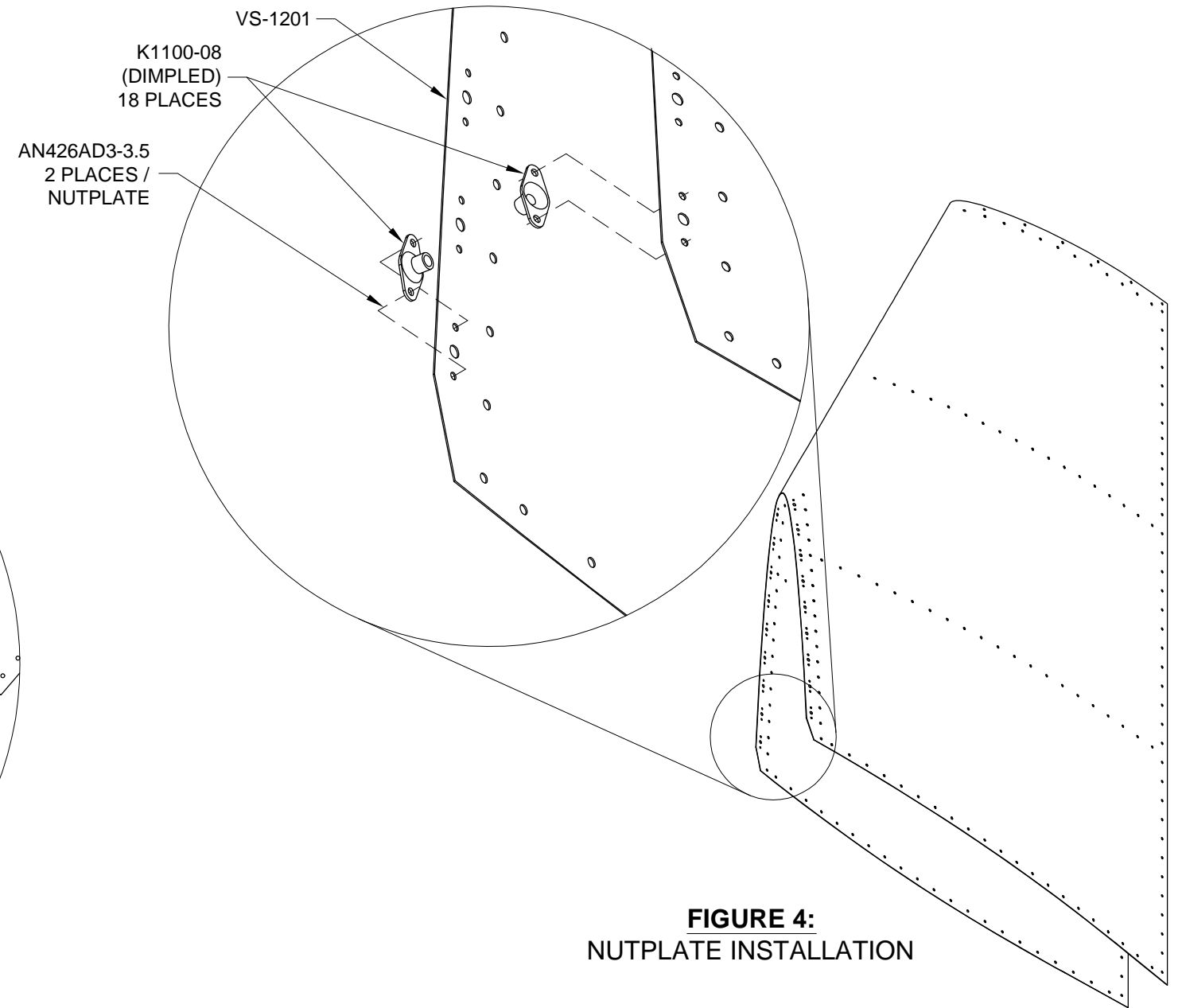

FIGURE 4:
NUTPLATE INSTALLATION